

Mobile ad hoc network integrated wireless networks: a survey

Dr. S. SivaNageswara Rao ^{1*}, OrchuAruna ¹, Dr. K. Lakshminadh ¹

¹Narasaraopeta Engineering College, Guntur
*Corresponding author E-mail: drssnr@yahoo.in

Abstract

Now a day, every one using mobile devices for communicating with others. The development of new technologies, like Internet of Things (IoT) needs coverage, connectivity, scalability and QoS. In ubiquity networks, the major issues are coverage, connectivity, scalability and QoS. To solve these limitations, integrating wireless networks with ad hoc networks. This paper provides detail survey on how ad hoc networks are integrated with Cellular Network, Wireless Mesh Networks and Wireless Sensor Networks. This integration may resolve the problems of coverage, connectivity, scalability and QoS.

Keywords: Cellular Networks; Wireless Mesh Networks; Wireless Sensor Networks; IoT.

1. Introduction

Mobile Ad hoc Network (MANET) is a collection of mobile nodes forming an autonomous network without having any infrastructure. In MANET, each node acts as an Access Point or Relaying Node or Gateway to forward data to other nodes [1].

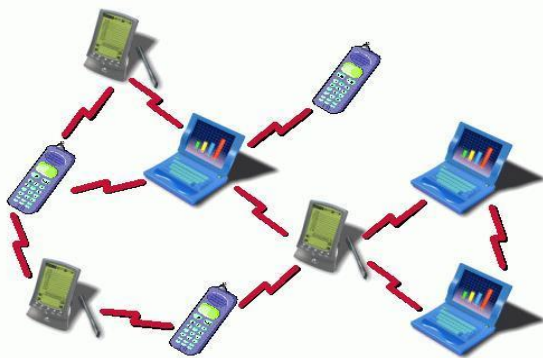

Fig. 1: Mobile Ad Hoc Networks.

1.1. MANET: characteristics

The important characteristics of MANETs are: decentralized control, lack of cooperation among MHs, high speed mobility of MHs, dynamic network topology, scalability, limited availability of resources, such as battery constraints and bandwidth constraints. Some of the characteristics are explained as follows [4,5].

Dynamic Topology: In MANET, mobile Hosts (MHs) are moving from one place to another place autonomously. So, MHs mobility creates dynamic topologies [2].

Bandwidth: Mobile ad hoc networks are having short wireless transmission power and also having low capacity compared to fixed networks. This can be happened because of interference, fading and multiple accesses [3].

Battery Power: The MHs are having limited size batteries. So, energy constraints are considered.

Decentralized Control: In MANETs, communication depends upon cooperation of neighbour nodes. Due to unreliable links, communication from one host to another host required centralized authority becoming a challenging issue.

Scalability: Due to dynamic topologies, scalability is a challenging issue to maintain a large network consisting of more number of MHs. This can be happened because of limited processing and memory capabilities of MHs.

MANETs can be used in various areas, Military operations, Search and Rescue operations, Disaster Management, Law Enforcement and Commercial Use, etc. The limitations of MANETs are limited connectivity, power constraints and quality of service (QoS). To overcome these limitations, various other wireless networks are going to be integrated with MANETs. This integration leads to form a new network, called heterogeneous network [6].

2. Need of integration

The manufacturing process and the cost of production have increased for portable hand-held devices since last some years. The portable hand-held devices like cellular phones, laptops, tablet PCs, etc. These devices are used to communicate the user use in different ways [7]. Depends upon the usage of wireless communication, portable devices are need to provide digital services to the user, like digital TV, video conference, etc. However, the usage of all these digital services can be addressed some issues. The user transmitting data or services to different broadcasters that can be located in different networks [9]. It gets more complicated, when the user transmits data or services to different broadcasters with the help of these portable devices in homogeneous network. To solve these types of problems, need a new network that is called heterogeneous network. To integrate different types of wireless networks, to form a heterogeneous network. It manages and controls traffic load and QoS effectively [8].

3. Integration of MANET with cellular networks

In world, every one using mobile device for communicating with others. For that purpose, the development of a new technology needs support of Mobile Cellular Network (MCN). In wireless networks, the major issues are coverage and connectivity. To solve these problems, integrating Cellular Network with adhoc networks (MANETs) [10].

In Cellular Networks, mobile hosts are attached to nearby BTS using single hop relaying mechanism. Due to the integration of Cellular Network with MANETs, the mobile hosts in MANET connected to the compatible BTS in Cellular Network. When the Cellular Network connection needed Multi-hop Relaying mechanism, in those situations a MANETs established connection between those nodes. This integration improves the performance of Cellular Network. In this integration mobile hosts can transfers the data using either single hop or multi hop mechanisms.

Integrated Cellular and Ad hoc Relaying System and Mobile Assisted Data Forwarding are some of example architectures that shows the integration of MANETs with Cellular Networks.

3.1. iCAR

iCAR is a new heterogeneous network architecture, which is based on the integration of cellular network with mobile ad hoc network. The major purposes of these heterogeneous networks are used to reduce the congestion which can be heavier in cellular networks due to unbalanced traffic. This iCAR mechanism balance the unbalanced traffic loads between cells by using Ad hoc Relaying System (ARS) to divert traffic from one congested cell to other non-congested cell.

In a Cellular Network System, A Mobile Host can be accessed data channels of BTS; those are located in the same cell. There is no possibility to access data channels of other cells. So, the cell may be congested while other cells are still having free data channels. To mitigate the congestion problem by allocating the data channels dynamically, using iCAR with the help of ARSs, to bypass traffic from one congested cell to other non-congested cell. Here ARSs and MHs have two interfaces, Cellular Interface and Relaying Interface. In ARS, Cellular Interface is used to communicate with BTSs and Relaying Interface is used to communicate with either Mobile Hosts or another ARSs. In Mobile Host, Cellular Interface is used to communicate with BTSs and Relaying Interface is used to communicate with ARSs

There are three basic relaying strategies.

- 1) **Primary Relaying:** In cellular networks, from congested cell, the mobile host involved in a new call will be blocked. But in iCAR mechanism, the mobile host of congested cell communicating with the BTS of other non-congested cell through ARSs. For Example in Figure 2, Cell X is a congested cell whereas cell Y is a non-congested cell .MH1 in cell X communicates with the BTS of cell Y (non-congested) through two ARSs. This Relaying mechanism diverts the traffic from congested cell X to non-congested cell Y.

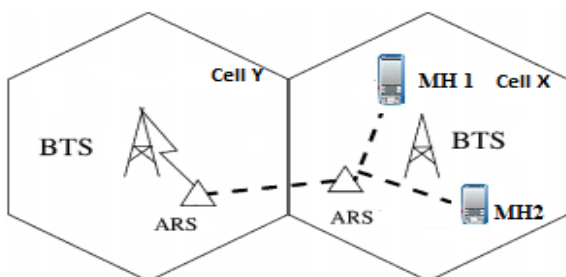

Fig. 2: Primary Relaying.

- 2) **Secondary Relaying:** When the primary relaying is not possible, in such cases using secondary relaying. In secondary relaying, two cases are possible to solve the congestion problem. For example in Figure 3(a), the mobile host MH2 is present Cell Y (congested), communicates with Cell X BTS (non-congested) through ARS. That means it is presented in Cell Y (congested), but accessed data channels from Cell X (non-congested) through Relaying interface (ARS). The mobile host MH1 is currently involved in a new call; it can access data channels used by MH2. In Figure 3(b), to establish a relaying route between MH1 and its corresponding mobile host that is either MH2 or MH3, depending on whether MH1 is involved in intracellular or inter cellular call.

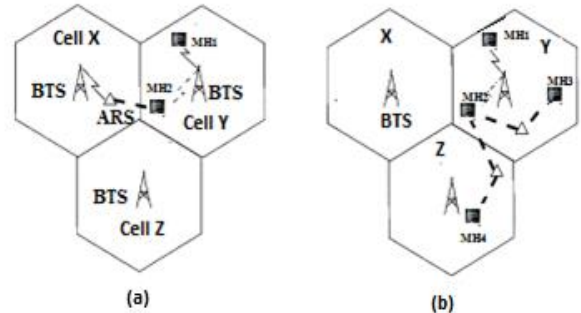

Fig. 3: Secondary Relaying.

- 3) **Cascaded Relaying:** When the primary relaying or secondary relaying failed to relay data from congested cell, using cascaded relaying. It combines both primary relaying and secondary relaying to relay data through ARSs, as shown in Figure 4, one may apply any of the two basic secondary relaying strategies described above in the congested cell R to establish a relaying route between an MH in cell R and either another base station in a non-congested cell. In this way, ARS of cell R can be allocated the data channels previously used by MH 4 in cell R, and, in turn, MH1 can be allocated the data channels previously used by MH 2 in cell Q if the route between MH1 and ARS of cell Q is set up by secondary relaying.

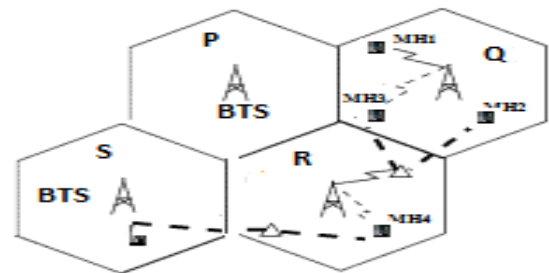

Fig. 4: Cascaded Relaying.

3.2. MADF

Mobile Assisted Data Forwarding [2] was mainly developed for balancing load between Base Stations. It is used to sharing the traffic between one BTS (which is highly loaded) to another BTS (which is free).In MADF, we add forwarding channels, used to connect mobile hosts in an overloaded cell and its surrounding free cells without going through the overloaded cell's Base Stations and also added ad hoc overlay to the fixed network. The MADF balancing the load between two BTSs through forwarding channels. The forwarding channel is not a base station, only used for relaying data from one cell to another cell. It may be a mobile

node in a cell or a fixed repeater. We illustrate in the following Figure 5.

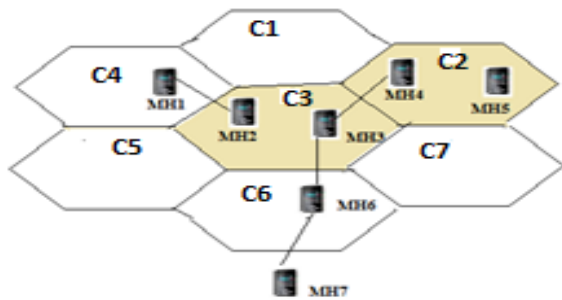

Fig. 5: Mobile Assisted Data Forwarding.

In Figure 5, Cell C2 and Cell C3 are overloaded cells, relaying data from cell C2 and cell C3 takes more time. MH1, MH3 and MH4 are forwarding channels. It takes two hops for the packet from MH2 to be absorbed by a Base Station. On the other hand, since MH4 cannot find an immediate forwarding channel in its neighbouring free cell, it takes three hops for its data to be absorbed by a Base Station. For the Mobile Hosts out of the coverage of this wireless network (such as MH7), they can accordingly forward their packets to a channel (such as MH6) in order to stay connected to the network. Note that a forwarding channel may serve multiple users at the same time. In MADF, power control may be required in order to reduce the co-channel interference of the forwarding channel.

4. Integration of MANET with wireless mesh networks

Wireless Mesh Networks are fully connected semi-ad hoc network having static wireless backbone. WMNs are self-organized, self-healing, self-balancing networks. In addition to providing the network connectivity among the nodes in a mesh topologies for sharing localized information through mesh elements. In the globalization scenario, there is a need of sharing the data among various wireless mesh networks to other networks.

4.1. WMNs: characteristics

Wireless Mesh Networks supports semi-ad hoc networking and capable of self-organization, network access, node mobility, power consumption, compatibility and interoperability.



Fig. 6: Integration of MANET-WMN.

Based on the above characteristics, MANETs are generally considered as a subset of WMNs. WMN is semi-infrastructure network whereas MANET is an unstructured network. The properties of these two networks are somewhat similar. So, MANET is integrated with WMN is possible to form a different homogeneous network. Because of the above characteristics, mobile node of a MANET is integrated with compatible mesh router of WMN. This integration enables the sharing information from MANET to WMN and vice versa.

5. Integration of MANET with wireless sensor networks

Wireless Sensor Network is a wireless network, which contains spatially distributed autonomous components using sensors to monitor the physical and environmental conditions. WSN contains Base Stations (BS) and number of sensor nodes. WSNs incorporate gateway that provides wireless connectivity back to the wired and decentralizing nodes. WSNs are data centric networks. In WSNs, data is forwarded through gateway. Gateway is allowed to connect the other wired or wireless networks. The applications of WSNs and MANETs are similar, those are used in rescue operations, disaster management, etc. to extend the availability of networking connectivity, there is a need to integrate the WSNs with MANET to resolve the various problems like bandwidth, energy and deliver time.

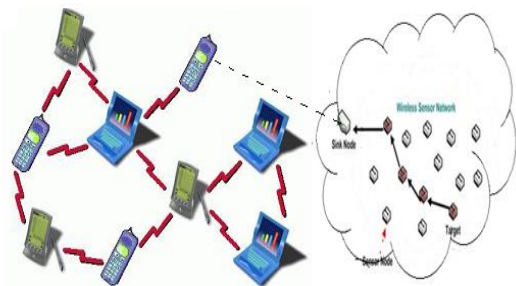

Fig. 7: Integration of MANET-WSN.

MANETs and WSNs both are unstructured networks. The properties of these two networks are somewhat similar. So, MANET is integrated with WSNs is possible to form a different heterogeneous network. Because of similar characteristics in both MANET and WSN, integrating the mobile node of MANET with sink node of WSN. This integration enables the sharing information from MANET to WSN and vice versa.

6. Applications of integrated heterogeneous networks

The Applications of Integrated Heterogeneous Networks are Health Management, Smart Homes, Measure the Water Levels, Smart Cities, Measure the Temperature, Smart Grids and Industrial Internet.

7. Conclusion

MANET is an unstructured, self-organized, autonomous network. Various integration mechanisms are studied in this survey, which provides complete picture of cellular network, wireless mesh network and wireless sensor network incorporation of MANETs. The incorporation of MANETs with other networks delivers the QoS. Such integration mechanism can help in efficient data transmission, reduces energy wastage and connectivity with limited cost.

References

- [1] Wu H, Qiao C, De S, Tonguz O. Integrated Cellular and Ad hoc Relaying Systems - iCAR. *IEEE Journal on Selected Areas in Communications*. 2001 Oct; 19(10):2105-15. <https://doi.org/10.1109/49.957326>.
- [2] Wu X, Chan SHG, Mukharge B, Bhargava B. MADF-Mobile Assisted Data forwarding for wireless Data Network. *Journal of Communication and Network*. 2004 Sep; 6(3):216-25. <https://doi.org/10.1109/JCN.2004.6596578>.
- [3] Ian F. Akyildiz, Xudong Wang, Weilin Wang, 'Wireless Mesh Networks: A Survey', *Computer Networks* 47 (2005), Elsevier.

- [4] Wu F, Kao YF, Tseng YC. Wireless Sensor Networks towards cyber physical systems. *Pervasive and Mobile Computing*. 2011 Aug; 7(4):397–413. <https://doi.org/10.1016/j.pmcj.2011.03.003>.
- [5] Rajesh, M., and J. M. Gnanasekar. "Path Observation Based Physical Routing Protocol for Wireless Ad Hoc Networks." *Wireless Personal Communications* 97, no. 1: 1267-1289. (2017)
- [6] Cavalcanti D, Agarwal D, Cordeiro C, Xie B, Kumar A. Issues in Integrating Cellular Networks, WLANS and MANETs: A futuristic heterogeneous wireless network. *IEEE Wireless Communications*. 2005 Jun; 12(3):30–41. <https://doi.org/10.1109/MWC.2005.1452852>.
- [7] Nguyen-Vuong QT. Mobility management in 4G Wireless heterogeneous networks. University of Évry-Val d'Essonne, l'ENSIIE. 2008.
- [8] Kent S, Seo K. Security architecture for the internet protocol. RFC 4301. Network Working Group, 2005. Modified in 2015.
- [9] I.F. Akyildiz, W. Su, Y. Sankarasubramaniam, E. Cayirci, Wireless sensor networks: a survey, *Computer Networks* 38 (4) (2002) 393–422. [https://doi.org/10.1016/S1389-1286\(01\)00302-4](https://doi.org/10.1016/S1389-1286(01)00302-4).
- [10] I.F. Akyildiz, I.H. Kasimoglu, Wireless sensor and actornetworks: research challenges, *Ad Hoc Networks* 2 (2004)351–367. <https://doi.org/10.1016/j.adhoc.2004.04.003>.