

Comparative study of energy efficient MAC protocol with channel aware packet Scheduling in MANET

T. Dheepak^{1*}, S. Neduncheliyan²

¹ Research Scholar, Department of Computer Science, Research & Development Centre, Bharathiar University-Coimbatore, Tamil Nadu, India

² Principal, Jaya College of Engineering & Technology, Chennai, Tamilnadu, India.

*Corresponding author E-mail: dheepak.me@gamil.com

Abstract

Mobile Ad Hoc Network is the centralized communication system which is used for transferring information through a secured mode from one end to another end. However, there is an energy loss that has been noticed in MANET. In this work, an efficient energy based Link Failure State Neighbor Detection Effective Efficient Protocol (LFSNDEEP) is to enhance the energy efficiency of the mobile node, and optimal transmission ratio computes Data, Audio, and Video packets. The proposed research on LFSNDEEP protocol is compared to Effective Efficient Neighbor Detection Protocol (EENDP) and which assigns the channel utilization. In this technique, the hello packet exchanges transmit based height and wavelength of the transmitter with particular distance. The computation of channel utility factor is the best method at link failure without data loss. The vitality utilization mathematical model is illustrated to show the nodes of least consumption by the broad recreation of utilization. The results observed from the proposed scheme shows that the energy level is minimized regarding the packet that loss is improved efficiently. In further, there are two results which can be gained in comparing with EENDP; firstly, packet delivery ratio and throughput get increased. And secondly, the end to end delay is decreased.

Keywords: MANET; Channelutilization; MAC; Schedulingpacketdeliveryratio; Throughput.

1. Introduction

1.1. Mobile ad hoc networks (MANETs)

MANET is primarily an accretion of mobile nodes without any base. Information packets are transmitted from head node to its sub-nodes. The execution of l (MAC) protocol gets to be productive when it has connected to the distinctive node of the environment. This System is self-operative in cell phones which are associated freely towards any direction or any network. Such systems are of multi-hop, self-arranging and self-designing network. It assists many services and forms wireless networks without any infrastructure; MANET is proposed primarily for critical emergency situations like military encounters and natural disasters.

1.2. Energy conservation

MANET nodes have expected for a portable with the limited power of this MANET source. The energy conservation is extremely challenging in different environments. The packet sends transmission node with guaranteed in the network connection where the energy level is minimized during the transmission in the MAC protocol by using some tech niques. This network changes the topology dynamically with consumed energy.

1.3. Channel assignment

A centralized algorithm is used to allow a channel to an LFSNDEEP protocol and to discover start of the link in a specific channel which is required to dispense with optional impedance it

is to minimize the arrangement of the connection having a most extreme need for transmission in each time slot. The MAC protocol bolsters the point to the multipoint mode is utilized are along with the expansion of the total transmission capacity to be accessible to the end client. Channels are allocated to each connection in the network to minimize the aggregate number of Channel Signal Handset that confines the from sending and accepting packets all the while in a single time-space. Essential obstruction is unavoidable in our system mode. A channel cannot be transmitted and received at the same time. The channel task issue has given a mesh network and its directing tree with the minimized quantity of channels required to maintain a strategic distance from the auxiliary obstruction from the network altogether. By appointing different channels to connect a primary obstacle to dodge wastage of the channel, use to minimize the quantity of channel. Need plan transmits the packet, reduces the number of time slots required for scheduling.

1.4. Scheduling in MANET

The scheduling algorithm is a process which determines the packet which is to be served next to the queue. It has placed between the routing and the MAC. If the scheduling has to be then these types of issue link network transmission will be delayed in increasing and packet losing node. The scheduling algorithm has to be appropriate for the descriptions given below. Therefore, the algorithm has to promote the overall network throughput. t is to enhance the throughput of the total network and to reduce the end to end delay. It is to improve the energy level which has compared with the neighbor detection algorithm. In a time division, multiple access method time slots are used to transmit and receive data. It

is found out with the help of scheduling algorithm to determine which packet should enter in the queue. The scheduler communicated between MAC layer and routing agent. In MANET an ideal scheduling algorithm should be adapted to dynamic changing of topology and limited bandwidth this network has to meet with QoS requirements like minimum bandwidth and maximum delay limitation.

1.5. Packet scheduling

In this method of packet scheduling, it has implemented between congestion level and series of path interval. In this scheme, the lifetime of the path is collected and estimated to find its validity. In every parameter, the channel condition is checked by the value of the path lifetime. The packet has been selected by high probability and the cost of link break.

1.6. Problem identification

The energy efficiency of MAC protocol in MANET has been proposed in the preceding work [13]. The very proposal is based on channel deployment and queue size. In this protocol, a channel has assigned with the optimal transmission power to check data packet, and Audio, Video packet, and compared to be neighboring node detection by which the energy level is maximized. In this paper, it is intended to propose an LFSNDEEP protocol with the scheduling algorithm in MANET.

2. Related work

R. Manikandan [9] algorithm has proposed a fair scheduling for mobile Ad Hoc networks. The performance of the MAC protocol is improved with the help of scheduling algorithm and link-utility. The performance of MAC protocol is enhanced by the scheduling algorithm which has the connection to the link-utility method. This algorithm allows number slots for each flow by using priority queue by using which the Optimal Transmission Power has been calculated with the help of priority queue.

P. Sivanesan [13] introduced an energy-efficient fair scheduling for an inelastic traffic flow which is proposed in MANET is proposed. The data traffic is differentiated into two categories elastic and inelastic technique makes delay whereas the proposed technique prioritizes elastic flow for data packet without any delay. The utility function of nodes is measured by the channel utilization, channel state information, and packet delay value. The data packet with high delay value is prioritized scheduled first.

Benjie Chen [1] used multihop ad hoc wireless networks that reduce energy consumption without significant capacity or connectivity in the MANET. Each node estimate of how many neighbor nodes being awake and the amount of energy available to it. Network Topology is used to increase the energy consumption. The Span on top of MAC power saving mode can improve throughput and packet delivery ratio.

K. B. Gurumoorthy [15] proposed Enhanced Medium Access control (EMAC) protocol. This protocol is helpful to find out the link failures, hidden terminal, and broadcast problems by using an adaptive mechanism with more energy consumption. The data to be transmitted with a minimum power level and saves wastage of energy. The DHN (Double Hop Neighborhood) graph of each station gives an estimation of power which is need for every transmission.

Krishna Kumar [3] proposed a power control MAC protocol in which the power in various transmission time. As a result, the power control mechanism increases the power level reduced to Node power consumption varying in transition time. Power control mechanism increases the power level, in the time of transmission range. The source node follows the neighbor node to find the capability and transmission rate of the parameter. Mesh topology increases the transmission rate and reduces the power allocation of each node. Power allocation of each level and the data rate of each

node in the system transmit the data to the node power level is minimum utilize by all the node are interconnected mesh topology since the node level energy is maximized.

3. Proposed solution

3.1. Overview

In this paper, the channel aware scheduling technique has been proposed for involatile and volatile flows in MANET are proposed. In our previous work, the best neighbor node had not found. By finding the best neighbor node, therefore, it is resulted to get minimum link-failure based on transmission type, rate, power, and bandwidth. When the data are transmitted by the node in the MAC protocol, the node selects the best neighbor node. The proposed technique sets the priority of data packet of an involatile flow. It is achieved as in light flow that requires a maximum delay requirement. In our proposed technique, it enhances the audio, video, and data packets of involatile flows are stored. The data packets are selected through based on the path lifetime value and cost of link break.

3.2. Neighbor node election

In our previous work, the neighbor qualification selection scheme is compared to a transmitter, receiver height with SNR. In this work, we implement the new neighbor qualification and election scheme which use the receiver height and wavelength instead of the transmission power of all links. Our previous work has been completed on the effectiveness of efficiency. The effectiveness has found out the number of neighbors and ability in energy consumption which spent the number of nodes and detection in the probability of time. Whenever the hello message is broadcast in a different period, the neighbor nodes are changed. In this paper, we employ the method of exchanging the hello packet with minimum interference SNR; estimate the transmission power, optimal transmission rate. The node transmits the Audio, Video packet to select the best neighbor based on the receiving antenna, wavelength upon which the buffer size is high.

3.3. Exchange hello packet with receiving signal strength

$$Prx = (Ptx \times dt \times dr \times ht \times hr \times w^2) / (4wD)^2 \times p$$

Ptx = Links transmission power; dt = Data transmitter gain, dr = Gain of the data receiver;

ht = Height of the transmitter; hr = Height of the receiver; w = Wavelength; D = Gap between transmitter and receiver; p = Packet loss, SNR = $\log_{10}(Ptx) - \log_{10}(Prx)$ dB

Packet loss based on SNR the SNR is the minimum level for transmitting Audio, Video packet.

Let P = Incoming signal power; I = interfering signal power and N = Noise to find out the packet loss SINR = $P / I + N$

3.3.1. Transmission power

Transmission power had been calculated already in various researchers. In this paper, the idea is proposed with forthcoming systems in which the transmission power is computed by three packets such as data, video and audio packets. The transmission rates are calculated by the following equation $\text{Sum}(R_{i,t}) \rightarrow R_{i,t}$ - Rate vector... each link rate vector Transmission Types are three packet type considered - Data packet, Audio, Video.

3.3.2. Computation of optimal transmission power and rate

Optimal transmits rate has estimated the power by selecting the neighbor node and source node to select destination which link is the best link. The transmission power vector contains the trans-

mission power of all links, and hence the optimal transmission rate is calculated by the following equation.
Compute the optimal transmission rate

$$R = \text{SSB} / (\lambda \times \text{MP}_s \times \text{GI}_{s_d}) / (\text{I}_{s_d} \times v)$$

SSB – Bandwidth

λ - Min SIN + Noise ratio

MP – Max Tx Power

I_{s_d} – Power at interference

v – Power for additive Gaussian noise

GI_{s_d} – Link gain

$$\text{I}_{s_d} = \sum (p_{i,t} * \text{GI}_{s_d})$$

Sum ($P_{i,t}$) -- $P_{i,t}$ -- Is Power vector at time.

We select the optimal value after checking the values of transmission power, but on the contrary, the transmission rate and its power had been calculated in the preceding work so far, and hence the transmission rates of various packets are not compared to the path lifetime and cost of link break. The proposed research has presented the optimal transmission rate which is estimated that the consumption of power level has been increased by selecting the best neighbor node in the destination link.

3.3.3. Calculation of packet delay

$$PI = R_{pi} - T_{pi}$$

R_{pi} – Packet receiving time

T_{pi} – Packet Transmission time

$$ND = PI$$

Find network delay = Sum (ND)

It improves link utility function

$$\text{Link utility} = \text{Utility} - \text{Cost}$$

Cost – Link break counts

Utility – Link utilization at time

When the packet arrives at receiving end, based on the signal to noise ratio compute packet delay with different time-based energy loss.

The node has the following state.

The active state has consumed more energy;

The passive state has node begin in the idle state spent less power than the active state and Sleep stage has a low level of energy consumption.

3.4. Scheduling phase

3.4.1. Channel aware packet scheduling

There is a proper scheduling process for mobile Ad hoc networks in which the node select the path and calculate the path lifetime and link break. The value of path duration has utilized items which represent the state of the end-to-end path. At the time of packet scheduling technique, it selects the parameters which reach the destination with efficiency as shown in Fig. 1. It takes the amount of the weight age of link break to give priority to log queue instead of a more extended break log queue.

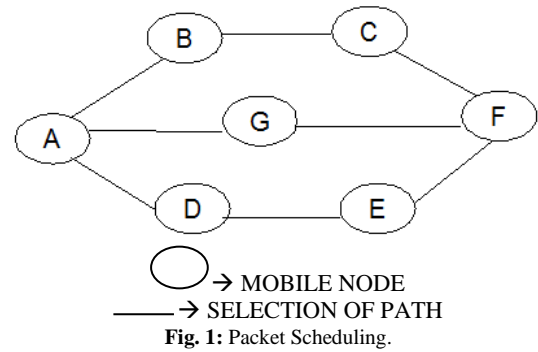

3.4.2. Method for flow selection

We select the path lifetime for the flow which is selected by channel aware packet scheduling is given in [2]. The following transmission power is helpful for to choose the flow, the packet which is the minimum used to queue namely channel aware packet scheduling algorithm, optimal transmission rate, and optimal transmission power.

3.4.3. Algorithm for packet scheduling

1. Start
2. Initialize $Q_i = \{Q_1, Q_2, Q_3 \dots Q_N\}$ (Set of Flows), $P(Q_i) =$ precedence Queue
3. $N =$ allocate the slot for every flow
4. $R =$ optimum transmission rate,
5. $P =$ optimal transmission power
6. If ($Q_i.N \leq Q_{i+1}.N \& Q_i.R \leq Q_{i+1}.R \& Q_i.pM \leq Q_{i+1}.P$) // scheduling
 { Queue plus flow are added $p(Q_i)$ }
7. Else
8. If ($p[Q_i] \neq 0$) // channel aware packets scheduling
9. {if ($p < \text{path life time}$)
 {
10. Select the packet with high probabilities & w [link break]
11. Insert flow F_i into the precedence queue
12. Else
13. Eliminate flow Q_i in the precedence queue
14. }
15. End

In this channel-aware scheduling, the primary requirement technique is known as checking, which has the best link of flow and assigns channel without any interference. Whenever the flow is arranged the unnecessary data are removed from the priority queue if the best link is unchecked. This process continues until the priority queue is emptied.

3.4.4. Channel access scheduling for involatile traffic flows in manet

In this channel access scheduling technique, involatile flows are prioritized our volatile flows data; audio, video packets are transmitted to the destination. The volatile, and involatile of flow, are helpful to the scheduling where a packet is sent. The scheduler allocates time slots for the packet in a volatile function three kind of packet belongs to involatile flow the scheduler checks the delay field in the utility function. The involatile technique selects the best neighbor node and low noise ratio with high space and a minimum level of link failure. Volatile, involatile technique number of the packet in the technique, to sort out the packet based scheduler on their packet delay. The involatile technique transmits data, audio, video packet transmits based on the best neighbor node in a scheduler compare the volatile technique.

Table 1: Volatile and in Volatile Flows

Audio, Video, Data Packets	Queue	Flow type
AP1,VP1,DP1	Q1	Volatile
AP2,VP2,DP2	Q2	In Volatile
AP4, VP5, DP6	Q3	In Volatile
AP7, VP7, DP7	Q4	In Volatile
AP8, VP8, DP8	Q5	Volatile
AP9, VP9, DP9	Q6	In Volatile
AP10,VP10,DP10	Q7	In Volatile

Where t = time of transmitting duration, Q1, AP2, VP2, DP2, Q2 and AP5, Q5 both are reaching the scheduling queue. Whenever, all types of packet are arrived the queue the scheduler watch the data packet according to the flow type from table1. The volatile and in volatile both type of flow & are select the scheduler based on the higher probability and maximum of the cost of link break.

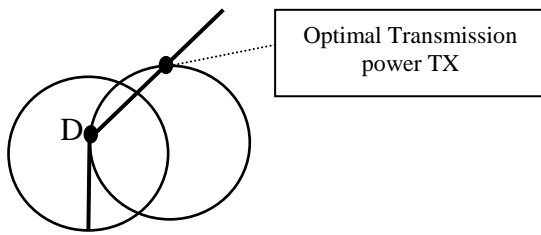

Fig. 2: Transmission Power.

3.4.4. Computation for channel assignment

The channel states information transceiver height, receiver height, wavelength and with which noise ratio, the rate of power for data delivery are enhanced using the volatile technique. It estimates how much optimum power is needed for audio, video packet transmissions, prioritizing the volatile flows and also improves the network lifetime.

4. Results and analysis

4.1. Mathematical proof

Theorem 1: A less amount of energy level which is to be distributed to the number of nodes where PF_is the probability of success and Boolean expression required an average of 1/PF_i trails.

Proof

The involatile flows make use of the user channel aware packet scheduling algorithm to get a minimized Boolean expression. The outcome of expression which occurs with a probability PF_i

Where Fi=set of flows, i= {1, 2, 3, 4, 5.....},

$$P (X=Fi+1) = (1-P) Fi+1-Fi PF_i$$

$$E(X) = \sum_{i=0}^{\infty} Fi+1 (1-P)Fi+1-Fi. PF_i \tag{1}$$

$$= \sum_{i=0}^{\infty} Fi+1.QFi+1-Fi. PF_i$$

$$\{P+Q=1\}$$

$$= \frac{PF_i}{QF_i} \sum_{i=0}^{\infty} Fi+1.QFi+1$$

$$= \frac{PF_i}{QF_i} [QFi(1-QFi)-2]$$

$$= \frac{PF_i}{QF_i} [QFi (PF_i)-2]$$

$$= (PF_i) X (PF_i)-2$$

$$= (PF_i) -1$$

$$\frac{1}{PF_i}$$

Similarly $\frac{1}{rFi}$ is proved

The above theorem proves that PF_i + QF_i = 1

Where P + Q =1

4.2. Simulation results

4.2.1. Simulation parameters

We use NS2 to simulate in the proposed protocol in our simulation. The capacity of the channel of mobile hosts is set to the same value: 2 Mbps. We use the Distributed Coordination Function (DCF) of IEEE 802.11 for wireless LANs as MAC layer protocol. A square meter of 1000 X 1000 is used as a bounded region in which a node is used with a uniform distribution of 100 mobile nodes for 75seconds of simulation time. We assume that each node moves independently with the same average speed. The power level of the node is assigned to the 75% of node coverage area. Therefore, the traffic which is stimulated is Constant Bit Rate [CBR] for all the audio and videos at a speed of 5m/s. The settings of stimulation and parameters have been summarized in the table. 1.

Table 2: Simulation Parameters Used in the Present Approach

Simulation Parameter	EENDP	LFSNDEEP
Density of Nodes	50	100
Simulation area	1000 X 1000	1000 X 1000
Node coverage	50%	90%
Simulation time	100	75 sec
Traffic Source	CBR	CBR,AUDIO,VIDEO
Packet size	512KB	1024MB
Initial energy	22.1J	25J
Transmission power	0.02w	0.99w
Routing protocol	AODV	AODV
Rate	50,100,150, 200kb	9000,9500, 10,000, 10,500kb
Receiving Power	0.9w	1.0w
Neighbor count	20	80

4.2.2. Performance Metrics

The performance of MAC protocol and that of channel-aware packet scheduling are compared. Therefore, the performance is evaluated by following metrics.

Packet Delivery Ratio (PDR): Ratio of the transmitting and receiving a packet at successfully.

$$PDR = \frac{\sum \text{No.of Packets received}}{\sum \text{No.of Packets Sent}}$$

Packet Drop: The transmission of a packet of the dropped range is average.

Throughput: Total number of bits get at the time is transmission process

$$\text{Throughput x 100} = \frac{\sum \text{No.of Packets received x 100}}{\sum \text{No.of Packets}}$$

End – To –End-Delay: Destination receives the packet to take the amount of time.

4.3. Experimental results

A CBR, Audio, Video traffic flows is varied as 9000, 10000, 11000, 12000 and 14000 for transmission rate. Performance analysis of two kinds of MAC protocol under the involatile technique and channel aware packet scheduling approach in MANET using NS2 is obtained on various scenarios. Each scenario is investigat-

ed for changes in performance metrics to increase the node energy level and throughput

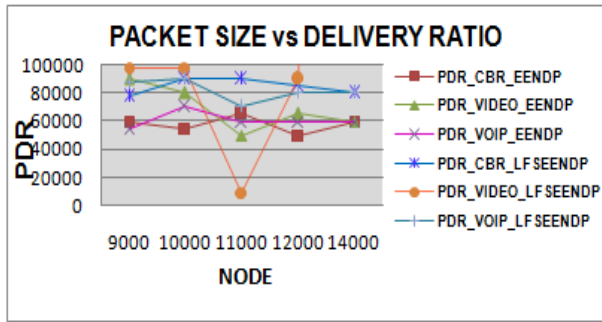

Fig. 3: Packet Size vs. Packet Delivery Ratio.

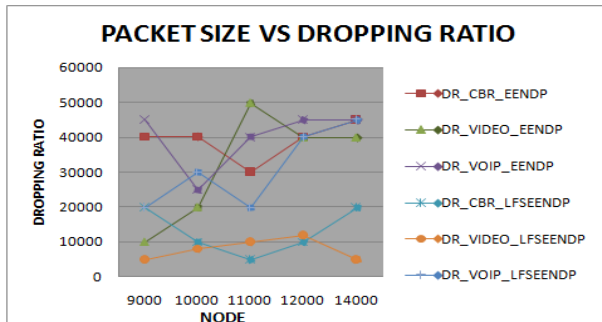

Fig. 4: Packet Size vs. Dropping Ratio.

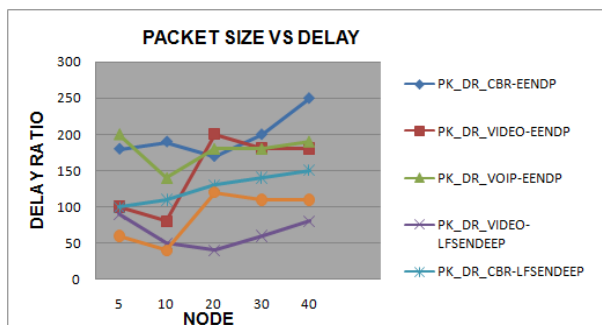

Fig. 5: Packets Size vs. Delay Ratio.

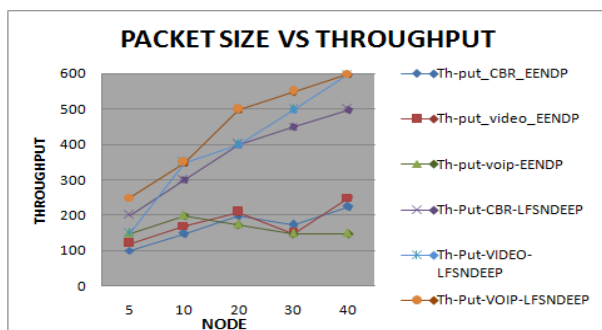

Fig. 6: Packet Size vs. Throughput.

Fig. 3 demonstrates the procedure of EENDP and LFSNDEEP system for the different rate of transmission. It has shown that the schedule of LFSNDEEP methodology has more than EENDP approach which is higher than 80%. The Protocol execution will be high in the given channel condition [2]. Fig. 4 depicts the dropping ratio of LFSNDEEP and EENDP methods for the various transmission rate situations. The dropping proportion is lower than EENDP approach. Fig. 5 exhibits the delivery ratio of data, Audio, Video parameter in an LFSNDEEP and EENDP systems for various transmission rate which is higher than (78%) in EENDP approach. While comparing EENDP and LFSNDEEP protocols, the packet drop of the latter is lesser, and the throughput is higher than the former which accomplishes a decent delivery ratio, contrasts with EENDP method. The channel state information of transceiver

height, wavelength, the rate of power for information data delivery and noise ratio are improved by utilizing involatile procedure [9]. It is evaluated the ideal power for packet transmission. Fig. 6 depicts the finding that the throughput proportion of all protocol is higher in LFSNDEEP protocol when it is compared with EENDP protocol. If the channel is free, transmission reach is high due to no sign impedance. Furthermore, throughput is high [13].

5. Conclusion

Mobile nodes are moving haphazardly with no brought together organization in MANET. In this paper, the energy efficiency is proposed which proper scientific means which enhance throughput with a comparative study of two protocols with channel access scheduling for involatile streams in MANET. The planning capacity is evaluated by considering channel and use, the channel state data along with the delay of data packets. The EENDP MAC protocol does not analyze the rate of audio, video packet ideal transmission rate yet in an LFSNDEEP protocol transmits the audio, video packets whereas t with an ideal of transmissions. The information packet with high delay value is organized and scheduled first. The proposed method is accomplished with advancements like decreasing delay and decreasing the consumption level of energy utilization by expanding the throughput. By the results of reproduction, we have demonstrated that our proposed routing protocol achieves higher packet delivery ratio and throughput levels, by diminishing the energy consumption, packet drop, and delay.

Acknowledgement

Dr. S. Neduncheliyan is known for his excellent guidance and complete this paper. The author is so thankful for arranging Network Lab, Department of Computer Science, Jaya College of Engineering & Technology, Chennai, Tamilnadu. This work could not have been accomplished without the necessary facilities available in the lab. The author would like to thank the technical personnel

References

- [1] Benjie Chen, Kyle Jamieson, Hari Balakrishnan and Robert Morris, "An Energy-Efficient Coordination Algorithm for To-pology Maintenance in Ad Hoc Wireless Networks," in Proceed-ings of the wireless network, 2002.
- [2] S.Sheeja, Dr.Ramachandra V Pujeri, "Efficient energy based congestion control scheme for mobile ad hoc networks," Journal of theoretical and applied information technology," 10th June 2014, vol 64.
- [3] Krishan Kumar, "power control with transition time for the ad-hoc wireless network," International Journal of Advanced Research in Computer Science, Volume 3, No. 3, May-June 2012.
- [4] Marco Valero, Sang Shin Jung, Anu G. Bourgeois, Raheem Beyah, " An incrementally deployable energy efficient 802.15.4 MAC protocol (DEEP)", Ad Hoc Networks (2012) PP No 1238–1252.
- [5] Kanika Garg, RishiPal Singh, " Scheduling Algorithms in Mobile Ad Hoc Networks," The International Journal of Com-puter Science & Applications (TIJCSA)- Volume 1, No. 5, July 2012.
- [6] Ren-Hung Hwang, Chiung-Ying Wang Chi-Jen Wu and Guan-Nan Chen ", A novel efficient power-saving MAC protocol for multi-hop MANETs," International Journal Of Communication Systems-(2011).
- [7] Shivani Rao, Sanjeev Khambra, " A Comparative Analysis of MAC Protocols in MANET," International Journal of Emerging Technology and Advanced Engineering -Volume 3, Issue 9, Sep-tember 2013.
- [8] Yongsheng SHI, T. Aaron GULLIVER, " An Energy-Efficient Mac Protocol for Ad Hoc Networks", - Wireless Sensor Network, 2009, PP No. 407-416.
- [9] R.Manikandan, K. Selvakumar, " link-utility-based improved back off cooperative mac protocol with fair scheduling for manet" Jour-

- nal of Theoretical and Applied Information Technology-20th Dec 2013. Vol. 58 No.2.
- [10] M. Nagaratna, V. Kamakshi Prasad, Raghavendra Rao," Performance Evaluation of Mesh-Based Multicast Routing Protocols in MANETs," International Journal of Advanced Computer Science and Applications, Vol. 2, No. 7, 2011.
- [11] Madan Mohan Nagar, Sunil Pathak, Dr. Sonal Jain," Design of Energy Efficient MAC Protocol with Increased Throughput in MANETs"- International Journal of Engineering and Innovative Technology (IJEIT) Volume 2, Issue 5, November 2012.
- [12] E.Vaidhegi, C.Padmavathy, T.Priyanga, A.Priyadharshini," Delay Sensitive Packet Scheduling Algorithm for MANETs by Cross Layer-International Journal of Innovative Research in Advanced Engineering (IJIRAE) Volume 1 Issue 1 (March 2014).
- [13] SIVANESAN, S. THANGAVEL," energy efficient mac protocol with fair scheduling Technique in manet", Journal of Theoretical and Applied Information Technology-20th July 2014. Vol. 65 No.2.
- [14] Jiajia Liu, Xiaohong Jiang, Senior Member, Hiroki Nishiyama, and Nei Kato," Throughput Capacity of MANETs with Power Control and Packet Redundancy"-, IEEE transactions on wireless communications, vol. 12, no. 6, June 2013. <https://doi.org/10.1109/TWC.2013.042413.121683>.
- [15] K.B.Gurumoorthy," Improved eMAC Scheme for Energy Efficient Communication in MANET,"- International Journal of Advanced Information Science and Technology, Vol.5, Iss.5, Sep2012.
- [16] J.Jaichinhiya,"Energy-based Scheduling Scheme for MA-NET," International Journal of Advanced Information Science and Technology, Vol.8, Iss.8, Dec2012.
- [17] Wen-Hwa Liao Sital Prasad Kedia, Avinash Kumar Dubey," Scheduling and channel assignment algorithm for IEEE 802.16 mesh networks using clique partitioning technique "-Computer Communications 35 (2012) 2025–2034. <https://doi.org/10.1016/j.comcom.2012.05.013>.
- [18] Hairong Yan, Jie Li, Guoji Sun, and Hsiao-Hwa Chen," An Optimalistic Power Control MAC Protocol for Mobile Ad Hoc Networks," IEEE-2006.
- [19] JEHN-RUEY JIANG, YU-CHEE TSENG, CHIH-SHUN HSU, TEN-HWANG LAI," Quorum-Based Asynchronous Power-Saving Protocols for IEEE 802.11 Ad Hoc Networks -Springer Science.
- [20] Hairong Zhou and Chihsiang Yeh, Hussein Mouftah," A Power-Efficient Medium Access Control Protocol for Heterogeneous Wireless Networks," IEEE-2006.
- [21] Tao Ma, Xinming Zhang, Guoliang Chen," A Maximal Clique Based Packet Scheduling Algorithm in Mobile Ad Hoc Networks".
- [22] Chuan-Chi Weng, Ching-Wen Chen, Po-Yueh Chen, Kuei-Chung Chang," Design of an energy-efficient cross-layer protocol for mobile ad hoc networks"- www.ietdl.org.
- [23] Jhunu Debbarma, Mrinal Kanti Debbarma, Sudipta Roy, Nikhil Debbarma, An Energy-Efficient Protocol for Power Conservation in Mobile Ad-hoc Networks- International Symposium on Computational and Business Intelligence-2013.
- [24] Yongsheng Shi and T. Aaron Gulliver, an Energy-Efficient Mac Protocol for Mobile Ad Hoc Networks.
- [25] Yiming Liu, Victor O. K. Li, Ka-Cheong Leung, and Lin Zhang, Topology-Transparent Distributed Multicast and Broadcast Scheduling in Mobile Ad Hoc Networks.
- [26] A. E. Narayanan, R. Devi And A. Vincent Jayakumar, An Energy Efficient Cluster Head Selection For Fault Tolerant Routing In Manet". International Journal of Engineering and Technology (Ijet).
- [27] Dimitrios J. Vergados, Aggeliki Sgora, Dimitrios D. Vergados, Periklis Chatzimisios," Joint Per-Flow Scheduling and Routing in Wireless Multihop Networks"*Education and Counseling* 53, 309–313.