

High space efficiency compact chipless RFID tag with equidistance resonances

Kholoud M. Ammar¹, Amr H. Hussein^{*1}, Mahmoud A. Attia¹

¹ Electronics and Electrical Communications Department, Faculty of Engineering, Tanta University, Tanta, Egypt

*Corresponding author E-mail: amrvips@yahoo.com

Abstract

Radio Frequency Identification (RFID) technology provides non line-of-sight communication between the reader and the tag. This technology is widely used for various applications such as item tracking, security, access control, health care, short and long-range applications. RFID can be used as low cost data identification technology using radio waves between the RFID transmitter and the RFID receiver. Many attempts are introduced to implement the chipless RFID tags but they suffer from non-equal spacing between resonances which makes it difficult to make the decision. In this paper, compact low cost spectral signature based chipless 8-bits RFID tag is introduced. Multi dual-band resonating circuits with different resonances are used. The operation bandwidth is limited by the second resonance of the resonator. To avoid the presence of harmonics in the operating frequency range, multiple resonators with different shapes are introduced. The proposed tag instead of encoding only one data bit it encodes two data bits providing higher bits/resonator. The proposed tag provides equidistance between resonance frequencies. The tag is implemented on FR4 substrate of dielectric constant $\epsilon_r=4.4$, thickness $h=1.6\text{mm}$ and loss tangent $\delta=0.0018$. The scattering parameters S_{21} of the fabricated tags are measured using the vector network analyzer (ROHDE&SCHWARZ ZVB 20). The designs of the tags are made using the software package CST MICROWAVE STUDIO.

Keywords: Radio Frequency Identification (RFID); Modified Complementary Split Ring Resonator (MCSRR).

1. Introduction

RFID is a remote data identification technology using electromagnetic signal. RFID system consists of two main components the RFID tag that carries the encoded data and the RFID reader to receive the data and decode it. The cost of the system depends on the tag's IC cost that contains a memory chip to store the encoded information, where tags with microchips are higher in cost than chipless tags manufactured with low cost components. Recently, there has been lots of research around the world to design and implement chipless RFID tags as it seems a promising solution. Each chipless tag contains passive circuitry that reflects back radio frequency waves to the reader. The data is decoded from these reflected radio waves. Frequency-coded chipless RFID tags encode data in frequency spectrum. The data is encoded as amplitude attenuation. Different techniques for implementing frequency-based chipless RFID tags are reported in [1-6]. Single-band resonators encode only 1 data bit and provide 1:1 ratio between the number of bits and resonators, they have the disadvantage of large size [1]. Dual-band resonators have been reported in [2], [3] to improve the space efficiency. Dual-band resonator tag presented in [2], encode 3^N words using N resonators. Only (00, 11 and 10) binary combinations can be provided. Modified Complementary Split Ring Resonator (MCSRR) encodes all combinations using one MCSRR where 4^N instead of 3^N words can be encoded. Polarization independent tags are reported in [5, 6]. These tags can be read from any orientation and in both near and far-field. Chipless RFID tags using multiple microstrip open stub resonators have been presented in [7]. These tags also suffer from non-uniform spacing between the successive resonances. In this paper, high space efficiency 8-bits RFID tag with equidistance resonanc-

es is proposed. The proposed tag is based on utilization of multiple dual-band resonance circuits resonating at different frequencies. The utilization of different resonance circuits with various shapes gives more freedom to implement the desired RFID tags as the designed circuits give harmonics of the fundamental frequency which are far enough to avoid the interference at the desired frequencies. Unlike previous reported dual-band tags that provide unequal spacing between resonance frequencies, the proposed tag provides equal spacing between the successive resonance frequencies, which enables the reader to easily and accurately decode the encoded data. 8-bits chipless RFID tag with operating frequency band from 2.5GHz to 6GHz is presented. The paper is organized as follows. Section 2 presents the basic operation principles of RFID system and the design of the proposed tag. Section 3 includes implementation of different 8-bits tags. Measured results of the fabricated tags are provided in Section 4 followed by conclusions in Section 5.

2. Proposed dual band resonators

In the frequency-based chipless RFID tag system, the reader sends interrogation signal to the tag. The tag encodes the data in the frequency domain using resonance circuits. Unique resonance frequencies will be obtained and the circuit will act as notch filter to the signal received, creating well-defined spectral signature, that is decoded by the reader. Each resonator provides two different resonance frequencies. The distance between each frequency is approximately 500 MHz. The equidistance spacing between each resonance frequency allows the reader to decode the encoded data in accurate manner.

2.1. Encoding binary “11”

Multiple resonance circuits are used to encode binary “11” at different frequencies. The resonance circuits 1 and 2 have the same shape with different dimensions. Resonance frequencies at 2.5 GHz, 3 GHz, 3.5 GHz, and 4 GHz are obtained by varying w_1 and w_2 . The remaining resonances are obtained using two different resonance circuits 3 and 4 where L_2 and L_3 are adjusted to obtain the resonance frequencies at 4.5 GHz, 5 GHz, 5.5 GHz, and 6 GHz. The dimensions and the corresponding scattering parameters of the proposed resonators for “11” encoding at different resonance frequencies are listed in tables (1-a), (1-b), (1-c), and (1-d).

2.2. Encoding binary “10”

Encoding the combination “10” at resonance frequencies 2.5 GHz, 3.5 GHz, 4.5 GHz, and 5.5 GHz is made using four resonance circuits. The first two resonance frequencies 2.5 GHz and 3.5 GHz are obtained by adjusting the length w_2 of the slot of the resonance circuits 5 and 6 as shown in table (2-a) and (2-b). The resonance circuits 7 and 8 are designed to resonate at frequencies 4.5 GHz

and 5.5 GHz respectively. The dimensions and the corresponding scattering parameters s_{21} of the proposed resonators are listed in tables (2-a), (2-b), (2-c), and (2-d).

2.3. Encoding binary “01”

For encoding the binary combination “01” at resonance frequencies 3 GHz, 4 GHz, 5 GHz, and 6 GHz four resonance circuits are used. The dimensions and the corresponding scattering parameters of the proposed resonators are listed in tables (3-a), (3-b), (3-c) and (3-d). The resonance circuits 9 and 10 have slots of length w_2 which controls and tunes the required resonance frequencies at 3 GHz and 4 GHz. On the other hand, the resonance circuits 11 and 12 are used to obtain the resonance frequencies 5 GHz and 6 GHz respectively.

2.4. Encoding binary “00”

The binary combination ‘00’ can be achieved, by removing the corresponding resonance circuit at the required frequencies.

Table 1: (A) Dimensions and the Corresponding Scattering Parameter S_{21} of the Proposed Resonator for “11” Encoding At Resonance Frequencies $F_1 = 2.48$ GHz and $F_2 = 3$ GHz

| parameter | Value mm | code | Scattering parameter (s_{21} in dB) |
|------------------------|--|------|--|
| W_1 | 14.5 | 11 |  |
| W_2 | 14.7 | | |
| L_1 | 10 | | |
| L_2 | 15.5 | | |
| h | 1.7 | | |
| Resonance circuit No.1 |  | | <p>Resonance frequencies: $f_1 = 2.48$GHz and $f_2 = 3$GHz</p> |

Table 1: (B) Dimensions and the Corresponding Scattering Parameter S_{21} of the Proposed Resonator For “11” Encoding At Resonance Frequencies $f_1 = 3.48$ GHz And $f_2 = 4$ GHz

| parameter | Value mm | code | Scattering parameter (s_{21} in dB) |
|------------------------|--|------|--|
| W_1 | 10.6 | 11 |  |
| W_2 | 10.6 | | |
| L_1 | 10.5 | | |
| L_2 | 14.5 | | |
| h | 1.2 | | |
| Resonance circuit No.2 |  | | <p>Resonance frequencies: $f_1 = 3.48$GHz and $f_2 = 4$GHz</p> |

Table 1: (C) Dimensions and the Corresponding Scattering Parameter S_{21} of the Proposed Resonator For “11” Encoding At Resonance Frequencies $f_1 = 4.5\text{ GHz}$ and $f_2 = 4.99\text{ GHz}$

| parameter | Value mm | code | Scattering parameter (s_{21} in dB) |
|---|--|------|--|
| W_1 | 0.7 | 11 |  |
| h | 2.1 | | |
| L_1 | 15.7 | | |
| L_2 | 9.2 | | |
| L_3 | 5.1 | | |
| Resonance circuit No.3 |  | | |
| Resonance frequencies: $f_1 = 4.5\text{GHz}$ and $f_2 = 4.99\text{GHz}$ | | | |

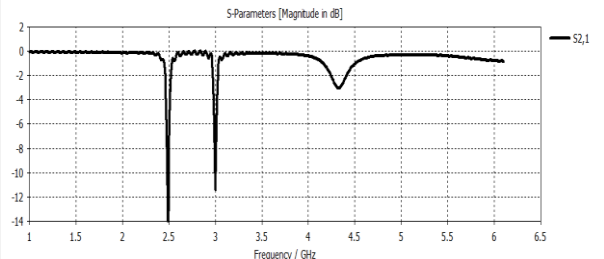
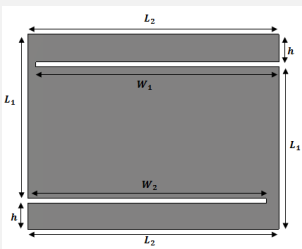
Table 1: (d) Dimensions and the Corresponding Scattering Parameter S_{21} of the Proposed Resonator for “11” Encoding at Resonance Frequencies $f_1 = 5.5\text{ GHz}$ and $f_2 = 6\text{ GHz}$

| parameter | Value mm | code | Scattering parameter (s_{21} in dB) |
|--|--|------|---|
| W_1 | 0.7 | 11 |  |
| h | 1.9 | | |
| L_1 | 17.5 | | |
| L_2 | 7.4 | | |
| L_3 | 8.1 | | |
| Resonance circuit No.4 |  | | |
| Resonance frequencies: $f_1 = 5.5\text{GHz}$ and $f_2 = 6\text{GHz}$ | | | |

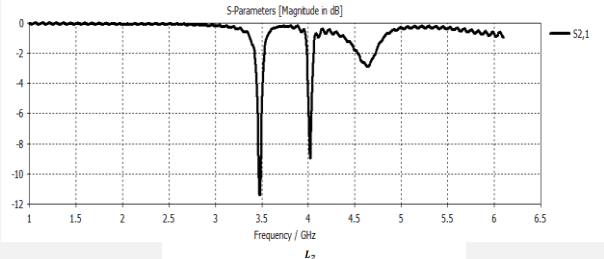
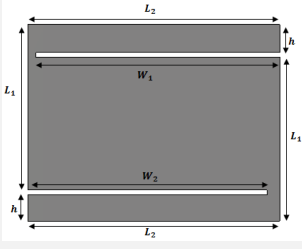
Table 2: (A) Dimensions and the Corresponding Scattering Parameter S_{21} of the Proposed Resonator for “10” Encoding at Resonance Frequency $f_1 = 2.49\text{ GHz}$

| parameter | Value mm | code | Scattering parameter (s_{21} in dB) |
|---|--|------|--|
| W_2 | 15 | 10 |  |
| h | 2.5 | | |
| L_1 | 12 | | |
| L_2 | 15.5 | | |
| L_3 | 9.2 | | |
| Resonance circuit No.5 |  | | |
| Resonance frequency: $f_1 = 2.49\text{GHz}$ | | | |

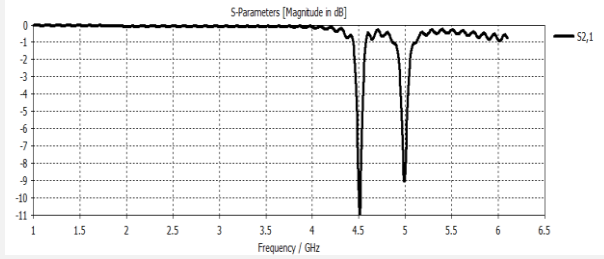
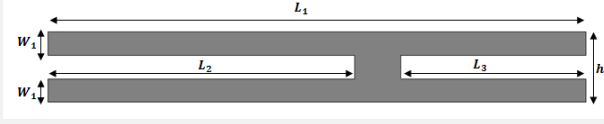
Table 2: (B) Dimensions and the Corresponding Scattering Parameter S_{21} of the Proposed Resonator for “10” Encoding at Resonance Frequencies $f_1 = 3.5\text{ GHz}$

| parameter | Value mm | code | Scattering parameter (s_{21} in dB) |
|--|----------|------|--|
| W_2 | 11 | 10 |  |
| h | 1.2 | | |
| L_1 | 12 | | |
| L_2 | 12.5 | | |
| L_3 | 10.5 | | |
| <p>Resonance circuit No.6</p>  | | | |
| <p>Resonance frequency: $f_1 = 3.5\text{GHz}$</p> | | | |

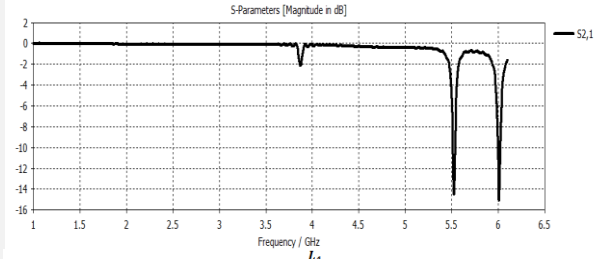
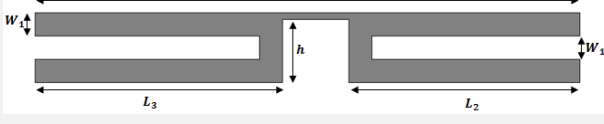
Table 2: (C) Dimensions and the Corresponding Scattering Parameter S_{21} of the Proposed Resonator for “10” Encoding At Resonance Frequency $f_1 = 4.5\text{ GHz}$

| parameter | Value mm | code | Scattering parameter (s_{21} in dB) |
|--|----------|------|---|
| W_1 | 0.7 | 10 |  |
| L_1 | 9.9 | | |
| L_2 | 2.1 | | |
| L_3 | 9.2 | | |
| L_3 | 9.2 | | |
| <p>Resonance circuit No.7</p>  | | | |
| <p>Resonance frequency: $f_1 = 4.5\text{GHz}$</p> | | | |

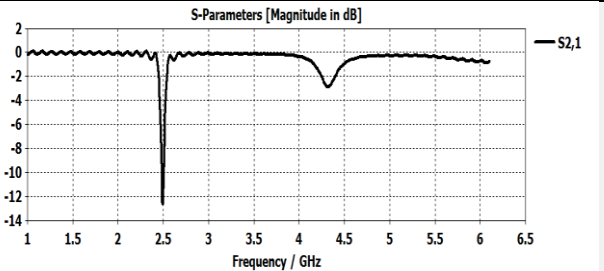
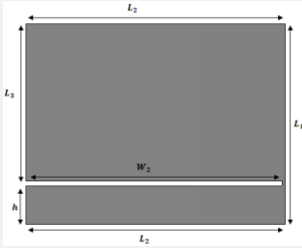
Table 2: (D) Dimensions and the Corresponding Scattering Parameter S_{21} of the Proposed Resonator for “10” Encoding at Resonance Frequency $F_1 = 5.5\text{ GHz}$

| parameter | Value mm | code | Scattering parameter (s_{21} in dB) |
|--|----------|------|--|
| W_1 | 0.7 | 10 |  |
| h | 1.9 | | |
| L_1 | 16.9 | | |
| L_2 | 6.8 | | |
| L_3 | 8.1 | | |
| <p>Resonance circuit No.8</p>  | | | |
| <p>Resonance frequency: $f_1 = 5.5\text{GHz}$</p> | | | |

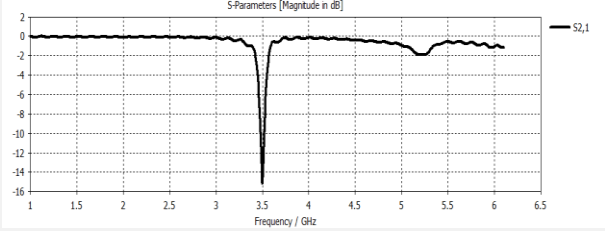
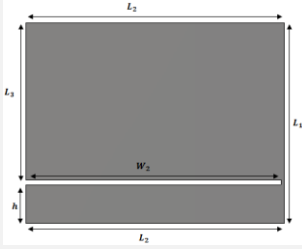
Table 3: (A) Dimensions and the Corresponding Scattering Parameter S_{21} of the Proposed Resonator for "01" Encoding at Resonance Frequency $f_2 = 2.99 \text{ GHz}$

| parameter | Value mm | code | Scattering parameter (s_{21} in dB) |
|------------------------|----------|------|--|
| W_2 | 13.1 | 01 |  |
| h | 1.7 | | |
| L_1 | 12 | | |
| L_2 | 15.5 | | |
| L_3 | 10 | | |
| Resonance circuit No.9 | | |  |

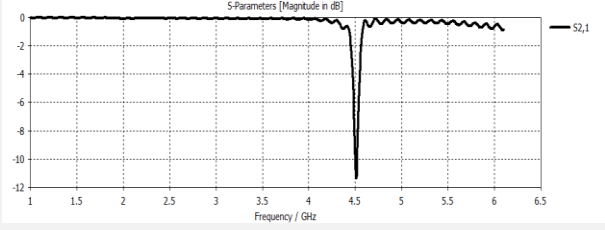
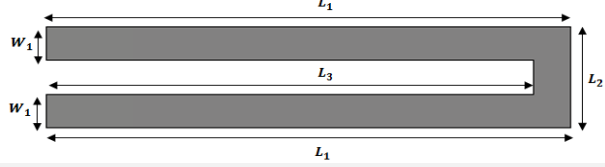
Resonance frequency: $f_2 = 2.99\text{GHz}$

Table 3: (B) Dimensions and the Corresponding Scattering Parameter S_{21} of the Proposed Resonator for "01" Encoding at Resonance Frequency $f_2 = 4 \text{ GHz}$.

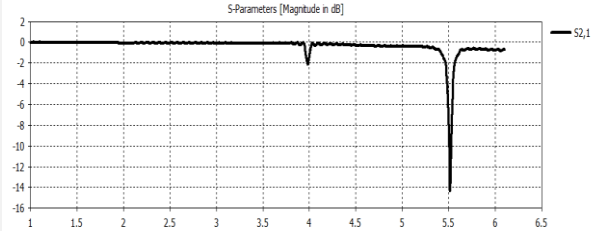
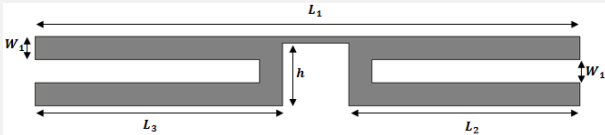
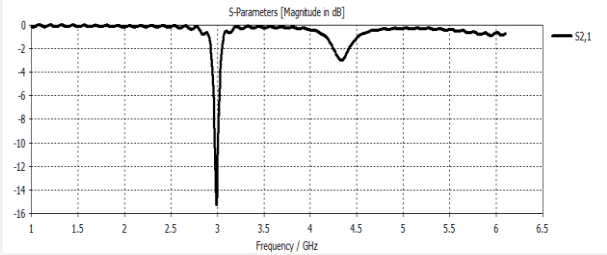
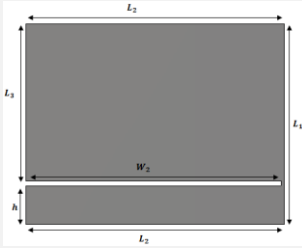
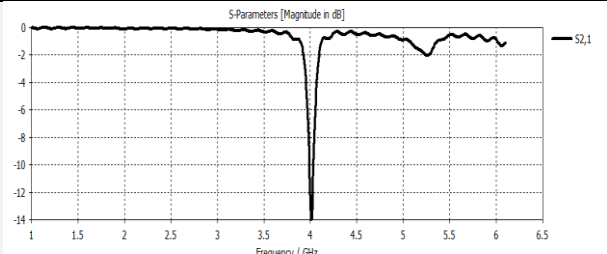
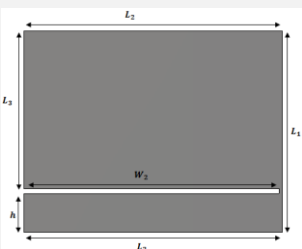
| parameter | Value mm | code | Scattering parameter (s_{21} in dB) |
|-------------------------|----------|------|--|
| W_2 | 9.3 | 01 |  |
| h | 1.2 | | |
| L_1 | 12 | | |
| L_2 | 12.5 | | |
| L_3 | 10.5 | | |
| Resonance circuit No.10 | | |  |

Resonance frequency: $f_2 = 4\text{GHz}$

Table 3: (C) Dimensions and the Corresponding Scattering Parameter S_{21} of the Proposed Resonator for "01" Encoding at Resonance Frequency $f_2 = 4.99 \text{ GHz}$

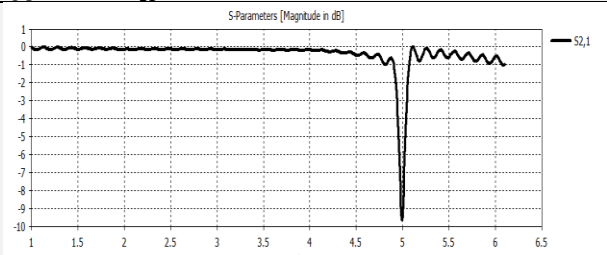
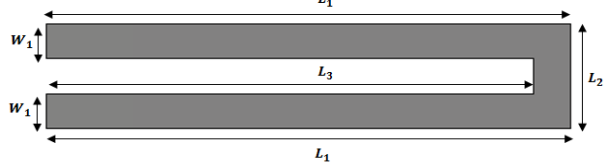
| parameter | Value mm | code | Scattering parameter (s_{21} in dB) |
|-------------------------|----------|------|--|
| W_1 | 0.7 | 01 |  |
| L_1 | 8.9 | | |
| L_2 | 2.1 | | |
| L_3 | 8.2 | | |
| L_3 | 8.2 | | |
| Resonance circuit No.11 | | |  |

Resonance frequency: $f_2 = 4.99\text{GHz}$

Table 3: (D) Dimensions and the Corresponding Scattering Parameter S_{21} of the Proposed Resonator for “01” Encoding at Resonance Frequency $f_2 = 6\text{ GHz}$

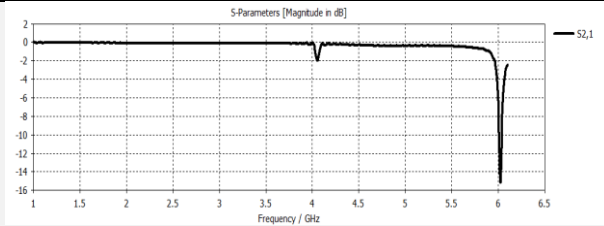
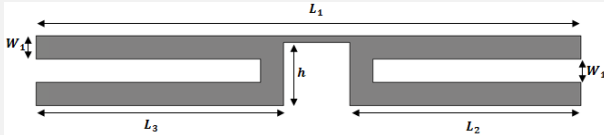
| parameter | Value mm | code | Scattering parameter (s_{21} in dB) |
|--|----------|------|--|
| W_1 | 0.7 | 01 |  |
| h | 1.9 | | |
| L_1 | 16.5 | | |
| L_2 | 7.4 | | |
| L_3 | 7.1 | | |
| Resonance circuit No.12 | | |  |
| Resonance frequency: $f_2 = 6\text{GHz}$ | | | |

3. Design of proposed RFID tags

Any 8-bits RFID tag can be easily designed using only four of the aforementioned 12 resonance circuits. In this section, several RFID tags with different IDs are introduced.

3.1. RFID tag design for id “10101010”

The ID “10101010” is realized by utilizing the four resonance circuits with the numbers (5, 6, 7 and 8) as shown in figure (1.a). The resulting s_{21} is shown in figure (1.b). The figures show that the designed tag provides equidistance between resonance frequencies with S_{21} values below -14dB .

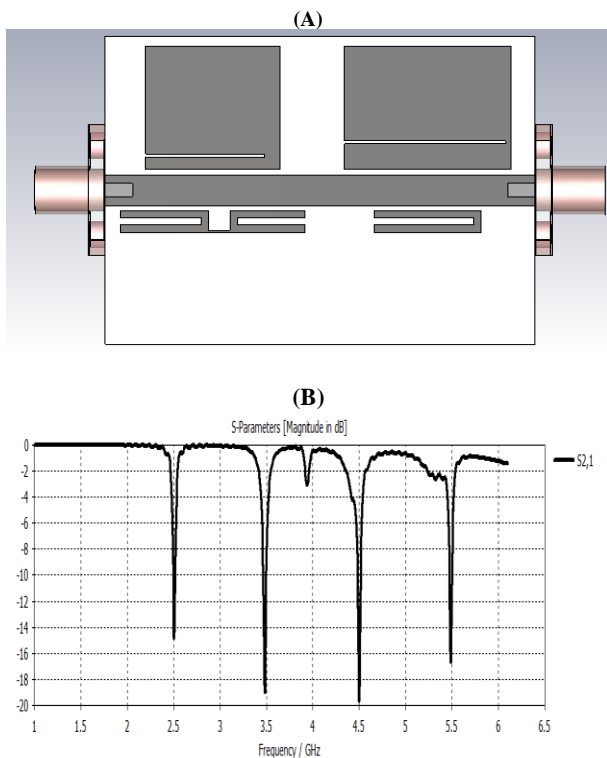

Fig. 1: (A) Layout of the Tag for Encoding ID “10101010”, (B) Simulated Insertion Loss (S_{21}) for the Tag with ID 10101010.

3.2. RFID tag design for id “01010101”

The ID “01010101” is realized by utilizing the four resonance circuits with the numbers (9, 10, 11 and 12) as shown in figure

(2.a) and the simulated S_{21} is shown in figure (2.b). The designed tag generates four resonances with equal spacing between them and the value of the simulated S_{21} is below -12dB .

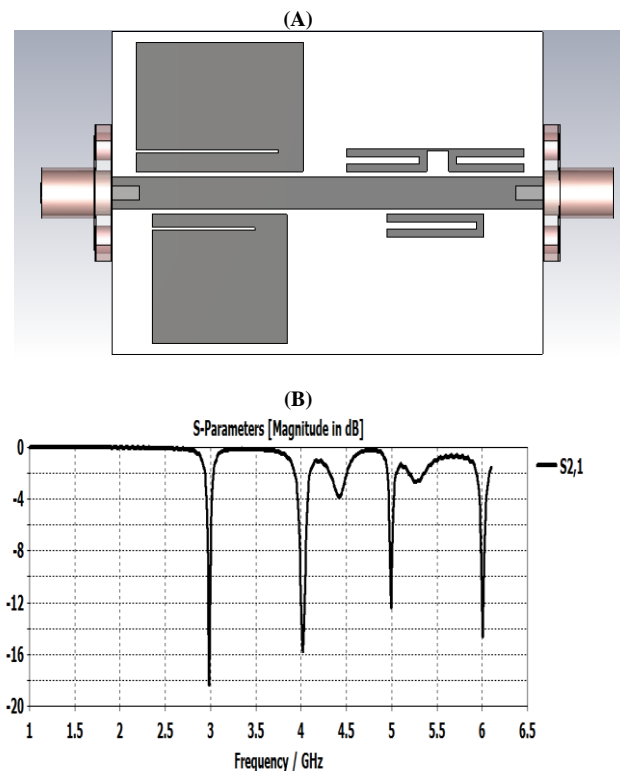

Fig. 2: (A) Layout of the Tag for Encoding ID “01010101”, (B) Simulated Insertion Loss (S_{21}) for the Tag with ID 01010101.

3.3. RFID tag design for id “11011011”

The ID “11011011” is realized by utilizing the four resonance circuits with the numbers (1, 4, 7 and 9) as shown in figure (3.a) and the resulting S_{21} is shown in figure (3.b). The resonator circuit is implemented in the following shape to provide adequate value for the insertion loss. The figure has only two zeros at 3.5GHz and 5GHz . The insertion loss peaks are less than -10dB .

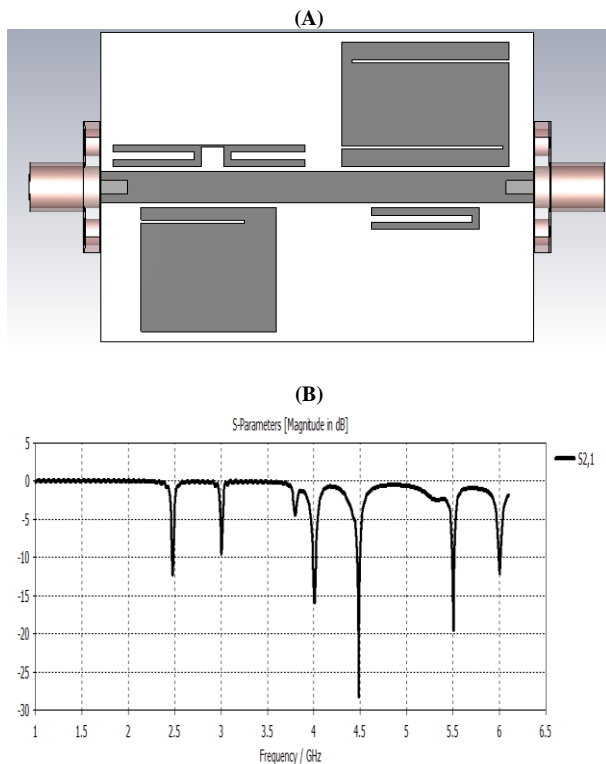

Fig. 3: (A) Layout of the Tag for Encoding ID “11011011”, (B) Simulated Insertion Loss (S_{21}) for the Tag with ID 11011011.

3.4. RFID tag design for id “10011111”

The ID “10011111” can be realized by utilizing the four resonance circuits with the numbers (3, 4, 5 and 10) as shown in figure (4.a) and the simulated S_{21} is shown in figure (4.b). The design also provides two zeros at the frequencies 3 GHz and 3.5 GHz. The value of the resulting S_{21} is below $-10dB$.

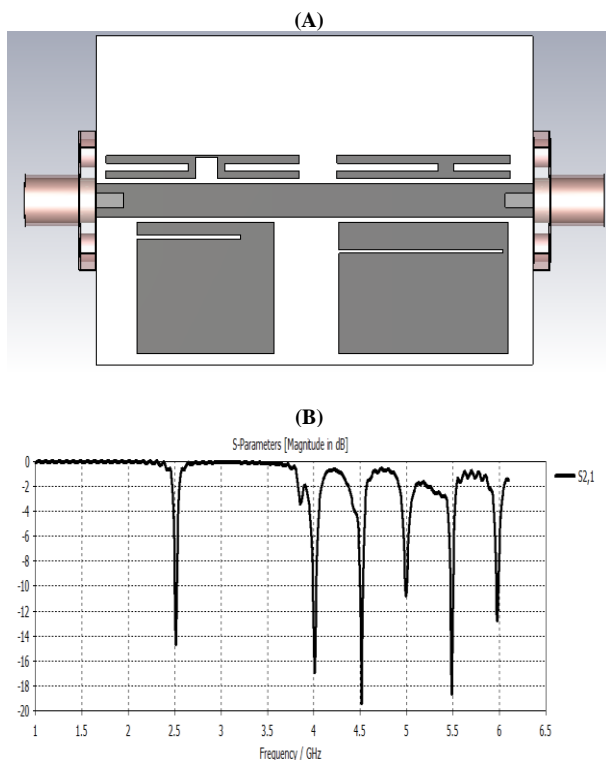

Fig. 4: (A) Layout of the Tag for Encoding ID “10011111”, (B) Simulated Insertion Loss (S_{21}) for the Tag with ID 10011111.

3.5. RFID tag design for id “11111111”

The ID “11111111” can be realized by utilizing the four resonance circuits with the numbers (1, 2, 3 and 4) as shown in figure (5.a) and the corresponding S_{21} is shown in figure (5.b).

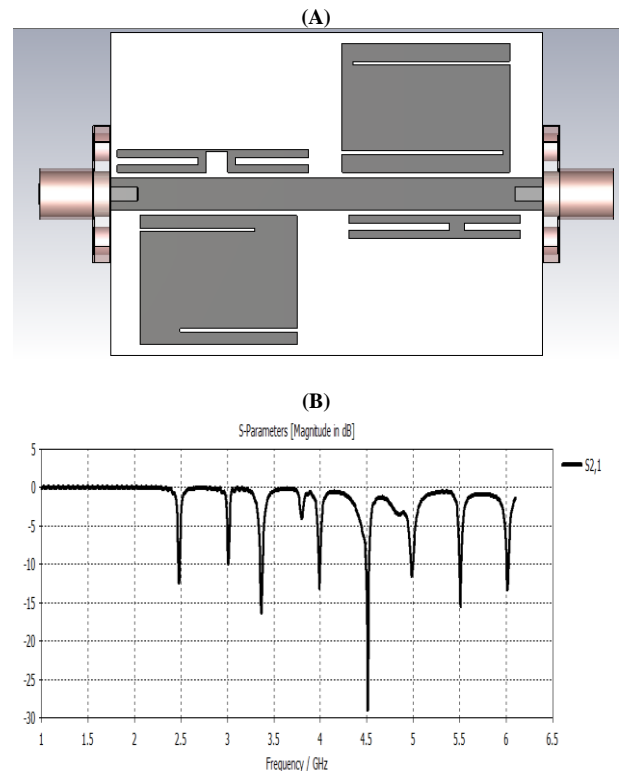

Fig. 5: (A) Layout of the Tag For Encoding the ID “11111111”, (B) Simulated Insertion Loss (S_{21}) for the Tag with ID 11111111.

4. Experimental results

Two 8-bit RFID tags are fabricated using FR4 substrate of dielectric constant $\epsilon_r = 4.4$, loss tangent $\delta = 0.0018$ and thickness $h = 1.6 \text{ mm}$. The fabricated tags are those having the IDs: “11111111” and “10101010”. The designs of the tags are shown in figures 6 and 7 respectively. The scattering parameters S_{21} of the fabricated tags are measured using the vector network analyzer (ROHDE&SCHWARZ ZVB 20). The designed tag with ID “10101010” has four non-overlapping stop bands where the measured values of S_{21} lie within $-12dB$ to $-15dB$ range. For the tag with ID “11111111” eight non-overlapping stop bands are generated where the measured values of S_{21} extends from -7.5 dB to -15 dB . The small shift in the resonant frequency is due to mutual coupling between the resonators. Therefore, the proposed tags can represent binary information with insertion loss measurements that correspond well to the required data to be encoded.

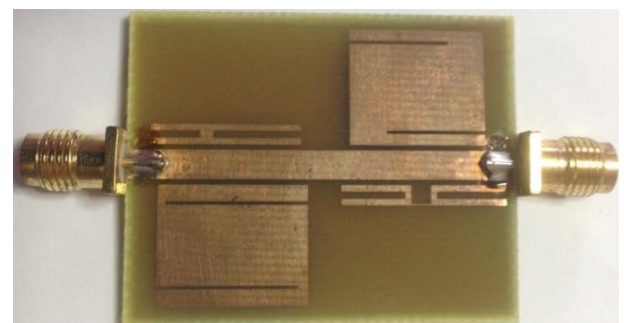

Fig. 6: Hardware Implementation of the Tag for Encoding the ID “11111111”.

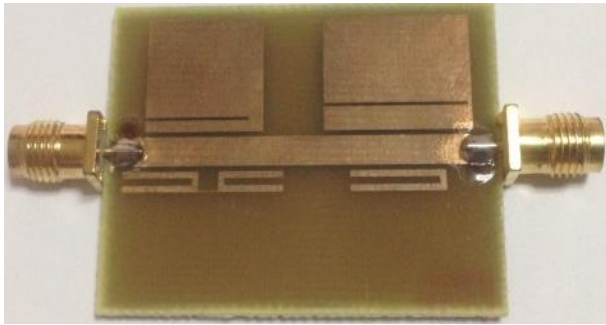

Fig. 7: Hardware Implementation of the Tag for Encoding the ID "10101010".

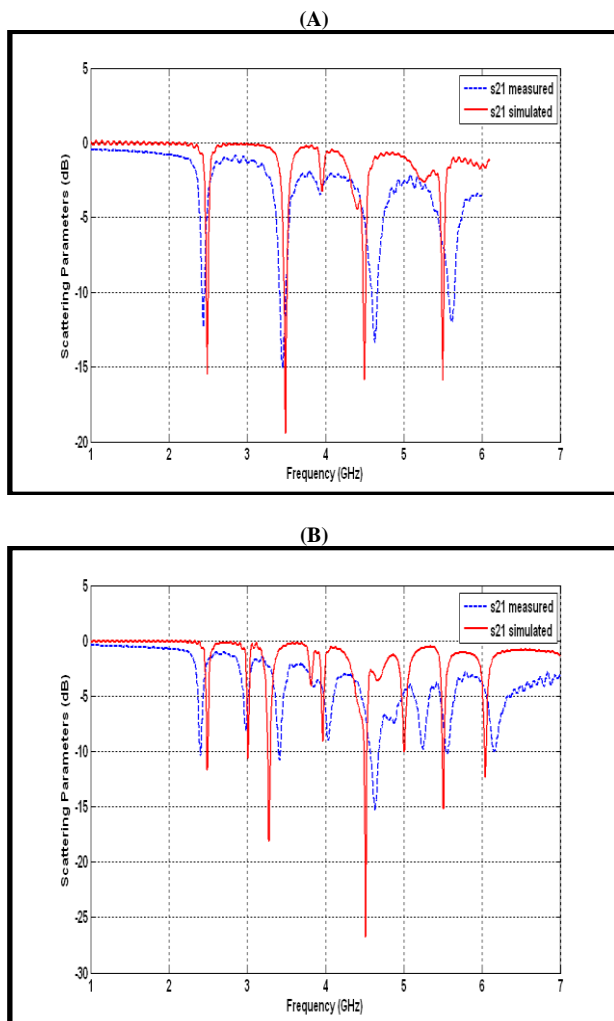

Fig. 8: Comparison of Simulated and Measured S_{21} . (A) Encoding the ID "10101010", (B) Encoding the ID "11111111".

5. Conclusion

In this paper, compact spectral signature based chipless RFID tags are presented. Dual-band chipless RFID tags with high space efficiency are designed, fabricated and tested. Different shapes of resonance circuits are utilized to provide more freedom and flexibility in the design. The tag can encode 8-bit data of any binary ID. The equidistance resonances provide an advantage over the other tags in encoding and decoding the data with high accuracy. Multiple measurements were obtained for the scattering parameter s_{21} for different code IDs. The measured and the simulated results of s_{21} are highly coinciding over the dedicated frequency band

References

- [1] M. Sumi, R. Dinesh, C. M. Nijas, S. Mridula, and P. Mohanan, "High Bit Encoding Chipless RFID Tag Using Multiple E-Shaped Microstrip Resonators," *Progress In Electromagnetics Research B*, Vol. 61, pp.185-196, 2014. <https://doi.org/10.2528/PIERB14081301>.
- [2] M. S. Bhuiyan, and N. C. Karmakar, "An Efficient Coplanar Re-transmission Type Chipless RFID Tag Based On Dual-Band MCSRR," *Progress In Electromagnetics Research C*, Vol. 54, pp.133-141, 2014. <https://doi.org/10.2528/PIERC14061403>.
- [3] D. Girbau, J. Lorenzo, A. L'azaro, C. Ferrater, and R. Villarino, "Frequency-coded chipless RFID tag based on dual-band resonators," *IEEE Antennas Wireless Propagation Letters*, Vol. 11, pp. 126–128, 2012. <https://doi.org/10.1109/LAWP.2012.2185032>.
- [4] S. Preradovic, I. Balbin, N. C. Karmakar, and G. F. Swiegers, "Multiresonator-based chipless RFID system for low-cost item tracking," *IEEE Transactions on Microwave Theory and Techniques*, Vol. 57, pp. 1411–1419, 2009. <https://doi.org/10.1109/TMTT.2009.2017323>.
- [5] M. A. Islam, Y. Yap, N. C. Karmakar, and A. Azad, "Compact printable orientation independent chipless RFID tag," *Progress In Electromagnetics Research C*, Vol. 33, pp. 55–66, 2012. <https://doi.org/10.2528/PIERC12071306>.
- [6] A. Vena, E. Perret, and S. Tedjini, "High capacity chipless RFID tag insensitive to the polarization," *IEEE Trans. Antennas Propag.*, Vol. 60, No. 10, pp. 4509–4515, 2012. <https://doi.org/10.1109/TAP.2012.2207347>.
- [7] C. M. Nijas, R. Dinesh, U. Deepak, A. Rasheed, S. Mridula, K. Vasudevan, and P. Mohanan, "Chipless RFID tag using multiple microstrip open stub resonators," *IEEE Trans. Antennas Propag.*, Vol. 60, No. 9, pp. 4429–4432, 2012. <https://doi.org/10.1109/TAP.2012.2207081>.