

Smart home based security system for door access control using smart phone

Satvika Marrapu ^{1*}, S. Satyanarayana ², V. Arunkumar ³, J. D. Sai Krishna Teja ³

¹ Computer Science and Engineering, Koneru Lakshmaiah Education Foundation, Vaddeswaram, India

² Professor Computer Science and Engineering, Koneru Lakshmaiah Education Foundation, Vaddeswaram, India

³ Computer Science and Engineering, Koneru Lakshmaiah Education Foundation, Vaddeswaram, India

*Corresponding author E-mail: marrapusatvika@gmail.com

Abstract

The system is regarding the remotely overseen Door availability and voice alarming with the help of Smart Phone. It captures the guest picture at the Door as Email caution. Use of Smart home security control framework became essential in our day to day life. This paper describes the outline of an advanced home security framework. In this method the door availability has been controlled based on guest character by considering the human movement location and remotely checking innovation. This paper describes the remote control framework execution and organization and allows the validated individuals in to a home as it were. This Security Framework can be implemented by using switch/calling bell and a Camera module. The camera module captures the pictures of the guest separately and ideally to make the home security framework alive on demand. In this method we used an Electromagnetic entryway bolt module which created the entryway availability. This proposed framework deploys a controller interface framework and LPC 2148. If a guest press calling bell at the door then the web Camera module is interfaced with switch to capture pictures and send these pictures as Email caution with the help of TCP/IP protocol. Now, we can control this home security system by seeing camera module video stream with the help of Smart cell Phone. Like this, the proposed home security framework allows us for sending an order as a reply of voice ready whenever the gatecrasher recognized using smart phone. By using android stage and improved JavaScript, the Clients can see the guest on the screen and able to control the entryway by locking or unlocking the door. This software can be used in a wide range of application where the physical nearness can't be possible forever i. e in territories. The entire control framework is implemented with LPC 2148 now a days usage of smart lock system is increasing day by day in wide range of applications. This efficient effort less low power calling bell based home lock system is essential for security purpose in every home and offices. So many nations are worked on home based locking framework to implement advanced technologies in it. Most of smart houses and business offices are associated with a chip for security purpose. Though numerous advancements take place, the clients face troubles i. e interface problems in utilizing this smart lock system. To avoid such type of issues i proposed microcontroller. This advanced home security system is useful for real time home environment.

Keywords: Web Camera Module; Door Access; Voice Alert; Switch/Calling Bell; Email Alert.

1. Introduction

The smart home based security system for door access control using smart phone. In this, we used a 2 way protocol and programmed interface for sending alerts to the clients and as well as for gadgets i.e smart phone which they used. The main motto of typical security system is detects the person who enter at entry level when the switch operated and send an alert to the user. Then client can monitor the guest who entered and open the door using gadget. In proposed method,

2. System architecture

The Brilliant home based security framework consists two segments. Those are Embedded Control Unit (ECU) and Remote control unit (RCU). Embedded Control Unit (ECU) used in home Security system executes and controls all commends properly where as the Remote Control Unit (RCU) detects the signals and communicates with respective things through smart mobile phone. A. the Embedded Control Unit (ECU) ECU is low power, an ef-

fective, and easily installable. It controls the entire system for providing smart security to a home and allows the user for remote observing and as well as for controlling. Embedded control unit having a LPC 2148 set up. When guest operated the calling bell at door then the web cam will be activated to catch pictures. The web cam saves the guest image or video stream on it's SD card. The Embedded control unit consists a program which allows the user in controlling the Electromagnetic Door and the Loud Speaker system for Voice alerts. The Remote Control Unit allows the client to control the Door with the help of their Smart Phone. RCU is actualized with android based Java Script smart mobile.

3. Block diagram

The Smart Home Security System block diagram is displayed as figure 1 in this paper. The whole home security Framework has implemented with LPC 2148 ARM, web Camera and Power supply at the place where want security. The micro controller 2148 which is used in smart home security system executes all the instructions given by client, switch and web camera.

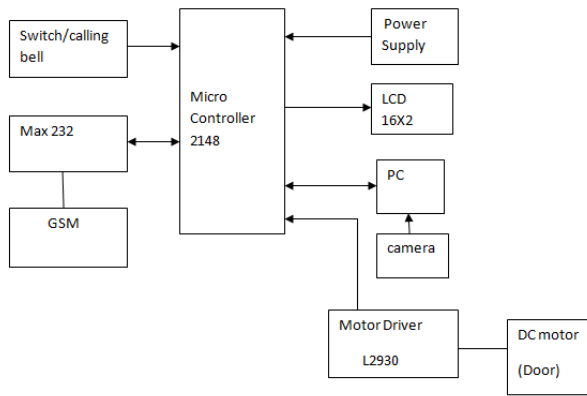

Fig. 1: Block Diagram.

The functionality of efficient home security system which is proposed has described in the following section. When a calling bell or switch is pressed by guest then the instructions are passed to micro controller. It alerts the web cam. Then cam module has been activated to capture the image or video of the guest and save it on SD Card. These images are sent to the client through email and also give the voice alert to the user. Then, the client can monitor the guest who entered at the door and access the entry through smart phone. It is simple and efficient smart home security framework.

4. System description

The Embedded control unit and remote observing unit has automated over the internet by providing a certain system program. For an example, take Secure shell protocol and IPV6 [3]. If any guest enters, at the door then Embedded Control Unit captures the guest picture with a camera, and sends those images with time and date when captured to a registered email id. The images can be monitored in android based smart phone by client and he/she login directly and gives instructions to ECU. The user can access video stream of the guest straight forwardly and control the door by using a Static IP address.

4.1. LPC 2148

The LPC2148 is an ARM 7 architecture. This SOC is used in microcontrollers and micro processors. This ARM was developed by NXP Semiconductors. ARM 7 is widely used in embedded systems. The basic pin configuration of ARM 7 LPC 2148 is as follows.

4.1.1. Memory

LPC2148 consists of an on chip Static RAM (32kB) and FLASH memory (512kB). It has 2kB built in RAM. The flash memory is useful for coding and data storage. The LPC2148 is available in 8, 16 and 32 bits. The Random access memory also stores the data and code.

4.1.2. Input/ output ports

It has 2 input/output ports. Both are 32 bit wide. These 2 ports are called as P0 and P1. Both are useful for different functions. It is suitable for real time applications due to its wonderful built in features.

4.2. Port 0

The 28 pins of P0 is used as general purpose I/O. These are bidirectional pins. The 31st pin on the port 0 works as digital output. The port 0 function depends on pin connect block. Pins 24, 25, 26 and 27 are unavailable.

4.3. Port 1

It is also bidirectional Input/output port. Depending on pin selection, the Port 1 works. 0 - 15 pins of port 1 is not working. The P0 and P1 are controlled by 2 register groups which are described in the following section.

4.3.1. IOPIN

It is also called as GPIO value register. It presents the status that can be available with this register.

4.3.2. IODIR

It is also called as GPIO port direction control register. Each port pin direction can be controlled individually by using this register.

4.3.3. IOCLR

Another name of this register is GPIO Port Output Clear registers. The output pins status can be controlled with the help of IOCLR.

4.3.4. IOSET

It is the Output Set registers of GPIO Port. IOSET also controls output pins status

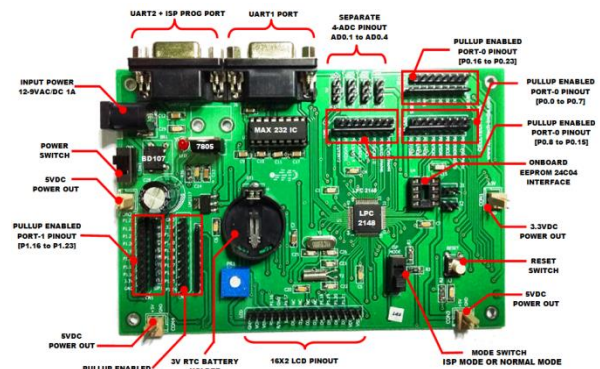

Fig. 2: ARM 7 LPC 2148.

4.4. WEB camera module

The webcam is interfaced with the person computer or computer network. It captures the images in real time and automatically saves it. After that it can be sent to various networks via internet or an email attachment. Usually the web cam is connected to a PC or any other device through USB cable. In laptop it comes as built in device. The webcam means which connected to the internet or web continuously and send original scene to any one in real time. In this smart home base security system, the web cam captures the guest images when the bell rings and send to the client through Email.



Fig. 3: Web Camera.



Fig. 5: Screenshot of Email Alert on Internet Browser - Result 1.



Fig. 6: Screenshot of Email Alert on Internet Browser - Result 2.

5. Conclusion

This paper describes the usage of an efficient low power Smart home based security framework using smart phone with Email communication, web video stream and remote control Voice alert and Door opening & locking. The hardware is implemented with a programmed micro controller, a camera module, calling bell and smart phone. We can also replace the smart phone with a personal computer. By using this technique, any type of remote gadgets can be programmable micro controller to send and control data for handling supplies over Internet.

References

- [1] Mrutyunjaya Sahani, Chiranjiv Nanda, Abhijeet Kumar Sahu and Biswajeet Pattnaik, "Web-Based Online Embedded Door Access Control and Home Security System Based on Face Recognition" 2015 International Conference on Circuit, Power and Computing Technologies [ICCPCT]. <https://doi.org/10.1109/ICCPCT.2015.7159473>.
- [2] Rhythm Haji, Arjun Trivedi, Hitarth Mehta, Prof. A.B. Upadhyay "Implementation of Web-Surveillance using Raspberry Pi" International Journal of Engineering Research & Technology (IJERT) Vol. 3 Issue 10, October- 2014, IJERT.
- [3] Jinsoo Han; Chang-Sic Choi; Ilwoo Lee, "More efficient home energy management system based on ZigBee communication and infrared remote controls," Consumer Electronics, IEEE Transactions on, vol.57, no.1, pp.85,89, February 2011.
- [4] Erdem, H.; Uner, A., "A multi-channel remote controller for home and office appliances," Consumer Electronics, IEEE Transactions on, vol.55, no.4, pp.2184, 2189, November 2009. Yuksekkaya, B.; Kayalar, A.A.; Tosun, M.B.; Ozcan, M.K.; Alkar, A.Z., "A GSM, internet and speech controlled wireless interactive home automation system," Consumer Electronics, IEEE Transactions on, vol.52, no.3, pp.837,843, Aug. 2006.
- [5] Chia-Hung Lien; Ying-Wen Bai; Ming-Bo Lin, "Remote-Controllable Power Outlet System for Home Power Management," Consumer Electronics, IEEE Transactions on, vol.53, no.4, pp.1634,1641, Nov. 2007. Vernon, S.; Joshi, S.S., "Brain-Muscle-Computer Interface: Mobile- Phone Prototype Development and Testing," Information Technology in Biomedicine, IEEE Transactions on, vol.15, no.4, pp.531, 538, July 2011.

- [6] Faundez-Zanuy, M. Are inkless fingerprint sensors suitable for mobile use? IEEE Aerospace and Electronic Systems Magazine, Vol. 19, No.4, pp. 17-21, April 2004.
- [7] I.S. Jacobs and C.P. Bean, "Fine particles, thin films and exchange anisotropy," in Magnetism, vol. III, G.T. Rado and H. Suhl, Eds. New York: Academic, 1963, pp. 271-350. <https://doi.org/10.1109/MAES.2004.1301769>.
- [8] K. Elissa, "Title of paper if known," unpublished. R. Nicole, "Title of paper with only first word capitalized," J. Name Stand. Abbrev, in press.
- [9] Y. Yorozu, M. Hirano, K. Oka, and Y. Tagawa, "Electron spectroscopy studies on magneto-optical media and plastic substrate interface," IEEE Transl. J. Magn. Japan, vol. 2, pp. 740-741, August 1987 [Digests 9th Annual Conf. Magnetics Japan, p. 301, 1982].
- [10] M. Young, the Technical Writer's Handbook. Mill Valley, CA: University Science, 1989. <https://doi.org/10.1109/TJM.1987.4549593>.