

Smart wheelchair using android smartphone for physically disabled people

Siti Nur Suhaila Mirin ^{1,*}, Khalil Azha Mohd Annuar ¹, Chai Pui Yook ¹

¹ Department of Electrical Engineering Technology, Faculty of Engineering Technology, Universiti Teknikal Malaysia Melaka, Hang Tuah Jaya, 76100, Durian Tunggal, Melaka, Malaysia

*Corresponding author E-mail: nursuhaila@utem.edu.my

Abstract

This paper describes the development of a smart wheelchair system with voice recognition and touch controlled using an embedded system. An android application is developed and installed on the android smartphone. The system is divided into two main modes: voice recognition mode and touch mode. For the voice recognition mode, elderly or physically disabled people (users) can provide the voice input, for example, “go”, “reverse”, “turn to the left”, “turn to the right” and “stop”. The wheelchair will move according to the command given. For the touch mode, the user can select the specified direction displayed within the four quadrants on the screen of the android smartphone to control the wheelchair. An Arduino Uno is used to execute all commands. The MD30C motor driver and HC05 Bluetooth module are used in this system. This system is designed to save time and energy of the user.

Keywords: Smart Wheelchair; Bluetooth Module; Touch Mode; Voice Recognition Mode; Android.

1. Introduction

Due to the increased percentage of elderly and physically disabled people, wheelchairs are the best assistive devices to help them enhance their personal mobility. The traditional wheelchairs have some limitations such as flexibility, bulkiness and limited functions [1-2]. There are existing technologies which allow the users to use human gestures such as the movements of hands, movements of leg [3-4], tongue [5] and head [6-7], and synchronize them with the movements of the wheelchair for a better wheelchair controls for example smart wheelchair.

A smart wheelchair is developed to help an elderly or physically disabled person (user) to move from one place to another independently. An android application is developed and installed in the android smartphone. It consists of two controlled modes, the first mode is the touch mode and the second mode is the voice recognition mode [8]. In the first mode, the user can give the voice input using an android smartphone. The android smartphone will convert the voice commands into a string of data and this string of data will be sent to the Bluetooth module and lastly delivered to Arduino Uno. After that, Arduino will decode and process it. The motor driver will direct the wheelchair according to the command given. When the user says “go”, the wheelchair will move forward, the word “reverse” causes the wheelchair to move backward, the word “turn to the left” causes the wheelchair to turn left, and the word “turn to the right” causes the wheelchair to turn right.

For the second mode, the user can determine the wheelchair’s movement by selecting the desired direction on the android smartphone screen. The command given by the user will be forwarded to the Arduino Uno via Bluetooth. The Bluetooth will convert the commands given by the user in a binary format and send them to the Arduino Uno. Arduino Uno will read and execute the command and lastly send the digital values to the motor driver device. The motor driver will direct the wheelchair according to the

command given. When the user selects the “Go” arrow, the wheelchair will move in a forward direction, “Back” arrow prompts the wheelchair to move backward, and “Left” arrow causes the wheelchair to turn left, and “Right” arrow makes the wheelchair turn right [9]. An elderly or physically challenged person can direct the direction and movement of the wheelchair with the help of the android smartphone in four different directions, left, right, forward, reverse and stop. The wheelchair will move according to the command given by the user.

In [10] presented an idea of an eye controlled system which enables the movement of wheelchair depends on the movements of eye-balls. A camera is mounted on the wheelchair; the wheelchair can move in a certain direction when the user looks at that direction by making eye movements. Based on the eye-detected location, the direction of the possible motion is found, the command is transmitted to the motor control device via Arduino.

Pajkanovic and Dokic proposed a microcontroller system that enables an electric wheelchair to be controlled by the head motion. The system comprises electronic and mechanical components [11]. The accelerometer is used to collect the head motion data. The output of the digital system is connected to a mechanical actuator and it is used to position the wheelchair’s joystick based on the user’s command. The sensor data is processed by a novel algorithm; it is implemented within the microcontroller. The user’s head motion is translated into the wheelchair’s joystick position.

Nishimori et al. implemented a voice controlled wheelchair [12] which uses the voice command as the interface. A grammar-based recognition parser named “Julian” is used in this system. This is open-source software which is developed by Kyoto University and Nara Institute of Science and Technology. The voice commands consist of nine reaction commands and five verification commands. The reaction commands consist of five basic reaction commands and four short moving reaction commands. This system is based on the commercial electronic wheelchair Nissin Medical Industries co. NEO-PI. In this system, it consists of a headset microphone and a

laptop. The user can select either to control by voice or button. The control signal is sent to PIC from the laptop, and the PIC generates the motor control signal to drive the wheelchair. Meanwhile, in [13] introduce the voice recognition module with smart wheelchair and have same control movement with this project but in this paper recognize the commands through microphone. While in [14] smart wheelchair with voice recognition upgrade its capability with navigation maps and person present location with GPRS and GSM system.

In this paper will discuss, a smart wheelchair is developed to help an elderly or physically disabled person (user) to move from one place to another independently. An android application is developed and installed in the android smartphone. It consists of two controlled modes, the first mode is the touch mode and the second mode is the voice recognition mode. An elderly or physically challenged person can direct the direction and movement of the wheelchair with the help of the android smartphone in four different directions, left, right, forward, reverse and stop. The wheelchair will move according to the command given by the user.

2. Methodology

For this part will be divided into two main part, software and hardware development:

2.1. Development of android application (MIT app inventor)

MIT App Inventor is an application to transform a complex language of text-based coding into a visual and drag-and-drop building block. A command is a block that specifies an action to be performed on the phone. Some commands require one or more input values to completely specify their action. In Fig. 1 and Fig. 2 represent voice recognition mode and touch mode block diagram using Android application. The best part for using android is an open-source electronics platform and it is able to read an input and convert it into an output. Arduino is cheaper compared to other micro-controllers and it can run on windows, Macintosh OSX and Linux operating system.

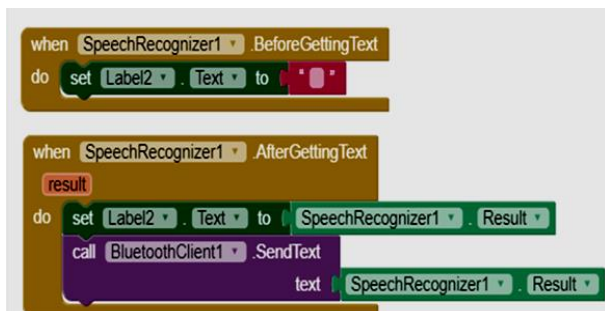

Fig. 1: The Design Block Diagram for the Voice Recognition Mode.

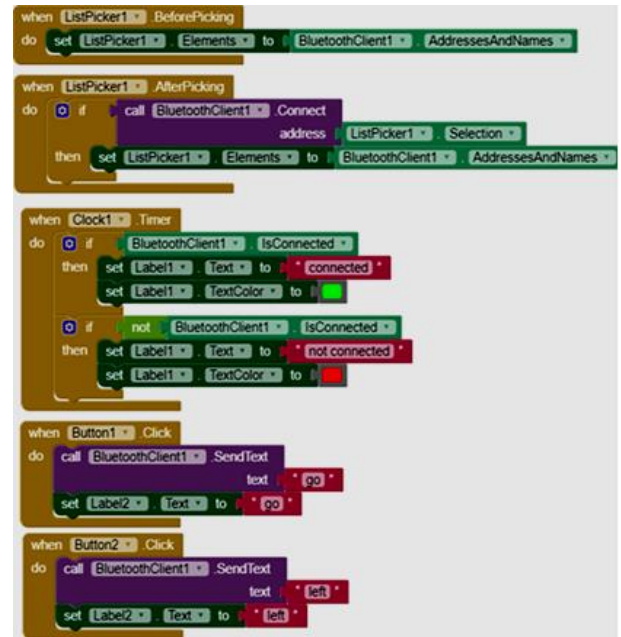

Fig. 2: The Design Block Diagram for the Touch Mode.

2.2. Hardware Implementation

The system consists of six main components, two motor drivers, two scooter DC motor, a Bluetooth module, a microcontroller, a power supply and software. Both motors were mounted to both wheels and the control box is placed between them a 24V power supply is placed in front of the control box shows in Fig. 3.

Table 1: The Table of Components

No.	Components	Description
1.	Motor driver	MD30C
2.	Scooter DC motor	350W,24V,2600rpm
3.	Bluetooth module	HC-05
4.	Microcontroller	AVR(Arduino Uno)
5.	Power supply	24V/7.0Ah lead acid and 9V battery
6.	Software used	Arduino and MIT app inventor

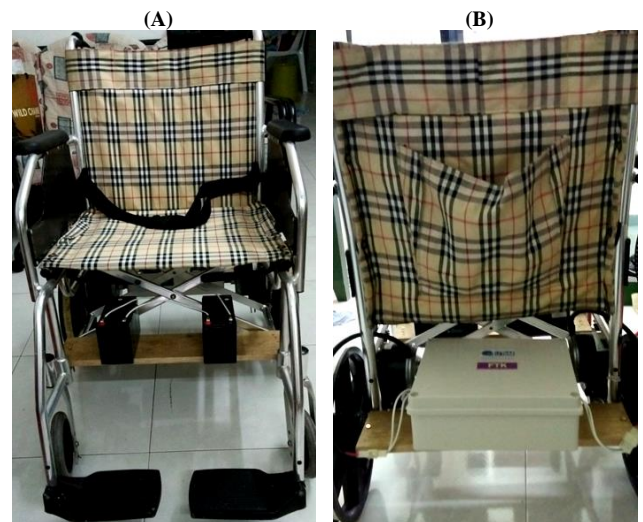

Fig. 3: (A) Front View and (B) Rear View of the Wheelchair.

The control box shows in Fig. 4 consists of Arduino Uno, an MD30C motor driver and a Bluetooth module. Arduino Uno is used to control the motor driver. Its only digital output pin is used.



Fig. 4: The Control Box.

Arduino Uno is a microcontroller board based on the ATmega328. The architecture of Arduino microcontroller is the AVR and the operating voltage is 5V. The HC-05 Bluetooth module is designed for the transparent wireless serial connection setup. It has only 4 pins which are 5V, GND, TX and RX. The 5V and GND pin are used for power purpose and the TX and RX pin are used for a serial interface. The pin configurations of 6 to 9 are used to control the motor driver. Pin 6 and 7 are connected to motor driver 1 and pin 8 and 9 are connected to motor driver 2. The pin configurations of 10 and 11 are used for serial interfacing with the TX and RX. Arduino Uno will decode and process the data delivered from the Bluetooth. Then, it will pass the signal to the motor driver. The motor driver will direct the wheelchair according to the command given.

2.3. Work flow

The power supply is used to supply electrical energy to the Bluetooth module, Arduino Uno, motor driver and motor. The user can control the movement of the wheelchair by giving command via the android smartphone. The user can select one of the modes to give command.

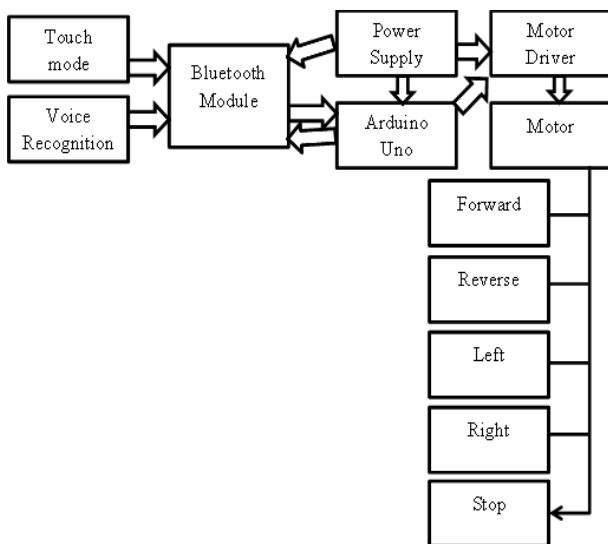

Fig. 5: Smart Wheelchair Work-Flow Process.

For the voice recognition mode in Fig 6, the user must turn on the Bluetooth on the android smartphone, and then select the correct paired device to connect. When the Bluetooth is connected, the user can start to give command. For the touch mode in Fig 7, in the same way as the voice recognition mode, the user needs to connect to Bluetooth and start giving command by selecting the direction specified within the four quadrants on the screen.

The command given by the user is transmitted to Arduino Uno via the Bluetooth module. The Bluetooth will first convert the commands given by the user in a binary format and send to Arduino Uno. Next, the Arduino Uno will read and execute the command and lastly send the digital values to the motor driver device. The motor driver will direct the wheelchair according to the command given.

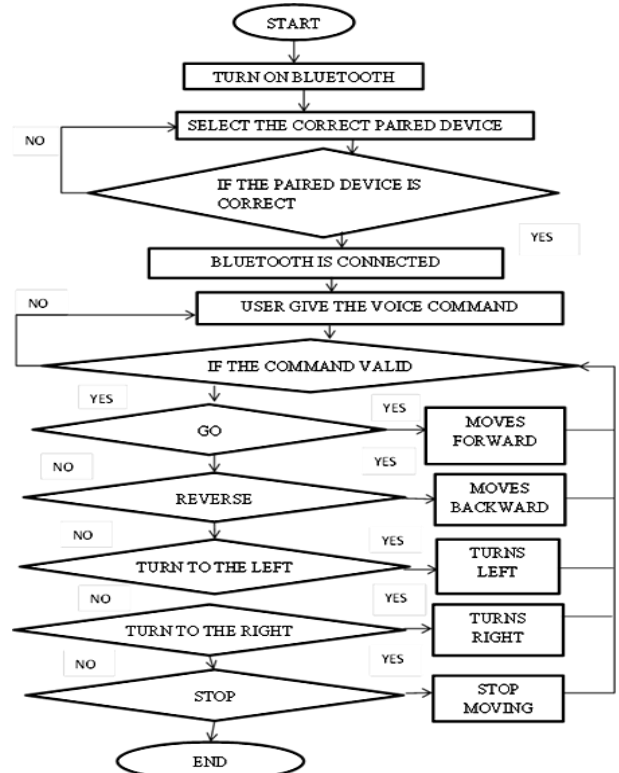

Fig. 6: Flow-Chart of Voice Recognition Mode.

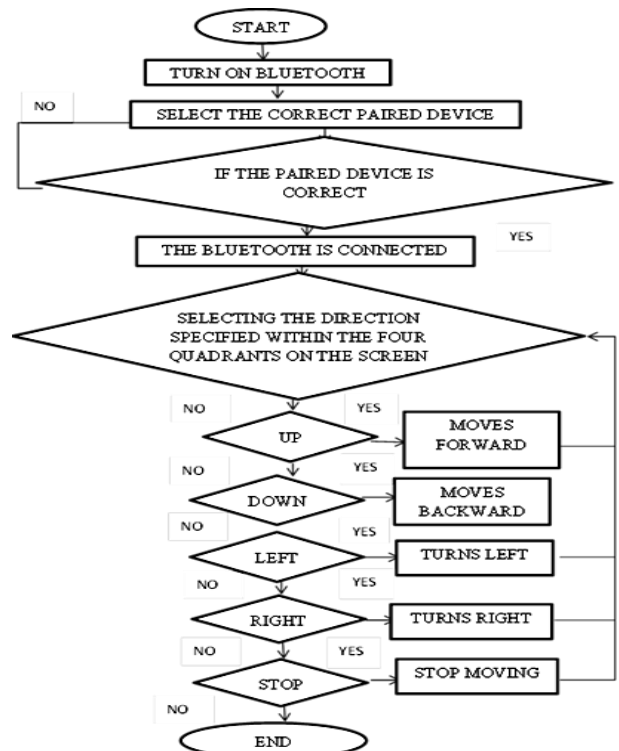

Fig. 7: Flow-Chart for Touch Mode.

1. Results and discussion

For the voice recognition mode and touch mode, the wheelchair will move according to the command given. There are four possible directions of movements: forward, backward, left, right.

3.1. The voice recognition mode

In order to test the effectiveness of this system, a few experiments were carried out to analyse the consistency of the voice recognition mode in different conditions and voice inputs. The first experiment was carried out in two different areas, silent area and noisy area. The second experiment was tested by 10 different speakers in different environments. Each speaker was asked to give 9 commands and the number of times the system response correctly will give the result. For each of the tests, was repeated 10 times and results are averaged.

3.1.1. Voice recognition mode testing in two different environments

Two experiments were carried out in different areas, in a silent area and noisy area. The purposes of these experiments are to identify the consistency of the voice recognition mode in different areas that are embedded in an android phone. The percentage of consistency each command when spoken by the user is calculated by the following equation:

$$\text{percentage of consistency} = \frac{\text{Number of Recognised Words}}{\text{Number of Tested Words}} \times 100\% \tag{1}$$

Condition 1: Silent area

This experiment was carried out in a silent area. Five tests were performed on the circuit based on the commands listed on Table 2 below.

Table 2: The Voice Commands in the Silent Area

No. Testing	1	2	3	4	5	Total
Command						
Go	1	1	1	1	1	5
Back	1	1	1	0	1	4
Forward	0	1	0	1	1	3
Reverse	1	1	1	0	1	4
Left	0	1	0	1	1	3
Turn to the left	1	0	1	1	1	4
Right	1	1	1	1	0	4
Turn to the right	1	0	1	1	1	4
Stop	1	1	1	1	1	5

Based on the results above, there is a maximum of 2 wrong words in every five repeated words. There are 36 over 45 commands recognised by the voice recognition mode. The percentage of consistency of the circuit in the silent area is 80%.

Condition 2: Noisy area

This experiment was carried out in a noisy area. Five tests were performed on the circuit based on the commands listed in Table 3 below.

Table 3: The Voice Commands in the Silent Area

No. Testing	1	2	3	4	5	Total
command						
Go	1	0	1	1	0	3
Back	0	1	0	0	1	2
Forward	1	1	0	0	1	3
Reverse	0	0	1	1	0	2
Left	1	0	1	0	1	3
Turn to the left	1	0	1	0	1	3
Turn to the right	1	1	0	0	0	2
Right	0	1	1	0	1	3
Stop	1	1	0	1	1	4

From above results shows there is a maximum of 3 wrong words in every five repeated words. There are 25 over 45 commands recognised by the voice recognition mode. The percentage of consistency of the circuit in the noisy area is 55.6%.

From both results it can see that the consistency of the voice recognition mode in the silent area is higher than the noisy area. This means that the voice recognition mode is less efficient in the noisy area.

3.1.2. Voice recognition mode tested by ten random speakers in two different environments

For this testing 10 random speakers were asked to give the voice command. Each person is required to give 9 commands; “go”, “back”, “forward”, “reverse”, “left”, “turn to the left”, “right”, “turn to the right” and “stop”.

Condition 1: Silent area

Table 4: The Test Results of Ten Random Speakers in the Silent Area

	F	F	F	F	F	M	M	M	M	M	Total
Go	0	1	0	1	1	1	0	0	1	1	6
Back	1	1	1	1	1	0	1	1	1	1	9
Forward	1	1	0	1	1	1	1	0	0	1	7
Reverse	1	1	1	0	1	1	0	1	0	0	6
Left	0	0	1	1	0	1	1	1	0	1	6
Turn to the left	1	0	1	0	1	1	0	1	1	0	6
Right	0	1	1	1	1	0	1	1	0	1	7
Turn to the right	1	1	0	1	1	1	1	1	1	1	9
Stop	1	1	1	1	1	1	1	0	1	0	8
Total	6	7	6	7	8	7	6	6	5	6	90

There is a maximum of 3 wrong words in every 10 speakers’ repeated words. The percentage of the consistency could be higher if the test is done with good pronunciations and the words are spoken at a moderate pace. This test proved that there is no major difference in the consistency and efficiency of the system whether the speaker is male or female.

Condition 2: Noisy area

Table 5: The Test Results of Ten Random Speakers in the Noisy Area

	F	F	F	F	F	M	M	M	M	M	Total
Go	1	1	0	1	1	1	0	0	1	0	6
Back	0	1	0	1	0	1	0	0	0	1	4
Forward	0	0	1	0	0	0	1	1	0	0	3
Reverse	0	0	1	0	0	0	1	1	0	1	4
Left	0	0	1	0	0	0	1	0	1	0	3
Turn to the left	0	1	0	0	0	1	0	1	0	1	4
Right	1	0	0	0	0	0	1	0	1	0	3
Turn to the right	0	1	0	0	0	0	0	0	0	1	2
Stop	1	0	0	1	1	1	0	0	1	1	6
Total	3	4	3	3	2	4	4	3	4	5	90

There is a maximum of 7 wrong words in every 10 speaker’s repeated words. The percentage of the consistency could be higher if the test is conducted in a silent environment with good pronunciations and the words are spoken at a moderate pace. This test proved that there is an accuracy and efficiency of the system in a noisy area, however it is lower than the silent area.

3.2. The touch mode

After implementation of the smart wheelchair and its functionality was tested, it is found that the movement of the wheelchair using the touch mode revealed an excellent functionality in all directions. The android application is perfectly designed in order for the user to control the wheelchair.

Table 6: The Touch Mode by Button Command

Button command	Left wheel	Right wheel	Condition of the wheelchair
↑	Forward	Forward	Move forward
↓	Reverse	Reverse	Reverse
←	Stop	Forward	Turn to the left
→	Forward	Stop	Turn to the right
O	Stop	Stop	Stop

In order to test the efficiency of this system, the experiments were tested with an unload condition and 4 different weights of people with the same travelled distance.

Table 7: The Time Consumed for Different Load Conditions

Condition	Distance (m)	Time consumed (s)
unload	6	6.43
<40kg	6	7.00
40-45kg	6	7.20
45-50kg	6	7.30
>50kg	6	7.45

The time consumed for the wheelchair to move to the desired direction depends on the weight of the load. Thus, when the weight of the load increases, the time consumed for the wheelchair to move to the destination increases too. The load with more than 50kg has the highest time consumed and the wheelchair with no load has the lowest time consumed.

2. Conclusion

This wheelchair system is combination of mechanical, electrical and communications system. The main objectives were to design an android application that can direct the movement of a wheelchair, to develop the voice recognition mode and touch mode to help the elderly and physically disabled people to move their wheelchairs independently and to provide the elderly and physically disabled people with the ability to control the movement of the wheelchairs by using android smartphones. The system designed has undergone a few tests and successfully completed the basic performance. The objectives were achieved as the software and hardware implementation work well as expected. This system will help the elderly and physically disabled people to control wheelchairs with either a touch mode or voice recognition mode, therefore this success is to serve many people with disabilities. From the conducted research, it can be seen clearly that a mobile controlled wheelchair will have a bright future. It should be continued and developed in the future as it has a huge potential to improve its performance, reliability and safety. For future work, it is suggested to use a more powerful and lighter weight motor to support various weights of users. Besides, this system needs a lot of enhancements to improve its accuracy and functionality. This can be further improved by decreasing the time delay in voice mode and an obstacle sensor can be attached to avoid the collision of wheelchairs.

Acknowledgement

The authors would like to thank for the support given to this research by Ministry of Higher Education Malaysia and Universiti Teknikal Malaysia Melaka (UTeM) for support this under RAGS/1/2015/TK0/FTK/03/B00118 research grant.

References

- [1] Karen Rispin and Joy Wee, "Comparison between Performances of Three Types of Manual Wheelchairs Often Distributed In Low-Resource Settings", *Journal Disability and Rehabilitation: Assistive Technology*, Volume 10, Issue 4 (2015) pp. 316-322.
- [2] Rory A. Cooper and Arthur Jason De Luigi, "Adaptive Sports Technology and Biomechanics: Wheelchairs", *Original Research Paralympic Sports Medicine and Science*, Volume 6, Issue 8 (2014) pp. 31-39. <https://doi.org/10.1016/j.pmrj.2014.05.020>.
- [3] Sari Abdo Ali, Khalil Azha Mohd Annuar, Muhammad Fahmi Miskon, "Trajectory Planning For Exoskeleton Robot By Using Cubic And Quintic Polynomial Equation", *International Journal of Applied Engineering Research*, Volume 11, Issue 13, (2016) pp. 7943-7946.
- [4] S.A. Ali, K.A.M. Annuar, M.F. Miskon, M.H. Harun and M.F.M.A. Halim "Design and Control Leg-exo Robot for Rehabilitation Purpose", *Proceedings of Innovative Research and Industrial Dialogue 2016* (2017) pp. 13-14.
- [5] Liao Lu, Ping Yi Deng, Ying Wu, Jie Jun Bai, Yun Xiao Zhang, Yi Xiang, Liang Jin Shi and Rusen Yang, "Control System of Powered Wheelchairs Based on Tongue Motion Detection", *International Journal of Software Science and Computational Intelligence*, Volume 8, Issue 4, (2016) pp. 60-76. <https://doi.org/10.4018/IJSSCI.2016100104>.
- [6] M. F. Ruzaj, S. Neubert, N. Stoll and K. Thurow, "A speed compensation algorithm for a head tilts controller used for wheelchairs and rehabilitation applications," 2017 IEEE 15th International Symposium on Applied Machine Intelligence and Informatics (SAMI), Herlany, 2017, pp. 000497-000502. <https://doi.org/10.1109/SAMI.2017.7880360>.
- [7] Satish Kumar, Dheeraj, Neeraj, and Sandeep Kumar, "Design and Development of Head Motion Controlled Wheelchair", *International Journal of Advances in Engineering & Technology*, Vol. 8, Iss. 5, (Oct 2015) pp. 816-822.
- [8] Rana Mohammad Yousef, Omar Adwan, and Murad Abu-Leil. "An Enhanced Mobile Phone Dialler Application for Blind and Visually Impaired People", *International Journal of Engineering & Technology*, Volume 2, Issue 4, (2013) pp. 270-280. <https://doi.org/10.14419/ijet.v2i4.1101>.
- [9] Khalil Azha Mohd Annuar, Md Zin, Muhammad Haikal, Mohamad Haniff Harun, Mohd Ab Halim, Mohd Firdaus, Arman Hadi Azahar, "Design and Development of Search and Rescue Robot" *International Journal of Mechanical & Mechatronics Engineering*, Volume 16, No. 02 (2016) pp. 36-41.
- [10] Cerejo, R., Correia, V. & Pereira, N., "Eye Controlled Wheelchair Based On Arduino Circuit", 3(6), (2015) pp.94-98.
- [11] Nishimori, M., Saitoh, T. & Konishi, R., "Voice Controlled Intelligent Wheelchair" *SICE Annual Conference 2007*, (2007) pp.336-340.
- [12] Pajkanovic, A. & Dokic, B., "Wheelchair Control by Head Motion", *Serbian Journal of Electrical Engineering*, 10(1), (2013) pp.135-151. <https://doi.org/10.2298/SJEE1301135P>.
- [13] Srishti, Prateeksha Jain, Shalu, Swati Singh., " Design and Development of Smart Wheelchair using Voice Recognition and Head Gesture Control System", *International Journal of Advanced Research in Electrical, Electronics and Instrumentation Engineering*, Vol. 4, Issue 5, (2015) pp.4790-4798.
- [14] C. Swaroop, S. Sabarinath, Mohammed Akramali, "Embedded Based Smart Wheel Chair with Voice Recognition", *Journal of Advanced Engineering Research*, Volume 2, Issue 2, 2015, pp.65-68.