



A Flash Flood Early Warning System: Algorithm and Architecture

Asokan Jayaram ^{#1}, Sanjoy Deb ^{*2}

[#] Assistant Professor, Paavai Engineering College, Namakkal, Tamilnadu, India

^{*} Corresponding author E-mail: jasokan77@gmail.com

Abstract

The flash flood is one of the most lethal forms of natural hazards and every year damages colossal properties and causes human deaths. An early flash flood detection and warning system can provide an effective solution to this problem by giving people sufficient time to evacuate and protect their life and property. On the other hand, presently Wireless Sensor Network (WSN) based systems are widely used as an effective warning system against different hazard scenarios e.g.; fire, tsunami etc. Such WSN based system can also be design to generate an early warning against the Flash Flood and such system is high on demand. This system will be having sensor nodes, processing unit and warning unit etc, for successful prediction and warning generation. Under present work, a WSN based indigenously designed, low cost, accurate and automated Flash Flood Early Warning (FFEW) system has been proposed and studied with technical details. The algorithm of the central processing unit/block for the proposed system has been implemented with MATLAB Simulink and also hardware implemented with PIC microcontroller. Experimental outcomes show that such system will be very much effective to generate a valuable early warning against the devastating flash floods and will be helpful in preventing huge collateral damage.

Keywords: Flash Flood, WSN, Microcontroller, RF Transmitter-Receiver, Rain Gauge sensor

1. Introduction

According to World Meteorological Organization (WMO), a flash flood is generally defined as a rapid onset flood of short duration with a relatively high peak discharge [1]. The flash floods are one of the most lethal form of natural hazard (based upon the ratio of fatalities to people affected), and cause millions of dollars in property damage every year [1]. Flash floods can be triggered by a variety of events including intense rainfall, failure of a natural (e.g., glacial lake debris) or manmade (e.g., dam, levee) structure that is impounding water, or the sudden impoundment of water upstream of a river ice jam [1]. Along with the whole world India is also vastly affected by such catastrophic events in long and recent past [2]. In recent time, Flash floods has killed 250 people on October 8 2009 at Andhra Pradesh, 103 people on 6th August 2010 at Ladakh, 31 people on 3rd August 2012 at Uttarkashi, 24 people on 23rd September at Northern Sikkim (death) and left several people injured as well as coasted huge property loss [2]. Few years back on 18th June, 2013 the biggest flash flood event has occurred in Indian history, at Kedarnath (Uttarakhand), which has killed more than 10,000 people according to the Govt. report [2]. Flash flood, its deadly consequences and relevant safety measures are the burning issues to the researchers, scientists, engineers and domestic and international policy makers throughout the world [3-5]. Successful prediction of flash flood and generating an effective early warning, are under active research especially in remote and inhospitable forest mountain regions where flash floods are highly unpredictable and deadly [6]. Design and successful implementation of such forecasting and warning system can protect life and property loss [7-8]. Such issues can be significantly addressed with the design and implementation of fully au-

tomated Wireless Sensor Network system based Flash Flood Early Warning (FFEW) system. Now-a-days Wireless Sensor Networks (WSN) are vastly implemented as healthcare, defence and security, environmental monitoring and building/structural health monitoring system [9]. Such type of WSN based indigenously designed, low cost, accurate and automated FFEW system is highly on demand in India as well as around the world. Present work has been devoted to develop an effective architectural algorithm for such FFEW system. Along with the algorithm, the technical specifications and functionality of the different blocks of the proposed system has been discussed elaborately. Under present study, the core algorithm of FFEW system has been simulated with MATLAB Simulink and simulation outcome has been analysed. Being hindered by the financial issue, only the central processor block of the proposed system, has been programmed, designed and implemented with PIC microcontroller. Using the designed software and hardware model, proposed FFEWS system algorithm has been verified experimentally.

2. System Architecture

Under the architecture of the proposed WSN system, a group of end point sensor nodes which will serve as primary nodes. The primary nodes will be connected to a particular number of secondary nodes and those secondary nodes will be connected to a base station. Number of end point sensor nodes or primary node and gate way nodes or secondary node can be varied based on the range of the application but there will be a single base station in a particular locality which will generate some warning signal as well as can be linked with concerned public office through GPS [9].

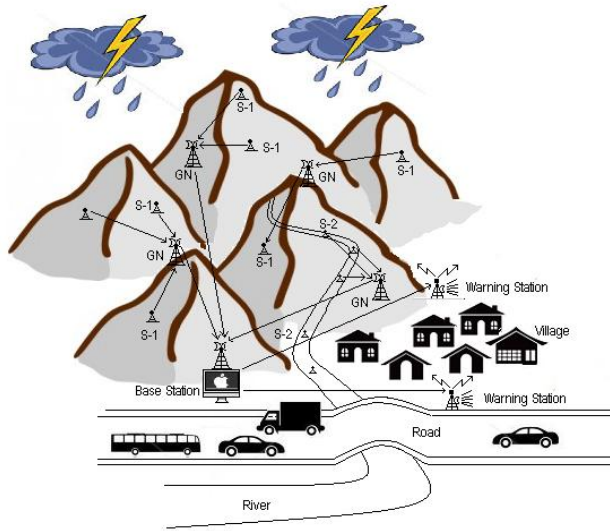

Fig. 1: A picture showing the functioning of an FFEW system. Sensors; S1: Rain-gauge or some similar sensors, S2: Water level/flow measuring sensor, GN: Gate-way-Node

The whole FFEW system can be divided into different blocks and sub blocks as explained below.

A. Primary Block

This block will consist mainly three sub-blocks e.g.; sensor, transmitter and power source. Sensor is a very important issue related with the proposed project since it needs to be small, reliable, highly sensitive, cost effective and easily installable. Under the proposed project rain gauge or similar types of sensor (S1) will continuously monitor rain fall in the mountain regions. For the proposed system RG-11 Rain Sensor can be used which includes a DIP switch that allows it to be set up for the mode of operation that best matches the application. It’s robust, easy to use and it is remarkably inexpensive which make it useful for the proposed system. Similarly, another type of sensor (S2) can be mounted on mountain river bed to measure sudden increase in water level and flow which can be considered as an indication of flash flood. Transmitter part will be as simple as possible which will generate a signal to be transmitted to the secondary node. For less complexity it will be a unidirectional unit.

B. Secondary Block

This block will be having mainly three sub blocks e.g.; a transmitter and a receiver with bidirectional communication ability and a signal processor unit which will filter the incoming signal for a specific frequency and amplitude.

C. Central Processing Block

The Central Processing Block (CPB) or base station will be having three sub blocks e.g.; a core processor, transmitter-receiver block and a warning signal generating block. The CPB will be mounted in some secure place and will be having a GPS transmitter and a local warning system (an audio visual unit).

3. CENTRAL PROCESSING BLOCK

The functioning algorithm of CPB has been both software and hardware implemented with MATLAB Simulink and PIC Micro-controller respectively.

A. CPB Simulation Model

To establish the algorithm of the proposed system, a scalable mathematical relationship has to be formed between input param-

eters and Output Warning Signal (OWS). Under present analysis input parameters have been considered are Rain Time (RT), Rain Intensity (RI), Local Geography (LG) and Flood History (FH) of that location [3]. Along with the rain time and intensity the favorable geography and history of flash flood at a particular location can also play a dominating role in flash flood prediction [5]. First two parameters will be the outcome of the sensor S1 and second two will be coming from the saved data of CPB memory. Every parameter will be assigned a weight in percentage based on its predicted impact on OWS generation. The considered weight for each parameters for OWS calculation are; RT=50%, RL=30%, LG and FH are 10%, respectively. Again, each parameter will be categorized into three sub-parameters based on its value. For, RT, long time rain detection will be defined as RTH (Rain Time High) and will be having 50% weight of total RT, medium rain time will be defined as RTM (Rain Time Medium) with weight percentage 30 of total RT and low rain time will be defined as RTL (Rain Time Low) with weight percentage 20 of total RT.

Similarly for other parameters corresponding sub-parameters will be categorized as;

RI: RIH (Rain Intensity High) 50%, RIM (Rain Intensity Medium) 30%, RIL (Rain Intensity Low) 20% of total RI respectively.

LG: ULG (Unsafe Local Geography) 50%, MLG (Moderate Local Geography) 30%, SLG (Safe Local Geography) 20% of total LG respectively.

FH: FFH (Frequent Flood History) 50%, MFH (Medium Flood History) 30%, LFH (Less Flood History) 20% of total FH respectively. At any particular time, only one sub-parameter will be active and corresponding parameter value will be calculated based on the weight assigned to that particular sub-parameter and overall OWS will be calculated based on weight assigned to all the parameters. The formulated equation of input parameters and OWS will be

$$OWS = (RTH \text{ or } RTM \text{ or } RTL) * \frac{50}{100} + (RIH \text{ or } RIM \text{ or } RIL) * \frac{30}{100} + (ULG \text{ or } MLG \text{ or } SLG) * \frac{10}{100} + (FFH \text{ or } MFH \text{ or } LFH) * \frac{10}{100} \tag{1}$$

Like input parameters, OWS will be also categorized High (OWSH), Medium (OWSM) or Low (OWSL) based output warning signal strength

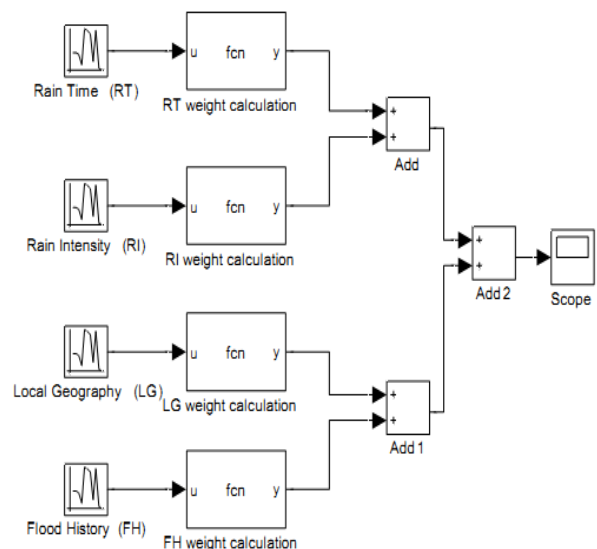

Fig. 2: MATLAB Simulink model of proposed FFWS algorithm

All though, the number of parameters and their actual impact on overall output signal generation is a subject of practical field study but those adjustments can be incorporated effectively with little or moderate modification of proposed simulation model.



Fig. 3: Hardware implementation of FFWS CPB algorithm

B. CPB Simulation Model

The algorithm for FFWS CPB has been hardware implemented with four switches (considered as sensor S1), LEDs, LCD, Buzzer and microcontroller (PIC16F877A) etc. as shown in Fig. 3. To maintain the simplicity, the present system hardware has been designed in such a way that at a time only one parameter and its impact on OWS can be analyzed. When RT is considered as input: if more than 3 switches are ON then RT is considered as RTH, if 2 or more than 2 switches are ON then RT is RTM and if 1 or no switch is ON then RT is RTL, respectively. The red, green and blue LEDs have been used to implicate output conditions OWSH, OWSM and OWSL, respectively and the output signal will be also displayed on LCD screen. The buzzer will create warning sound with red LED and “Output Warning Signal High” on the LCD display at OWSH condition. The whole code for the algorithm has been written with “micro-c” and successfully burned in PIC microcontroller.

4. RESULT & DISCUSSION

Under the present study, the algorithm for the CPB of the proposed system has been developed and implemented with MATLAB Simulink and PIC microcontroller. For simplicity inputs from the sensor S1 has been considered only. In simulation model, input parameters are generated randomly and how different combinations of input parameters will generate subsequent OWS are shown with time scale in Fig. 4 to Fig. 8.

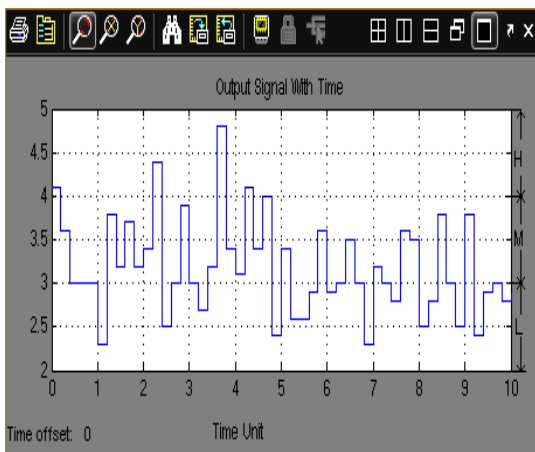

Fig. 4: OWS with time. High, Medium and Low ranges have been shown in a scale of maximum 5 from 0

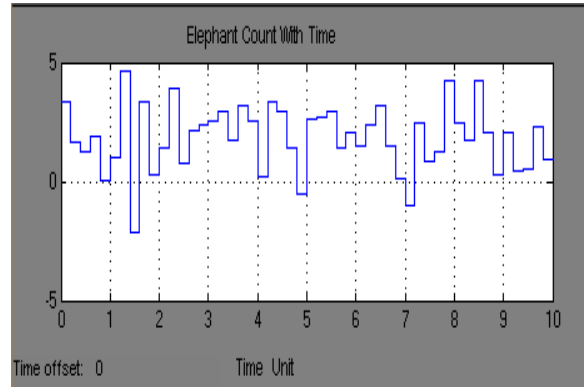

Fig. 5: Randomly generated RT values with time. Value: 0-2 will be RTL, 2-3 will be RTM, 3-5 will be RTH. Any generated value of less than zero can be considered as noise for this and all the other graphs.

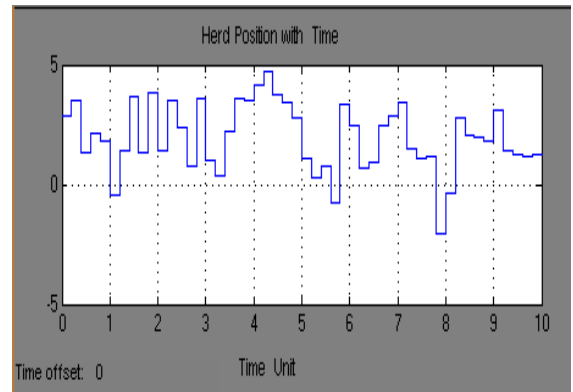

Fig. 6: Randomly generated RI values with time. Value: 0-2 will be RIL, 2-3 will be RIM, 3-5 will be RIH.

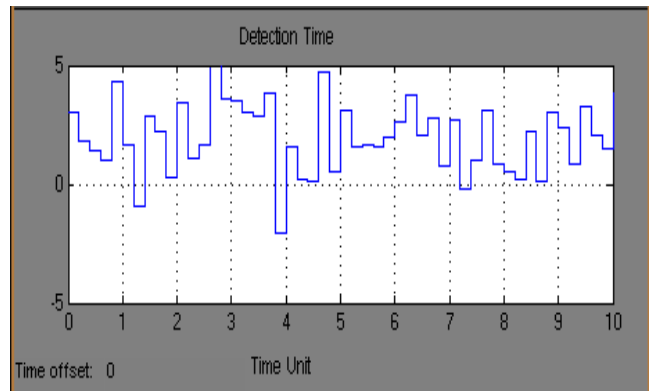

Fig. 7: Randomly generated LG values with time. Value: 0-2 will be SLG, 2-3 will be MLG, and 3-5 will be ULG.

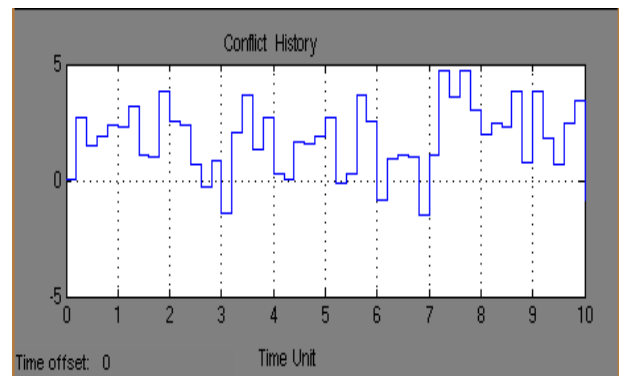

Fig. 8: Randomly generated FH values with time. Value: 0-2 will be LFH, 2-3 will be MFH, 3-5 will be FFH.

In the presented results, all the weight percentage of input parameters and OWS have been converted in a scale of 0 to 5. Input pa-

rameters are randomly generated from -5 to +5 with a dc offset bias value +2.5. Randomly generated negative value for any input parameter can be considered as a representation of physical noise. When OWS value is less than 3 it will be considered as OWSL (e.g.; time range 6.8 to 7) and if between range 3 to 4 it will be considered OWSM (e.g., time range 1.2 to 1.4) and more than 4 will be OWSH (e.g., the time range 3.6 to 3.8) as shown in the Fig. 4 and corresponding input parameters can be visible from Fig. 5 to Fig. 8, respectively.

5. CONCLUSION

Under present study, algorithm and architecture for an effective flash flood early warning system has been presented with technical details. Proposed FFEW system has been divided into different functional blocks and sub blocks. The software as well as the hardware for the central processing block, has been successfully designed and implemented with MATLAB Simulink and PIC microcontroller. The central processing block designed under present study can be successfully integrated with other peripheral blocks and sub blocks and the complete FFWE system can be effectively designed and implemented. Although there are considerable of scope for conceptual and technical improvements, the design and successful realization of such system will generate effective warning against the flash flood and thus will be able to save massive life and property loss throughout the world.

References

- [1] World Meteorological Organization (2013) The Global Climate 2001-2010: a decade of climate extremes [online] Available from: http://library.wmo.int/opac/index.php?lvl=notice_display&id=15110 [Accessed: 7th Jan 2014].
- [2] Indian Meteorological Department and National Disaster Management (2013) Year wise flood report [online] Available at: <http://www.imd.gov.in/> and <http://www.ndmindia.nic.in/> [Accessed: 10th Jan 2014].
- [3] University Corporation for Atmospheric Research, USA (Report under COMET Program), (2010) Flash Flood Early Warning System Reference Guide 2010, [Online] Available from: http://www.meted.ucar.edu/hazwarnsys/haz_flood.php [Accessed: 14th Jan 2014].
- [4] Drobot, S. et.al. (2007) Advances and challenges in flash flood warnings", *Environmental Hazards*, 7, p.173–178.
- [5] Abdelkhalek, A. (2011) Development of an early warning system for flash floods in wadi Watir – Sinai desert, PhD thesis at the Vrije Universiteit Brussel (VUB), Brussels, Belgium.
- [6] Cools, J. et.al. (2012) An early warning system for flash floods in hyper-arid Egypt, *Nat. Hazards Earth Syst. Sci.*, 12, p. 443-457.
- [7] Sene, K. (2013) *Flash Flood Forecasting and Warning*, Springer, 14-Dec-2012 - SCIENCE, p. 169-198.
- [8] Anurag, K. (2013) "Early flood warning system set up in Assam districts", (online) July 22, 2013 20:26 IST. Available from: www.rediff.com/news/report/early-flood-warning-system-set-up-in-assam-districts/20130722.html.
- [9] Dargie, W. & Poellabauer, C. (2010), *Fundamentals of Wireless Sensor Networks: Theory and Practice*, John Wiley & Sons, 05-Nov-2010, p. 20-60.
- [10] Adhami, K. (2012) *Programming PIC Microcontroller: Software for triggering circuit using PIC16F877A Microcontroller*, LAP LAMBERT Academic Publishing, Germany, p. 100-150.