

Enhanced Design of Fractional Order Induction Heating System

G.Padmanabha Sivakumar^{1*}, Umapathy Kannan²

¹Research Scholar, EIE Department - Sri Chandrasekharendra Saraswathi Viswa Maha Vidyalaya, Kanchipuram, India.

²Associate professor, Sri Chandrasekharendra Saraswathi Viswa Maha Vidyalaya, Kanchipuram, India

*Corresponding author E-mail: gpskumar@kanchiuniv.ac.in

Abstract

Class-F3 power amplifier system (CF3AS) is capable of generating fast heat for induction Heating or Dielectric. The main objective of research is to obtain a steady output voltage using the high frequency Class-F3 amplifier for an induction heating system. The entire work carried out using the CF3AS in closed loop. An uncontrolled rectifier is used to convert the AC (Alternating Current) supply into DC (Direct Current). The CF3AS converts the DC into high frequency AC. The FOPID controller is provided in the circuit to maintain the stable output voltage in the final stage. PI controlled CF3AS is used for comparing the results of FOPID based CF3AS.

Keywords: FOPID, Class-E, Class-F3, resonant inverter, Induction heating.

1. Introduction

RF Heating is one among the vast applications of power amplifiers. Power amplifiers are mostly used for the RF heating purpose. Power amplifiers are famous for their stability and their efficiency. Among all power amplifiers, Class-F3 amplifier is considered as the best to include in between a rectifier and induction heating (IH) system. The source current THD is minimized using an EMI filter in the input of CF3AS. The various applications and past developments of Induction heating were given by O.Lucia [1]. F.Caricchi proposed a new generator for induction heating gensets[2]. The gas industrial applications of induction heating were elaborately given by I.A.Makulov [3]. A half bridge resonant inverter was designed and explained by R.Phadungthin[4]. The IH system configuration methods and considerations while designing the systems were given by M.Adachi [5]. The Existing IH systems implemented using Class D/E amplifiers. The investigations of Class E inverter controlled system were provided by Arumugam [6]. A new topology of Class-E inverter for IH system is proposed by H.Sarango [7]. Induction cooking application using class-E amplifier is given by H. Mungikar [8]. Induction cooking with various loads is presented by P.Sharath kumar [9]. The circuit for IH system modelling and single ended resonant supply was given by J.M.Leisten[10]. Multi cycle modulation for induction cooking was given by O.Lucia[11]. A new topology for temperature control is provided by C. Ekkaravarodama [12]. A new working phenomenon for induction cooking system with mathematical model and design provided by M.Saoudi[13]. The characteristics of clamped voltage of Class E inverter based IH system by varying the pulse frequency modulation is given by N.Park [14]. New design of LLC inverter for induction heating is given by . M. Espi Huert[15]. The Class-E, Class-F amplifiers are focused in our research to improve the efficiency and other characteristics of an induction heating system. The previous work has not discussed about implementing FOPID controlled CF3A System. Current

work proposes FOPID controller for enhancement of dynamic response of CF3AS.

The work segregated into sections such as, the induction heating system explained in section-II. Results obtained from simulation are provided in section-III. Section-IV contains the analysis of time domain parameters and conclusion and scope given in the section-V

2. Induction Heating

2.1. Existing Induction Heating System

The Figure1 shows the existing system of induction heating. It is a process to heat the conducting material when it is kept in a continuously varying magnetic field. The losses generated in the process such as hysteretic loss and eddy current loss are considered as the primary reasons for induction heating. The electromagnetic waves enter into the material due to which it gets heated with no flame and contamination.

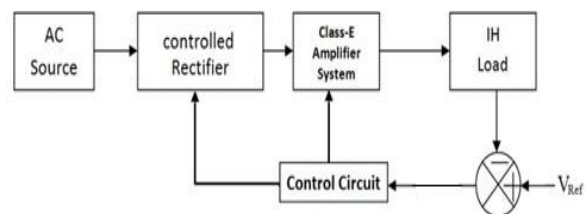

Fig. 1: Class-E inverter based IH system

2.2. Proposed IH System

The IH system implemented using Class-F3 amplifier is shown in the Figure 2. In this circuit the DC current will be obtained from

the output of uncontrolled rectifier. The low frequency AC is provided at the input of rectifier. The rectifier output is given to the Class-F3 amplifier and that turns into a high frequency alternating current (AC). The obtained voltage is compared with the fixed value of the voltage and the variation is provided to our FOPID based system. The error in the output is given to the pulse generator. Regulation of voltage is done by using FOPID controller.

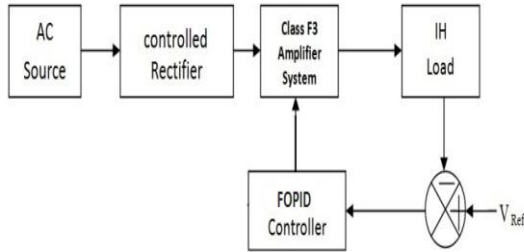

Fig.2: CF3AS with FOPID Controller

3. Simulation Results

PI controlled CF3AS is given in Figure 3.1 Output voltage is obtained from the PI controlled CF3AS and it is matched with the reference voltage provided to the system. The difference in the voltages is given to the PI controller. PI output has been provided to the comparators. These comparators compare the output of PI with a ramp wave to generate updated pulses for rectifier and class-F Amplifier. Input voltage that provided to the rectifier is given in Figure 3.2 and the peak value of the voltage is 32V. Voltage obtained at the output is provided in Figure 3.3 and the peak voltage value is 200 V. Value of current obtained at the output of CF3AS is shown in Figure 3.4 and the peak value of output current is 1.5 A. CF3AS output power is given in Figure 3.5 and measured value is 75W.

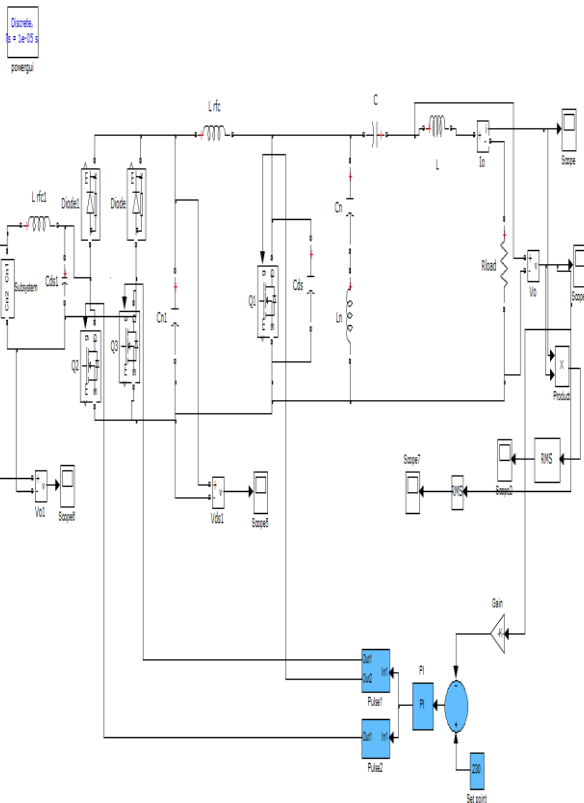

Fig 3.1: PI controlled closed loop CF3AS

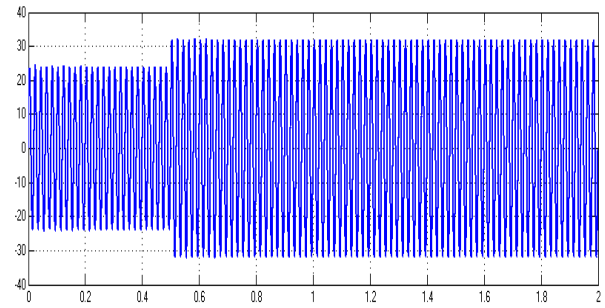

Fig 3.2: Applied voltage as input to Rectifier

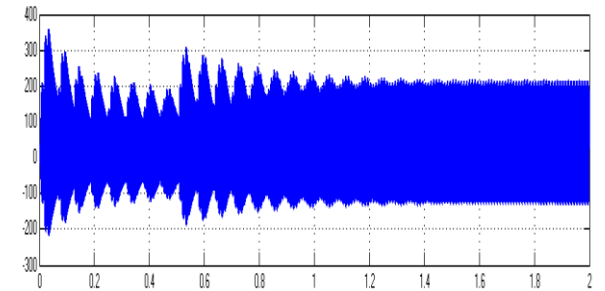

Fig 3.3: PI controlled CF3AS Output voltage

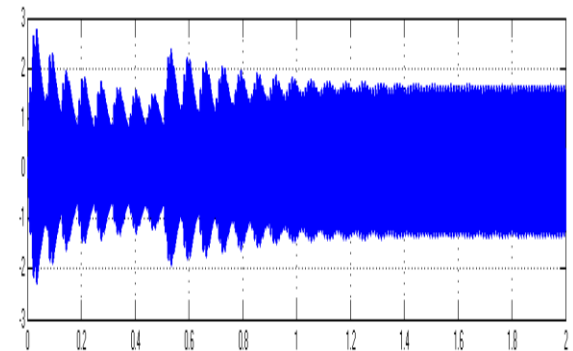

Fig 3.4: PI controlled CF3AS Output current

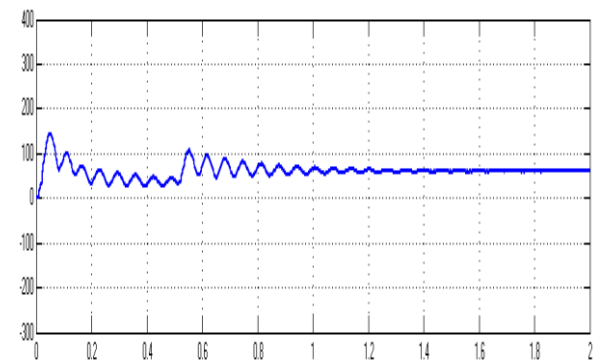

Fig 3.5: Power generated from PI controlled CF3AS

Closed loop CF3AS with FOPID controller is shown in Figure 3.6. The PI controller in previous system is replaced by FOPID controller. The input voltage applied to the CF3AS is given in Figure 3.7. The peak value of input is 30 V. Voltage obtained at the output is given in Figure 3.8 and the maximum peak obtained is 200V. Output current from the FOPID controlled CF3AS has given in Figure 3.9 and the peak value of current is 1A. The obtained power is given in Figure 3.10 and the value measured is 50W. FOPID controlled CF3AS is giving better results when compared with PI controlled CF3AS.

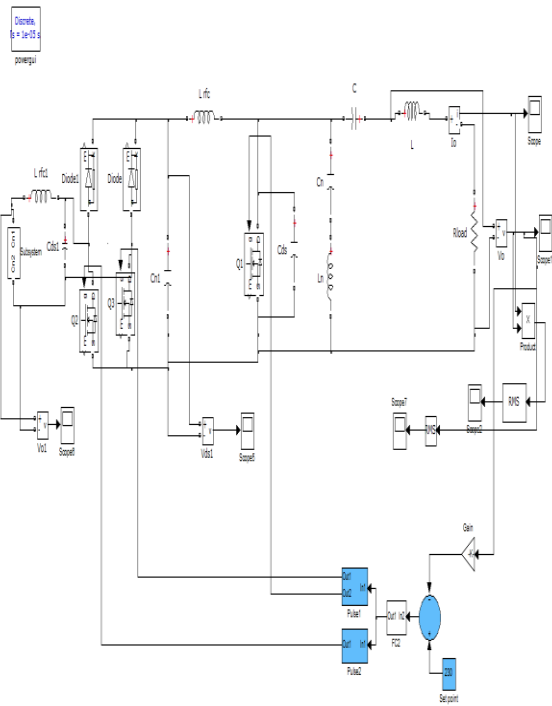

Fig 3.6: Closed loop CF3AS with FOPID controller

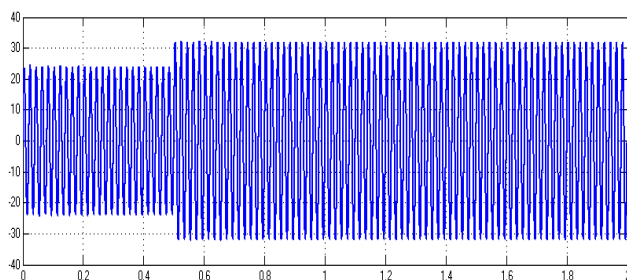

Fig 3.7: Applied voltage at the input of Rectifier

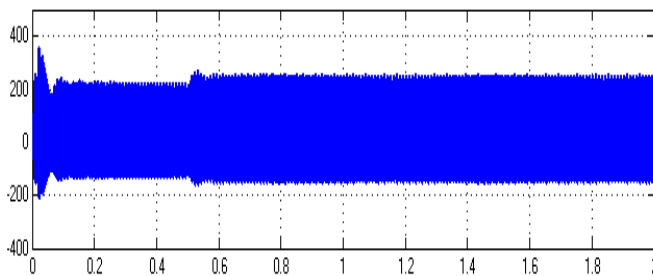

Fig 3.8: FOPID controlled CF3AS output voltage

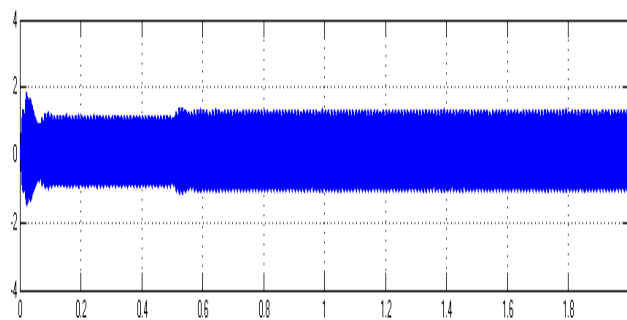

Fig 3.9: Output current from FOPID controlled CF3AS.

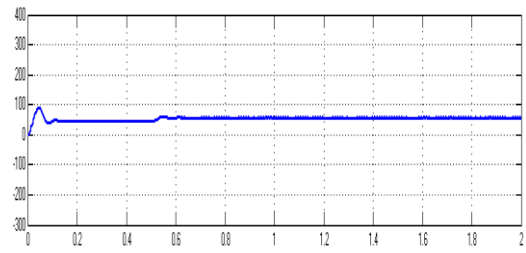

Fig 3.10: Power output of FOPID controlled CF3AS

4. Analysis of Time Domain Parameters

The simulation studies on FOPID controlled CF3A system is done for different reference values of voltage. The comparison of time domain parameters for reference values of 180V, 200V and 230V are presented in the Table-I, Table-II and Table- III respectively. The settling time reduces from 0.57s to 0.53s as the reference voltage value increases from 180V to 230V.

Table 1: Comparison of Time Domain Parameters ($V_{ref}=180$)

Type of Controller	T_r	T_s	T_p	E_{ss}
PI	0.08	1.5	0.61	2.7
FOPID	0.06	0.57	0.49	2.2

Table 2: Comparison of Time Domain Parameters ($V_{ref}=200$)

Type of Controller	T_r	T_s	T_p	E_{ss}
PI	0.07	1.3	0.60	2.6
FOPID	0.05	0.55	0.48	2.1

Table 3: Comparison of Time Domain Parameters ($V_{ref}=230$)

Type of Controller	T_r	T_s	T_p	E_{ss}
PI	0.06	1.2	0.59	2.4
FOPID	0.04	0.53	0.47	1.8

5. Conclusion

The closed loop CF3AS is successfully designed and the simulation results obtained using PI & FOPID Controllers. The simulation results for different values of reference values are presented. The steady state error with a reference value of 230V is 1.8V and the corresponding settling time is 0.53sec. The simulation values clearly show that the FOPID-CF3AS is better than that of PI-CF3AS in all parameters. The FOPID-CF3AS uses less switches and drivers in comparison with PI-CF3AS. This circuit consists of three capacitors which is considered as a disadvantage. This closed loop system needs two additional controlled switches. The present work discusses the comparison of PI controlled CF3AS and FOPID based CF3AS. The comparison between PI and proportional resonant controller is considered as future work.

References

- [1] O. Lucía, P. Maussion, E. J. Dede and J. M. Burdío, "Induction Heating Technology and Its Applications: Past Developments, Current Technology, and Future Challenges," in IEEE Transactions on Industrial Electronics, vol. 61, no. 5, pp. 2509-2520, May 2014.
- [2] F. Caricchi, F. Maradei, G. De Donato, F. G. Capponi, "Axial-flux permanent-magnet generator for induction heating gensets", IEEE Trans. Ind. Electron., vol. 57, no. 1, pp. 128-137, Jan. 2010.
- [3] I. A. Makulov and A. E. Alitdinov, "The equipment and application features of induction heating in oil and gas industry," 2017 International Conference on Industrial Engineering, Applications and Manufacturing (ICIEAM), St. Petersburg, 2017, pp. 1-4.
- [4] R. Phadunghin and J. Haema, "Application study on induction heating using half bridge LLC resonant inverter," 2017 12th IEEE Conference on Industrial Electronics and Applications (ICIEA), Siam Reap, 2017, pp. 1582-1585.

- [5] M. Adachi and H. Yonemori, "Considerations of configurations on induction heating type indirect heating system," 2014 IEEE Region 10 Humanitarian Technology Conference (R10 HTC), Chennai, 2014, pp. 88-93.
- [6] S.Arumugam "Experimental Studies on Class E Inverter based Induction Heater" International Journal of Computer Theory and Engineering, Vol. 3, No. 2, April 2011 ISSN: 1793-8201.
- [7] H. Sarnago, A. Mediano, D. Palacios and A. Santolaria, "A novel class E RF self-oscillating topology for induction heating applications," Proceedings of the 2011 14th European Conference on Power Electronics and Applications, Birmingham, 2011, pp. 1-6.
- [8] H. Mungikar and S. Jape, "Trends in energy conservation technology: Temperature control of induction cooking application using class E resonant inverter," 2015 International Conference on Energy Systems and Applications, Pune, 2015, pp. 214-219.
- [9] P. Sharath Kumar, N. Vishwanathan, B. K. Murthy and D. Vijaya Bhaskar, "Class-D/E resonant inverter for multiple-load domestic induction cooking appliances," 2014 IEEE 6th India International Conference on Power Electronics (IICPE), Kurukshetra, 2014, pp. 1-6.
- [10] J. M. Leisten, A. K. Lefedjiev and L. Hobson, "Single ended resonant power supply for induction heating," in Electronics Letters, vol. 26, no. 12, pp. 814-816, 7 June 1990.
- [11] H. Sarnago, O. Lucía, A. Mediano and J. M. Burdío, "A Class-E Direct AC-AC Converter With Multicycle Modulation for Induction Heating Systems," in IEEE Transactions on Industrial Electronics, vol. 61, no. 5, pp. 2521-2530, May 2014. B.Ramkumar, H. M.Kittur, and P. M. Kannan, "ASIC Implementation of Modified Faster Carry Save Adder," Eur.J.Sci.Res., 2010, vol.42, no.1, pp.53-58.
- [12] C. Ekkaravarodome, P. Charoenwiangnuea and K. Jirasereamornkul, "The simple temperature control for induction cooker based on class-E resonant inverter," 2013 10th International Conference on Electrical Engineering/Electronics, Computer, Telecommunications and Information Technology, Krabi, 2013, pp. 1-6.
- [13] M. Saoudi, D. Puyal, H. Sarnago, D. Antón and A. Mediano, "A new multiple coils topology for domestic induction cooking system," Proceedings of the 2011 14th European Conference on Power Electronics and Applications, Birmingham, 2011, pp. 1-7.
- [14] N. - Park, D. Lee and D. Hyun, "Study on the new control scheme of class-E inverter for IH-jar application with clamped voltage characteristics using pulse frequency modulation," in IET Electric Power Applications, vol. 1, no. 3, pp. 433-438, May 2007.
- [15] J. M. Espi Huerta, E. J. Dede Garcia Santamaria, R. Garcia Gil, J. Castello Moreno, "Design of the L-LC resonant inverter for induction heating based on its equivalent SRI", IEEE Trans. Ind. Electron., vol. 54, no. 6, pp. 3178-3187, Dec. 2007.