



Synthesis of the Algorithm of Adaptive Compensation of Nonlinear Distortions for Informational Systems

Oleksandr Shefer^{1*}, Oleksandr Shulha¹, Nataliia Ichanska¹, Caterina Kozelkova²

¹Poltava National Technical Yuri Kondratyuk University, Ukraine

²Poltava National Technical Yuri Kondratyuk University, Ukraine

³Poltava National Technical Yuri Kondratyuk University, Ukraine

⁴State University of Telecommunication, Ukraine

*Corresponding author E-mail: avs075@ukr.net

Abstract

An adaptive method of compensation of non-linear distortions was created in informational systems on the basis of usage the synthesized non-linear adaptive compensators for the expansion of a linear dynamic diapason of radio receiving devices that differs from the well-known ones, because it doesn't lead to reduction of reliability of telecommunication systems both in apparatus and in functional meaning that allowed to increase the quality of their functioning. The usage of non-linear adaptive compensators allows getting the necessary meanings of parameters and the methods of connection of devices that are set to depress the non-linear distortions in those mentioned systems that will allow increasing the reliability of functioning of informational systems in 12% in general.

Keywords: telecommunication system, dynamic diapason, non-linear adaptive compensation, noise immunity, non-linear dispatching function.

1. Introduction

The opportunities of practical realisation of potential characteristics of telecommunication systems are substantially limited by a number of internal (relatively low reliability of equipment and non-stability of dynamic diapason of receiving devices of telecommunication systems) and external factors (non-stationary of conditions of expansion of radio waves in time, deviation of a satellite – a carrier of telecommunication systems from uniform rectilinear motion, the intrusion of obstacles on the entrance of radio receiving devices of telecommunication systems). This, first of all, explains available at present time lagging of real indices of quality of telecommunication systems from their potential opportunities.

The weightiest factor that has an essential influence on the quality of functioning of telecommunication systems and their noise-immunity in condition of their radio electronic counteraction is a limitedness of dynamic diapason of real radio receiving devices as a consequence of non-linearity of their amplitude characteristics [1]. An effect of limitedness of dynamic diapason of radio receiving devices exceeds the activity of other factors in a raw of occasions. Especially it is seen during the influence of obstacles of various kinds on these radio receiving devices [2].

The practical realization of potential opportunities of telecommunication systems that are currently rapidly higher than their real accessible technical characteristics – is one of the main tasks of modern theory and practice of telecommunication systems.

It is needed to pay attention to the fact that non-linear processes in these real radio receiving devices are poorly learned and are the processes that cannot be easily removed. Furthermore, they have a substantial and many-sided influence on the quality of functioning of telecommunication systems and they are insufficiently accessible to severe and exact description and calculation in general. According to this, one of the most important and actual task that is

directed to increase the indices of quality of telecommunication systems is an expansion of dynamic diapason of their radio receiving devices.

It is important to mark that the increase of degree of linearity of an amplitude characteristic of radio electronic devices has extremely valuable meaning for the improvement of systems of automatic management. In particular, non-linearity of an amplitude characteristic of real radio electronic devices is the main obstacle on the way to creation of invariant systems of automatic management to the situation of presence of the obstacles.

However, well-known methods of expansion of linear dynamic diapason of radio receiving devices that includes, first of all, schemes of automatic regulation of strengthening, systems of adaptive regulation of sensitivity and also functional magnifiers with non-linear amplitude characteristic that are not completely suitable for increasing of the indices of quality of telecommunication systems in conditions of their radio electronic counteraction. These methods are grounded on non-linear concordance of dynamic diapason of re-entrant influences with the relatively narrow dynamic diapason of re-entrant signals. Consequently, their usage is accompanied with unalterable losses of a part of the information, reduction of the farness of activities of telecommunication systems and considerable amplitude and phase non-linear distortions. This leads to a considerable reduction of indices of quality of telecommunication systems (in a raw of occurrences their exactness is considerably lower than the exactness of telecommunication systems with linear radio receiving device due to the non-linearity of of an amplitude characteristic) and also to a considerable worsening of their noise immunity.

On the other hand, for the expansion of dynamic diapason of radio receiving devices of telecommunication systems methods that are grounded on the usage of schemes with the negative linear feedback are of the little use. This is conditioned with the reduction of a coefficient of transmission of radio receiving devices and consequently with the reduction of its sensitivity that leads to the reduc-

tion of farness of activities of telecommunication systems and the loss of the information about some weak radio local purposes. A group character of radio local signals considerably limits the opportunities of using this method that is grounded on a usage of a linear area of amplitude characteristic of radio electronic devices that is repeated and sequent in time. At the same time, optimal in a principle relation well-known linear methods of expansion of dynamic diapason of radio receiving devices that are grounded on the usage of the schemes of compensation, correction of non-linear distortions and also schemes with non-linear negative feedback that belongs to strict (that is to say, constantly turned on) methods of conservation, since the determinational filters with apriorily determined and constant in time parameters are used. In this connection, it is worthwhile mentioning that these methods are very sensitive to the inevitable errors of adjustment, apparatus realization and temporary non-stationarity of parameters of real radio devices. As a consequence, some well-known linear methods have insufficient exactness of depression of non-linear distortions and satisfactorily function only in a relatively narrow dynamic diapason of input influences and outside them they are not effective and can create some additional distortions.

Thus, a development of adaptive methods of expansion of a linear dynamic diapason of radio receiving devices of telecommunication systems that will be free from mentioned above drawbacks of well-known determined linear methods. Following all of this, it will be expedient and will have a lot of perspectives from the practical point of view to have a synthesis of adaptive schemes of compensation of non-linear distortions. This is conditioned with the fact that these schemes are the simplest and have the highest potential characteristics of exactness and they do not reduce the reliability of telecommunication systems since the put out of the action of a compensating filter does not lead to the refusal of radio receiving devices in contrast to the well-known adaptive compensators in the linear radio receiving devices that are conditionally called linear in this context.

It is obvious that the possibilities of increasing of indices of quality of telecommunication systems on the basis of synthesis of non-linear adaptive compensators can be successfully practically implemented only on the basis of an adequate conception and exact analysis of non-linear processes in radio receiving devices taking into consideration the frequently-dependent character of its non-linear amplitude characteristics. Furthermore, for the determination of scientifically-grounded demands to the width of a linear dynamic diapason of radio receiving devices in general as well as its separate cascades for the set conditions of usage of telecommunication systems it is needed to carry out a constructive investigation of the influence of non-linearity of amplitude characteristics of real multicascades radio receiving devices on the indices of quality of telecommunication systems. Herewith, the authenticity of finding out the optimal variants of construction of non-linear adaptive compensators and the ways of their connection to the radio receiving devices can be significantly determined with the possibility of demonstrative representation of the radio devices that were being investigated on different levels of their destalization and the convenience of a methodic of analysis for analytic investigations and numeral calculation the usage of computers.

Nowadays, the influence of non-linearity of amplitude characteristic of radio receiving devices on the quality of functioning of telecommunication systems is not sufficiently learned. In particular, a real opportunity of integrally evaluating the influence of non-linear processes in radio receiving devices directly on the indices of quality of telecommunication systems that are reasonable only for the relatively narrow raw comparing to some simple one-cascade inertialess radio receiving devices is absent. On the other hand, in a process of analysing the noise immunity of telecommunication systems the scientists suppose, as a rule, from the assumptions about linearity of radio receiving devices. However, non-linear influence of obstacles and a fight with them are really complicated in comparison with the methods of investigation and increasing of noise-immunity of linear radio receiving devices of

telecommunication system. Received at a current time results of the analysis of the influence of the obstacles on telecommunication systems with non-linear radio receiving devices have, as a rule, really limited sphere of utilization and a qualitative character, in general [1].

Till the present day, investigations were carried out with the conditions of making really serious assumptions about simplification and they were not fully considering the specific peculiarities of origin of a mixture of radio local signals and obstacles in complicated multi-cascade radio receiving devices. The comparison of the results with the data of the analysis in a linear approaching that were received with the use of different methods in a row of occasions is really complicated. Some of the results are not sufficiently well-combined with the criteria of estimation of non-linear properties of radio receiving devices that were practically used. Consequently, the purpose of the article is to theoretically ground and create a method of increasing of quality of functioning of on-board radio local systems on the basis of improvement of adaptive methods of compensation of non-linear distortions.

2. Synthesis of an adaptive method of depression of non-linear distortions

Let's create some exact practical recommendations about the improvement of telecommunication systems on the basis of grounding and utilizing the adaptive ways of expansion of the linear dynamic diapason of their radio receiving devices. First of all, it is needed to carry out a synthesis of adaptive method of depression of non-linear distortions in a radio device. It is expedient to bring the conditions of this task to the accordance with the classic formulation of the task of an adaptive compensation of these obstacles in the linear radio receiving devices [2,3]. Well-known linear adaptive compensators can be characterized with the presence of the main and supportive entrances in which the mixture of a signal and an obstacle (correspondingly) come in [4]. With all of this, an obstacle in the main entrance is correlated only with the signal of an obstacle and it is not statistically connected (or poorly correlated) with the beneficial signal. To have an opportunity to immediately use the mathematic apparatus of the theory of adaptive systems [5] and with the purpose of formalization of a task of adaptive compensation of non-linear distortions, let's conditionally imagine the exit and the entrance of the monodimensional radio device as both the main and the supportive entrances of non-linear adaptive compensator, correspondingly.

All the methods mentioned above we will call the adaptive compensators of non-linear distortions [6]. Then, the general structural scheme of a monodimensional adaptive compensator of non-linear distortions (fig. 1) is equivalent to the classic linear adaptive compensator.

Actually, an input signal X is statistically connected only with the output signal Y and does not correlate with the internal noises of N of mentioned devices. It is obvious that a structure of an adaptive compensator of non-linear distortions can be fully determined with the method of description of the processes of radio devices [1] and with the algorithm of solving the task of adaptive compensation of non-linear distortions.

The output signal of a monodimensional non-linear radio device in an appearance of a tapered be the first m parts of Volterra series according to the work [7], can be showed as it is presented below:

$$Y(f_1, \dots, f_m) = Y_c(f_1, \dots, f_m) + N(f) = \sum_{k=1}^m H_k(f_1, \dots, f_k) \prod_{i=1}^k X(f_i) + N(f) \quad (1)$$

Then, according to method of the modified structural matrixes of systems [8] follows from a method of nonlinear entrance signals that for one-dimensional radio devices the general basic entrance of the adaptive compensator of nonlinear distortions separates in

the shaper of basic signals on m of basic entrances, each of which is influenced by a separate basic signal of a look [8]

$$X_k = X_k(f_1, \dots, f_k) \doteq \prod_{j=1}^k X(f_j), \quad k=1, 2, \dots, m. \quad (2)$$

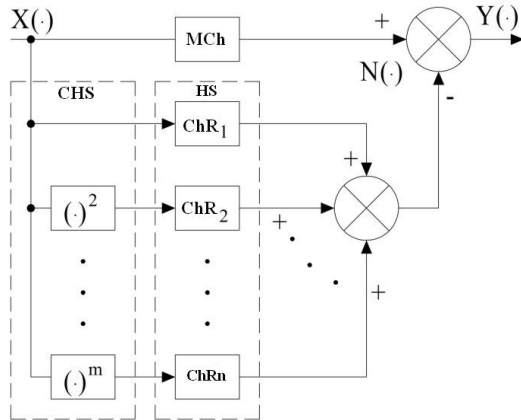

Fig.1: General structural diagram of a one-dimensional adaptive compensator of nonlinear distortion: MCh – main channel; CHS – reference driver; HS - reference scheme; ChRn - n-y the radio reception channel

It is possible to show that the basic signal of $X(\cdot)$ is rather strongly correlated only from k -go component about a day off of a signal of the radio device, that is $Y_k(f_1, \dots, f_m) = H_k(f_1, \dots, f_k) \prod_{i=1}^k X(f_i)$ and

is significantly interconnected, in statistical sense, with other components of an output signal of $Y(\cdot)$ ($k \neq j$) [9]. Therefore on an entrance of the adaptive compensator of nonlinear distortions there is full (to within an error of truncation of kernels of Voltaire the first m members) an oppression alarm components of an output signal of $Y(\cdot)$ while internal noise of $N(\cdot)$ take place without changes [10]. It should be noted that requirement of full statistical independence of signals is excessively rigid and unjustified [5]. As show results of experiments, adaptive compensators rather well work at strongly correlated signals generally and basic entrances [11]. If the component of n -go of an order of its output signal is useful reaction of the radio device, then removing from the adaptive compensator of nonlinear distortions the adaptive filter which the basic signal $X_{HS}(\cdot)$ of influences, at the exit of the adaptive compensator of nonlinear distortions, except internal noise of the radio device $N(\cdot)$, we have as well signal $Y_{HS}(\cdot)$. Physically it means suppression (compensation) of nonlinear distortions in this radio device. The structure of the adaptive compensator of nonlinear distortions can be significantly simplified if to remove also all adaptive filters, besides, on which the basic signal $X_l(\cdot)$ of arrives, where l - an order of the nonlinear distortions, most dangerous to this radio device [11].

It should be noted that the optimal solution of a problem of adaptive compensation, as a rule, cannot physically be realized as it assumes instant measurements and averagings on time of a significant amount of coefficients of autocorrelation of entrance influences of their mutual correlation with mistake signals (reference signals), and also addresses of a matrix high an order that is very difficult [12]. In this regard scientific and practical interest represents definition quasioptimum (that is approximately optimum) decisions which together with comparable simplicity are implemented physically, has bystry convergence in time to the optimal solution [6, 12].

Let's find a quasioptimum algorithm of the solution of a problem of adaptive compensation of nonlinear distortions. For this purpose we will present an output signal of the adaptive device which essentially is nonlinear system with non-stationary parameters in time, in the form of Voltaire's number truncated by the first m members parametrical [13, 14]

$$\sum_{k=1}^m W_k(f_1, \dots, f_k) \prod_{j=1}^k X(f_j) \doteq \sum_{k=1}^m W_k(t) X_k, \quad (3)$$

where $W_k(\cdot)$ - the parametrical nonlinear transfer k -go function of an order (the transfer k -go function of the adaptive filter). At the exit of the adaptive compensator of nonlinear distortions the mistake signal $\square(\cdot)$ which, in the assumption of a relative trifle of noise of $N(\cdot)$, is equal [6]

$$\varepsilon(t, f_1, f_2, \dots) \doteq \varepsilon(t) = Y - \sum_{k=1}^m W_k(t) X_k \cong Y_c - \sum_{k=1}^m W_k(t) X_k. \quad (4)$$

Now one of the most effective, from the practical point of view, in the theory of adaptive systems is the method of a minimum of an average square of a mistake [6]. This method can be considered as a special case of a gradient method of the fastest descent at assessment of a gradient of an average square of a mistake on its instant value [13]. It is possible to show that the specified assessment is sufficient and not displaced, and also significantly simplifies hardware realization of the synthesized adaptive device. Considering that all sizes in a formula (4) are complex, in the course of regulation of the transfer k -go function ($k = 1, 2, \dots, m$) the active filter in a complex differential form of record has the following appearance [6, 13]

$$\frac{dW_k(t, f_1, f_2, \dots, f_k)}{dt} \doteq \frac{dW_k(t)}{dt} = 2e_k \mu \varepsilon(t) X_k^{\otimes}, \quad (5)$$

where \square - a positive constant (coefficient of transfer of a chain of feedback) which defines stability and speed of reorganization of adaptive compensation of nonlinear distortions;

- e_k - proportionality coefficient, is in number equal to unit;
- the sign \otimes - designates in a complex interfaced size.

Generalizing the algorithm received above in case of multidimensional adaptive compensation of nonlinear distortions, it is possible to claim unambiguously that the structure of multidimensional adaptive compensation of nonlinear distortions and its shaper of basic signals unambiguously is defined by methods of nonlinear entrance signals and the modified stuktorny matrixes of systems. Similarly it is possible to find discrete option of a kvaziotimalny method of a minimum of an average square of an error of creation of adaptive compensation of nonlinear distortions which complex form of record looks [6]

$$W_k(j+1, z_1, \dots, z_k) = W_k(j, z_1, \dots, z_k) + 2e_k \mu \varepsilon(t) X_k^{\otimes}, \quad (6)$$

where j - discrete time; z_i ($i=1, 2, \dots$) - arguments of multidimensional z -transformation.

Considering advantages of analog adaptive compensators of nonlinear distortions which allow to suppress nonlinear distortions directly in the radio-receiving devices in real time, but not in the course of further processing [10], it is expedient to pay the main attention to analog adaptive compensators of nonlinear distortions. For discrete adaptive compensators of nonlinear distortions all results can be received similarly [7, 8].

Let's define an error of compensation of the adaptive compensator of nonlinear distortions in the following look

$$V_k(t, f_1, \dots, f_k) \doteq V_k(t) = H_k(t, f_1, \dots, f_k) - W_k(t, f_1, \dots, f_k). \quad (7)$$

Repeating the reasonings similar provided in work [15] and lowering intermediate calculations, it is easy to see that

$$\lim_{t \rightarrow \infty} V_k(t) = 0, \quad \forall k \in [1, \dots, m].$$

In turn it means that

$$\lim_{t \rightarrow \infty} W_k(t, f_1, \dots, f_k) = H_k(f_1, \dots, f_k), \quad \forall k \in [1, \dots, m].$$

So, transfer functions of adaptive filters of adaptive compensators of nonlinear distortions meet in time in nonlinear transfer functions of the radio device. It is possible to show that effective convergence is observed at least until internal noise of the adaptive compensator of nonlinear distortions do not exceed those nonlinear distortions which are compensated in size.

The synthesized adaptive compensators of nonlinear distortions can be used for improvement of qualitative characteristics of a wide class of information systems, in particular - for improvement of spectral characteristics of the radio-transmitting devices, multipliers and synthesizers of frequency, for increase in amplitude characteristics of the radio-receiving devices and repeaters of different function and for optimization of systems of automatic control by criteria of nonlinearity [15]. Besides, developments on the basis of the adaptive compensator of nonlinear distortions of the adaptive measuring installations of essentially new type intended for carrying out direct measurements of nonlinear distortions, and also identification in broad and narrow sense of nonlinear dynamic systems [13, 15] are expedient.

As a result of the carried-out synthesis basic confirmation of an opportunity adaptive the solution of a problem of compensation of distortions in radio devices [6] is received. But, from the practical point of view also assessment of characteristics of accuracy and dynamic characteristics of adaptive compensation of nonlinear distortions which are constructed on the known base [16] of radioelementnitya is important. Therefore for the reasoned answer to a question of real opportunities of the adaptive compensator of nonlinear distortions for expansion of dynamic range of the radio-receiving devices of telecommunication systems, for the purpose of development of an evidence-based technique of design, it is necessary to conduct a research of their qualitative characteristics.

3. Assessment of dynamic characteristics and the accuracy of adaptive compensation of nonlinear distortions taking into account internal noise and not ideality of parameters of their elements

With a research objective of physical capacity of realization and real opportunities of adaptive compensation of nonlinear distortions, and also for development of an evidence-based technique of their design concerning a problem of expansion of linear dynamic range of the radio-receiving devices of telecommunication systems we will carry out the analysis of qualitative characteristics of the adaptive compensator of nonlinear distortions constructed on the basis of the real "rustling" elements with imperfect, generally, parameters.

Dynamic properties of adaptive compensators are, as a rule, characterized by a constant of time of adaptation (reorganization) of adaptive filters τ [16]. According to [6] it is possible to show that usually reorganization happens under the exponential law, and the constant of time of adaptation of the adaptive compensator of nonlinear distortions is defined by the following expression

$$\tau_{ACND} = \frac{k_{\tau_m}}{4\mu P_N}, \quad (8)$$

where P_N – compensation power nonlinear distortion;
 k_{τ_m} – coefficient of proportionality.

Other main characteristic of quality of adaptive compensators is the accuracy of adaptation which is limited to a gradient assessment error ω_1 , and also compensation errors owing to delay of reorganization of adaptive filters ω_2 [9]. For the adaptive compen-

sator of nonlinear distortions the specified mistakes can be defined, respectively, from formulas of a look [7]

$$\omega_1 = k_{\omega_1} \mu P_N, \quad \omega_2 = \frac{1}{\mu} \frac{k_{\omega_2} \sigma_i^2}{4\sigma_{\min}}, \quad (9)$$

where σ_i , σ_{\min} – respectively an average square of an error of nonlinear distortions and the minimum mean square error of adaptation which is implemented in case of optimum creation of adaptive filters; k_{ω_1} , k_{ω_2} – proportionality coefficients.

So, the speed and accuracy of adaptation of the compensator of nonlinear distortions, necessary for a specific objective, can be provided with the corresponding choice of coefficient of transfer μ to a chain of feedback [16]. However, expressions (9) impose contradictory requirements to size μ . Therefore high quality of adaptation (that is the minimum total mistake $\omega_{\Sigma} = \omega_1 + \omega_2 = \min$) can be provided with the choice of optimum value μ_{opt} which is by equating of the right parts of expressions (9) and is defined by a formula

$$\mu_{\text{opt}} = \sqrt{\frac{k_{\omega_2} \sigma_i^2}{4k_{\omega_1} \sigma_{\min} P_N}}. \quad (10)$$

Really achievable an adaptation time constant τ the compensator of nonlinear distortions are, as a rule, ranging from units and tens of nanoseconds to microsec units that it is usually enough for telecommunication systems [16]. Therefore when developing the adaptive compensator of nonlinear distortions the main attention needs to be paid to providing the set requirements to characteristics of accuracy of the adaptive compensator of nonlinear distortions [15].

In the known works devoted to a research of influence of not ideality of elements of adaptive compensators on quality of their work only errors performance of a ratio of mathematical operations [8] were considered generally. It is shown, in particular, that integration errors have significant effect. Rather adaptive compensator of nonlinear distortions the integration error in k-m the channel leads to an error of compensation which is defined by the following formula [8]

$$\lim_{t \rightarrow \infty} W_k(t) = H_k + \Delta H_k, \quad (11)$$

where ΔH_k - the mistake proportional to an integration error.

Thus, requirements to the accuracy of performance of mathematical operations by elements of the adaptive compensator of nonlinear distortions need to be put, proceeding from the most admissible error of compensation of nonlinear distortions for this task in the radio-receiving devices of telecommunication systems.

In the course of the research of efficiency of adaptive compensators influence only external uncorrelated influences of the nonideal optimum adaptive filter (Winer's filter) is considered, as a rule, [13]. However, all real radioelements is "noisy" [1] that causes relevance of the analysis of influence of internal noise of the adaptive compensator of nonlinear distortions on its efficiency [16]. For this purpose we will enter the following designations

$$v_{mche} = \frac{P_{no}}{P_N}, \quad (12)$$

$$v_{he} = \frac{P_{A_0}}{P_N}, \quad (13)$$

where P_N – power, internal noise of the radio device at its exit (on the "main" entrance of the adaptive compensator of nonlinear distortions); P_{A_0} – power of internal noise of actually adaptive

compensator of the nonlinear distortions counted for its entrance (on a basic entrance).

As an indicator of efficiency of the real adaptive compensator of nonlinear distortions which "rustles" we will choose size

$$\Theta \doteq \frac{P_s/P'_N}{P_s/P_N}, \quad (14)$$

where P_s – the power of an alarm component of an output signal of the radio device; P_N, P'_N – the power of nonlinear distortions on the "main" entrance and an exit of the adaptive compensator of nonlinear distortions, is compensated respectively.

As internal noise P_N and P_{A_0} are also not correlated with entrance and output signals of the adaptive compensator of nonlinear distortions, expression for its efficiency coincides with a formula for efficiency of linear adaptive compensators, on condition of influence on their entrances of external uncorrelated signals [1], that is

$$\Theta = \frac{[v_{mche} + 1][v_{he} + 1]}{v_{mche} + v_{mche} v_{he} + v_{he}}. \quad (15)$$

Expression (15) allows to estimate influence of internal noise of the adaptive compensator of nonlinear distortions on its efficiency, it allows to draw an important practical conclusion that internal noise of the adaptive compensator of nonlinear distortions do not lead to decline in quality of functioning of the radio device [17]. When internal noise of the adaptive compensator of nonlinear distortions exceed nonlinear distortions on level, are suppressed, size $\Theta=1$ which is physically equivalent to automatic shutdown of the adaptive compensator of nonlinear distortions and respectively, to the autonomous mode of the radio device.

It should be noted that the accounting of not ideality of parameters of elements of adaptive compensators, generally, is not exhausted by the analysis of influence of errors of performance of functional mathematical operations [18]. The significant effect on qualitative characteristics of adaptive compensators is carried out by inevitable nonlinear properties of real elements. Special value has it for adaptive compensators of nonlinear distortions which are directly intended for suppression of nonlinear distortions in radio devices. Considering insufficient extent of studying of these questions in the known literature, it is necessary to carry out the analysis of influence of nonlinearity of amplitude characteristics of real elements of the adaptive compensator on qualitative characteristics [2]. Let's present output signals of real devices having reduced to k-y of degree, the amplifier of a chain of feedback and remultipliers of adaptive filters in the form of Voltaire's ranks [14]

$$(x_k)^+ = \beta_1 x + \beta_2 x^2 + \dots + \beta_k x^k + \dots, \quad (16)$$

$$(\mu \varepsilon)^+ = \mu_1 \varepsilon + \mu_2 \varepsilon^2 + \dots, \quad (17)$$

$$(Z_k)^+ = a_{10}(x_k)^+ + a_{10}(\mu \varepsilon)^+ + a_{20}[(x_k)^+]^2 + a_{11}(x_k)^+(\mu \varepsilon)^+ + a_{02}[(\mu \varepsilon)^+]^2 + \dots$$

$$(Z_k)^+ = b_{10}\left[\frac{1}{S}(y_1)^+\right] + b_{01}(x_k)^+ + b_{20}\left[\frac{1}{S}(y_1)^+\right]^2 + b_{11}\left[\frac{1}{S}(y_1)^+\right](x_k)^+ + b_{02}[(x_k)^+]^2 + \dots$$

where $(x_k)^+, (\mu \varepsilon)^+, (y_1)^+, (y_2)^+, (Z_k)^+$ – output signals of real devices of construction in k-yu degree, the amplifier of a chain of feedback, the first remultiplier of k-go of the adaptive filter, the second remultiplier of k-go of the adaptive filter (k-go of the adaptive filter) respectively; $\beta_i, \mu_j, a_{ij}, b_{ij}$ – nonlinear transfer functions of the specified elements of the adaptive compensator of nonlinear distortions respectively.

As appears from expression (17), nonlinearity of amplitude characteristics of the amplifier of a chain of feedback lead to restriction of the upper bound of dynamic range with an exit of the adaptive compensator of nonlinear distortions ε_{max} [11]. Admissible level of nonlinear distortions in the amplifier of a chain of feedback can be determined from the set top level of dynamic range with an exit of the adaptive compensator of nonlinear distortions $\varepsilon_{max set}$, for the narrow-band amplifier we have

$$|\mu_3| \leq \frac{1}{|\varepsilon_{max set}|^2} \quad (18)$$

for the broadband amplifier

$$\left. \begin{aligned} |\mu_2| &\leq \frac{1}{k_\mu |\varepsilon_{max set}|} \\ |\mu_3| &\leq \frac{1}{(1-k_\mu) |\varepsilon_{max set}|^2} \end{aligned} \right\}, \quad (19)$$

where k_μ – the coefficient defining a ratio between admissible levels of nonlinear distortions of the second and third orders ($0 \leq k_\mu \leq 1$) also depends on width of bandwidth of the amplifier of a circle of feedback.

Nonlinear characteristics of the device of construction in k-yu lead degree to distortion of an output signal of k-go of the adaptive filter [15]. Follows from a formula (16) that

$$(W_k(t))^+ = W_k(t) + \Delta W_k(t) \cong W_k(t) + \sum_{i=1, i \neq k}^{\infty} [\beta_i W_k(t)], \quad (20)$$

where $[\beta_i W_k(\cdot)]$ – nonlinear transfer function t - ro about makes substantial sense.

It should be noted that the member $\beta_{k+2} W_k(\cdot)$ defines restrictions of dynamic range of the adaptive compensator of nonlinear distortions on its entrance; the component $\beta_j W_k(\cdot)$ causes distortion of an output signal of j-go (neighboring) canal of the adaptive compensator of nonlinear distortions; a component $\beta_n W_k(\cdot)$ leads to distortion of a useful component of an output signal of the radio device, components $\beta_i W_k(\cdot)$ ($i \neq k, k+2, n, j$) increase internal noise of the adaptive compensator of nonlinear distortions [7]. Additional level of noise can be found with the subsequent formula [1, 15]

$$\Delta N_A \cong \left| \sum_{i=1, i \neq k}^m \beta_i W_i(t) X_i \right|, \quad (21)$$

where l - number of the channel of the adaptive compensator of nonlinear distortions; β_i – the nonlinear transfer l-go function of an order of the mechanism of construction in l-m degree of l-go of the channel of the adaptive compensator of nonlinear distortions.

The error which is brought in k-go of the channel of the adaptive compensator of nonlinear distortions at the expense of other its channels, is defined as follows [12]

$$\Delta W'_k(t) \cong \left| \sum_{i=1, i \neq k, n}^m \beta_i W_i(t) \right|.$$

Follows from expression (20) also that the upper bound of its range with an entrance of the adaptive compensator of nonlinear distortions of X_{max} (on nonlinear to distortions of k of an order)

taking into account influence of all its channels depends on size $\Delta W''_k(t)$ which is defined from a ratio of such look

$$\Delta W''_k(t) \cong \left| \sum_{\substack{l=1 \\ l \neq n}}^m \beta_{l,k+2} W_l(t) \right|.$$

From here it is possible to define requirements to nonlinearity $(k+2)$ - go an order of devices of exponentiation [19]

$$\left| \sum_{\substack{l=1 \\ l \neq n}}^m \beta_{l,k+2} \right| \leq \frac{|H_k(t)|^2}{|H_n(t)|} \frac{1}{|X_{\max}|^{|k-n|}}. \quad (22)$$

For assessment of distortion of an alarm component of an output signal of the radio device we will define the relation signal / noise in a basic entrance of the adaptive compensator of nonlinear distortions ρ_{he} so

$$\rho_{he} = \frac{\left| \sum_{\substack{l=1 \\ l \neq n}}^m \beta_{l,n} W_l(t) X_l \right|}{\left| \sum_{\substack{l=1 \\ l \neq n}}^m \beta_{l,n} W_l(t) X_l \right|}, \quad (23)$$

Then the relation signal / noise at the exit is equal [6]

$$\rho_{outp} = \frac{1}{\rho_{he}}. \quad (24)$$

Respectively, distortions of an alarm component of an output signal of the radio device at the exit of the adaptive compensator of nonlinear distortions can be defined as

$$\varepsilon = \frac{\rho_{he}}{\rho_{mche}}, \quad (25)$$

where ρ_{mche} - ρ_{mche} - the relation signal / noise at the exit of the radio device which is determined, in this case, by a formula

$$\rho_{mche} = \frac{|H_n X_n|}{\left| \sum_{\substack{k=1 \\ k \neq n}}^m H_k X_k \right|}. \quad (26)$$

The alarm component in a basic entrance of the adaptive compensator of nonlinear distortions causes also change of a range of nonlinear distortions which are compensated, and [6]

$$\{S_Y\}_{outp} = \{S_Y\}_{mche} \rho_{mche} \rho_{he}, \quad (27)$$

where $\{S_Y\}_{outp}, \{S_Y\}_{mche}$ - a range of nonlinear distortions which are compensated at the exit of the adaptive compensator of nonlinear distortions and at the radio device exit respectively.

Requirements to the level of nonlinear distortions n -go of an order can be defined from the most admissible size ρ_{heA} , as in [6]

$$|\beta_N| \leq \rho_{heA}. \quad (28)$$

It is possible to show that requirements to the level of nonlinear distortions of a remultiplier of adaptive filters are significantly lower than relevant requirements to nonlinearity of amplitude characteristics of devices of exponentiation. Taking into account that devices of exponentiation it is more convenient to realize on the basis of a remultiplier [6, 12], there are all bases in order that requirements to the level of nonlinear distortions of all перемножувачив were identical and conformed to requirements which are imposed to devices of exponentiation.

It should be noted that the results received above can be used not only to adaptive compensation of nonlinear distortions, but also to the analysis of qualitative characteristics of a wide class of the adaptive and self-adjusted systems with the doctrine of internal noise and nonlinear properties of their elements [1].

On put in this dissertation work of tasks we will use results of a research of characteristics of accuracy and dynamic characteristics of real adaptive compensators of nonlinear distortions for development of an evidence-based technique of their design for the purpose of expansion of linear dynamic range of the radio-receiving devices of telecommunication systems.

Let the linear dynamic range of the radio device it is equal

$$D_1 = D_{lent} = 20 \lg \left| \frac{X'_{\max}}{X'_{\min}} \right| \cong D_{outp} = 20 \lg \left| \frac{Y'_{\max}}{Y'_{\min}} \right|, \quad (29)$$

where $|X'_{\min}|, |Y'_{\min}| (|X'_{\max}|, |Y'_{\max}|)$ - the lower (top) bound of dynamic range of the radio device to an entrance and an exit, respectively.

Let's assume that it is necessary to expand the dynamic range of the radio device to size $D > D_1$, where

$$D = D_{ent} = 20 \lg \left| \frac{X_{\max}}{X'_{\min}} \right| \cong D_{outp} = 20 \lg \left| \frac{Y_{\max}}{Y'_{\min}} \right|,$$

$$\left| \frac{X_{\max}}{X'_{\min}} \right| \cong \left| \frac{Y_{\max}}{Y'_{\min}} \right| > 1. \quad (30)$$

It is expedient to begin design of the adaptive compensator of nonlinear distortions with the choice of the adder (the subtraction device) which dynamic range of D_{Σ} has to be not less than D , that is $D_{\Sigma} \geq D$, and

$$\left| \varepsilon_{\Sigma_{\min}} \right| \leq |Y'_{\min}|; \quad \left| \varepsilon_{\Sigma_{\max}} \right| \geq |Y_{\max}|, \quad (31)$$

Where $\left| \varepsilon_{\Sigma_{\min}} \right| (\left| \varepsilon_{\Sigma_{\max}} \right|)$ - the lower (top) bound of range of the adder (the subtraction device).

Let's define requirements to integration accuracy Δ_{int} . As practically and it is expedient to suppress nonlinear distortions of k -go of an order only to within nonlinear distortions of the highest (first of all $(k+2)$) orders, for cascades of the radio-receiving devices of telecommunication systems

$$\Delta_{int1} \leq \Delta H_{3set} \leq |H_{51}|, \quad (32)$$

and for coherent detectors and converters of frequency

$$\Delta_{int2} \leq \Delta H_{31set} \leq |H_{51}|. \quad (33)$$

Let's define requirements to parameters of devices of exponentiation and a remultiplier of the adaptive compensator of nonlinear distortions. Considering single-channel adaptive compensation of nonlinear distortions, from expressions (22) and (28) it is possible to define admissible degree of nonlinearity of a multiplier of in-

tensifying cascades of the radio-receiving devices of telecommunication systems

$$|\beta_l| = |a_{ij}| = |b_{ij}| \leq \left| \frac{H_{31}}{H_{11}} \right|^2 \frac{1}{|X_{\max}|^2}; \quad (34)$$

and also for coherent detectors and converters of frequency

$$|\beta_l| = |a_{ij}| = |b_{ij}| \leq \left| \frac{H_{31}}{H_{11}} \right|^2 \frac{1}{|X_{\max}|^2}; \quad (35)$$

where $l=i+j \neq 2$; $(ij) \neq (11)$; X_{opt} – amplitude of a basic signal (a heterodyne signal).

Requirements to admissible nonlinearity of amplitude characteristics of the amplifier of a circle of feedback can be set from necessary size $|Y_{\max}| \leq |\varepsilon_{\max \text{ set}}| \doteq |\varepsilon_{\Sigma \max}|$ according to formulas (18) and (19). At the same time the coefficient of transfer of the amplifier of a chain of feedback should be found from the accuracy, necessary for this task, and speed of adaptation on formulas (9) and (10) [15]. In some cases optimum value $u_{\text{opt}} \equiv \mu_{\text{opt}}$ lies ranging from 0,1 to 10, and for cascades $\mu_{\text{opt}} \leq 1$, and for final and converting $\mu_{\text{opt}} \geq 1$ cascades [16].

Apparently from a formula (15), internal noise should not a feather-vyshat on level nonlinear distortions are compensated [8]. So, not to impose unreasonably overestimated requirements to fluctuation characteristics of elements of the adaptive compensator of nonlinear distortions, it is necessary to provide performance of the following condition [15]

$$|X'_{\min}| \leq |X'_{\max}|, \quad (36)$$

where $|X'_{\min}|$ – the lower bound of dynamic range of adaptive compensation of nonlinear distortions.

Then D_2 can be necessary the dynamic range of the adaptive compensator of nonlinear distortions is defined from the following ratio [15]

$$D_2 \geq D - D_1. \quad (37)$$

Important practical conclusion that creation of adaptive compensation of nonlinear distortions on problems of expansion of linear dynamic range of the radio-receiving devices of telecommunication systems does not require silent elements with ideal parameters and those which cannot be realized physically is a consequence of it. So, the synthesized adaptive method of compensation of nonlinear distortions physically is implemented on the basis of the known radioelements.

4. Conclusions

Introduction of artificial main and basic entrances to the scheme of nonlinear adaptive compensators allowed to apply the general theory of adaptive systems to their synthesis. Practical use of the adaptive compensators of nonlinear distortions synthesized by such principle according to the developed recommendations, allows to raise significantly indicators of quality of telecommunication systems in actual practice of their application in comparison with known.

Application the offered practical recommendations does not lead to decrease in reliability of telecommunication systems, as in hardware (failure of the adaptive compensator of nonlinear distortions does not involve failure of the radio-receiving devices), and in functional sense (adaptive compensators of nonlinear distortions are automatically disconnected when their application does

not allow to improve the relation signal / noise in the radio-receiving devices).

Additional benefit of the offered adaptive way of expansion of linear dynamic range of the radio-receiving devices is improvement of all-weather capability of telecommunication systems and increase in probability of identification of the radar district maps removed in different conditions without additional perenalash-tuvan. Besides, the flexible stock on a noise stability of telecommunication systems is at the same time provided, allows to consider possible improvements of means of redioelektronny counteraction for the presumable period of operation of an information system.

The adaptive way of expansion of linear dynamic range of the radio-receiving devices is developed allows to add the known technical actions for increase in a noise stability of telecommunication systems, it completely corresponds to the general modern methodology of providing a noise stability of work of an information system.

The synthesized adaptive compensators of nonlinear distortions substantially are free from many shortcomings of the linear determined ways of expansion of dynamic range of the radio-receiving devices, and also have simpler hardware realization. Besides, in the course of design of adaptive compensators of nonlinear distortions it is necessary significantly the smaller volume of aprioristic information on parameters of the radio-receiving devices for calculation of schemes of suppression of nonlinear distortions.

Transfer functions of adaptive filters of adaptive compensators of nonlinear distortions quickly enough meet to nonlinear transfer function of the radio device, and effective convergence is observed in the presence of internal noise to a last resort until they do not exceed the level of nonlinear distortions which are compensated.

Qualitative characteristics of adaptive compensators of nonlinear distortions unambiguously are defined by the level of internal noise and degree of nonideal parameters of real elements of adaptive compensators of nonlinear distortions. As internal noise of adaptive compensators of nonlinear distortions do not lead to additional deterioration of operation of the radio-receiving devices, in comparison with its car-nomnim functioning, extremely achievable dynamic range of adaptive compensators of nonlinear distortions is equal to the sum of dynamic ranges of radio devices and actually adaptive compensator of nonlinear distortions.

The adaptive method of compensation of nonlinear distortions in radio devices which demands considerably the smaller volume of aprioristic information on parameters of radio devices is developed and entered into the theory and practice and in many respects raises indicators of quality of onboard radar-tracking systems.

References

- [1] Michael J. Buckingham (1983), Noise in Electronic Devices and Systems, *Ellis Horwood Ltd, Publisher*, 372.
- [2] Shirman Ya. D. (1981), Theory and technology of processing radar information against interference, *Radio and communication*, 248.
- [3] Polyak B. T. (1980) Robust Adaptation Algorithms, *Automation and Remote Control*, No.10, 91-97.
- [4] Shefer O. V. (2017), The increase of radio technical noise immunity systems by adaptive premaligant and inversive correlation approach to the detection of the beneficial signal, *Scientific Notes UNDIZ*, No. 1(45), 82-88.
- [5] Gutkin L. S. (1986), Designing radio systems and radio devices, *Radio and communication*, 288.
- [6] Shirman Ya. D. (1998), Radio-electronic systems: the basics of construction and theory, *ZAO Makvis*, 828.
- [7] Chernyshov, V.P. (1989), Propagation of radio waves and anti-feeder devices, *Radio and communications*, 240.
- [8] Korn G. (1984), Handbook of Mathematics for Scientists and Engineers Science, 831.
- [9] Tikhonov V. I. (2015), Statistical analysis and synthesis of radio engineering devices and systems, *Hotline-Telecom*, 608.

- [10] Pogorelov A. I. (1988), Analysis of systems for processing complex space-time signals, *Signal processing in radio engineering systems, KhAI*, 164-173.
- [11] Shefer O. (2014), Algorithm of identification of nonlinear technical systems according to measured data, *Control, Navigation and Communication Systems*, No. 3 (31), 91-95.
- [12] Mazora, Yu. L. (1999), Radiotekhnika: Encyclopedic Primary School; Primary School, *Higher School*, 838.
- [13] Shakhtarin B. I. (2008), Wiener and Kalman Filters, *Helios ARV*, 304.
- [14] Maas, Stephen A. (2003), Nonlinear microwave and RF circuits, *2nd ed. Boston; London: Artech House*, 582.
- [15] Kim D. P. (2004), Theory of automatic control Multidimensional, nonlinear, optimal systems, *FIZMATLIT*, 464.
- [16] Chernega VS (1990), Calculation and design of technical means of exchange and transfer of information, *Higher School*, 224.
- [17] Kazarinov Yu. M. (1990), Radio engineering systems, *Higher School*, 496.
- [18] Landau M. Application of the Volterra Series to the Analysis and Design of an Angle Track Loop, *IEEE Trans*, 1972, V. AES-8, No 3, 306-318.
- [19] Polyak B. P. (1980), Robust Adaptation Algorithms, *Automation and Remote Control*, No.10, 91-97.
- [20] Cherniha, R., & Serov, M. (2006). Symmetries, ansätze and exact solutions of nonlinear second-order evolution equations with convection terms, II. *European Journal of Applied Mathematics*, 17(5), 597-605. <https://doi.org/10.1017/S0956792506006681>
- [21] Popova, A. V., Kremenetsky, V. G., Solov'ev, V. V., Chernenko, L. A., Kremenetskaya, O. V., Fofanov, A. D., & Kuznetsov, S. A. (2010). Standard rate constants of charge transfer for nb(V)/Nb(IV) redox couple in chloride-fluoride melts: Experimental and calculation methods. *Russian Journal of Electrochemistry*, 46(6), 671-679. <https://doi.org/10.1134/S1023193510060121>