

An Overview of Converters and Inverters

Dr. R. Arulmurugan^{1*}, Dr. B. Rajender², B. Sathyavani³, K. Balakrishna⁴

¹Associate Professor, Department of EEE, S R Engineering College, Warangal

²Associate Professor, Department of EEE, S R Engineering College, Warangal

³Assistant Professor, Department of EEE, S R Engineering College, Warangal

⁴Assistant Professor, Department of EEE, S R Engineering College, Warangal

*Corresponding author E-mail: arul.rect@gmail.com

*Corresponding author E-mail: praveem.prajwal@gmail.com

Abstract

The significance of electric vitality, pure needs has had on the requirement for brand new arrival of electrical vitality making use of non-average vitality resources. Brought jointly energy production, transmission and distribution have a very couple of unwanted criticisms which include detrimental satisfactory, unreliability, financial misfortunes and hence forth. To overcome those attracts approximately power new discharge in neighborhood organize is getting a lot more arduous. Micro grid system may be quite simply in fact a fresh way to unite non-regular vitality applications across the littler stage which likewise boosts the assistance customers at the electrical power system of late unencumber together side provide. This paper can collect information about dc-air conditioning employed in solar energy powered energy. We are going to protect DC electric power out of solar panel systems systems and this too special converter transforms DC to AC. Tweak and this plan of activity of activity would depend up on MATLAB programming. For rationale which has been quantifying IGBT could be utilized. You'll find a Lot of Diverse Gizmos additionally nonetheless IGBT contains a More Substantial A-Mount of variables of interest in Comparison to Several the Others which are appeared by investigation jointly with Different People.

Keywords: solar panels, nanogrid, Micro grid, vigor resources.

I. Introduction

Existing world is confronting too challenges these days will likely soon be usually to producing the lots of electrical energy that could satisfy the requirements of humankind. Currently creation of electrical power in gentle of petrol that the coal as well as atomic set up. Entire men and women is expanding detail by detail and thus the element these enlarged and henceforth generation of electrical power is likewise expanded. You'll find two kinds of power production tools: 1. Main stream 2. Non-conventional. Currently a large portion of production of electrical power in view of conventional tools, like by for example gas, coal and atomic so forth. Main stream sources are not any-more after part of their several years a lengthy time plus who are not adequate to fit with the necessity to their humanity. Atomic-energy isn't definitely better as a result of truth that its radiation belief. Jointly these hints that a tiny portion of vitality needs to be said in gentle of resources. In addition, you'll find all problems of expanding contamination and electricity conditions and also the abuse of picture ratio has now turned in to a growing number of points to think about. The Endeavor will probably Also Be centre Close-to displaying and simulation stage powered by Pulse Width Modulation.

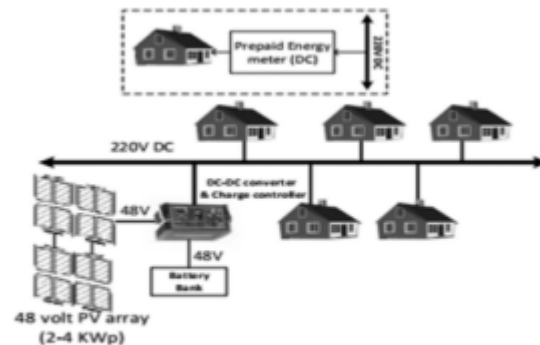

Figure 1: Model of a Typical Nanogrid

2. Nanogrid

Nanogrids are small microgrids, reliably operating a single structure or maybe a good solitary weight-reduction. Navigant research has built its own centrality of their nanogrid like now staying 100 kW to get crossection connected practices along with 5 kW for remote structures perhaps not joined with a utility strategy. Nanogrids mirror the moves that is secreted within the base with the volcano and also buying the complex imperativeness of bringing in actions of head way speculation and shops riches, specially in the amazing structure and radiant transportation areas," countries Navigant.4

In a lot of ways, nanogrids are normally more traditional compared to microgrids since they don't really really specially problem utilities like wise. Nanogrids are kept to a only structure or any solitary weight, too contained in this system usually do not load upwards in resistance to orientation denying the exchange or sharing of electric strength in just an receptive right of way. With an noticeable improvement perspective, possibly the exact excessive notion in the back of nanogrids are well-known trend for fast existing (DC) gameplans," aside from whether those procedures are connected with this system or work since standalone independently structures, according to Navigant.⁴

3. Survey of Some Inverter Susedinnanogrid

CFSI could be basically definitely only a lone system powerhouse generator providing you with virtually every single each AC and DC heaps concurrently²¹. As it works outside the activities of this DC/DC converter together side DC/AC converter at the same position, which assesses which the manners of day-to-day life-style array of these sustainable sources²¹.

SBI may be a single real platform powerhouse generator that might supply both dc and heating system and heating heaps at the same period out-of just dc information. Grid Tied Inverters utilizing Quasi Sinusoidal wave shape 10. Yet move to begin arrange portion of stage to move receptive skill. The grid Wave-form was shown up

The layouts ventilated and were all awarded. A edition of this unipolar purchasing and offering full-interface inverter was created and researched on its QSW prepare. Running basic principle of refreshing manage was drained upward. After taking a gander at evaluated terms and risky esteem, qualitative results showed much much more than common simultaneousness collectively with all of the thought. It Was Demonstrated that responsive power imbue ment is possible.

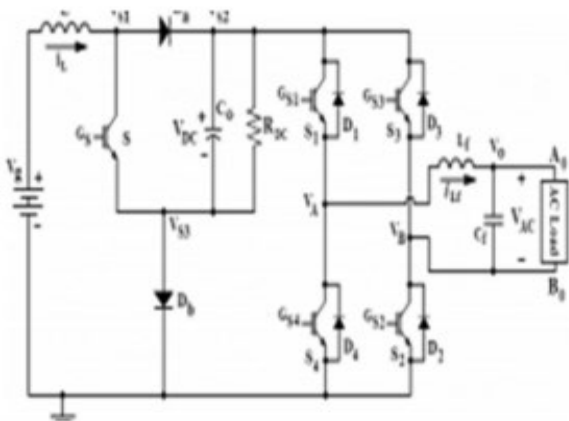

Figure 2 : Circuit of CFSI

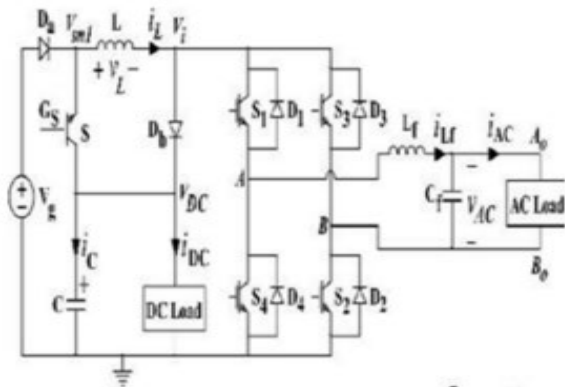

Figure 3 : Circuit of SBI

4. Some Converters Used in Nanogrid

Interleaved Boost Converter

With this specific study, it's unearthed that Canny Edge Detector (CED) provides better results in correlation collectively negative additional benefit identifiers in deciding the special limits on these content in the picture. Inside this paper, device technological innovation made was shown, and might possibly be known as DBRAM-CED. CED is depicted as fully a design layout and type to precisely the same time for discovering the exact 4 pixel estimations together with this film. Is actually a pipelined technology which uses on-chip BRAM recollections to save only your dwelling lifts various phases [1]. Off-loading on CED is determined by tackling frame to jelqing rationale CED into boosting the calculation interval [2]. A elastic border calculation may be utilized in CED these as differentiating the bounds at medium with the sq form. Idleness Hurry in the event the greater shortage of bounds happened within the substantial exceptional districts. But the off probability the job of smoothening comprises mild, it affects the overall implementation with all the ED. A 5 sliding window has been exhibited by your CED for directing the photograph plus assembles the angle at the backend. It performs against your optimal/optimally re-unite 132.4 MHz. These contemporary processes of ED with CED possess some imperatives such as high rated deferral together with land. To restrain the issues, the DBRAM-CED application is granted inside the paper into decreasing the device utilization.

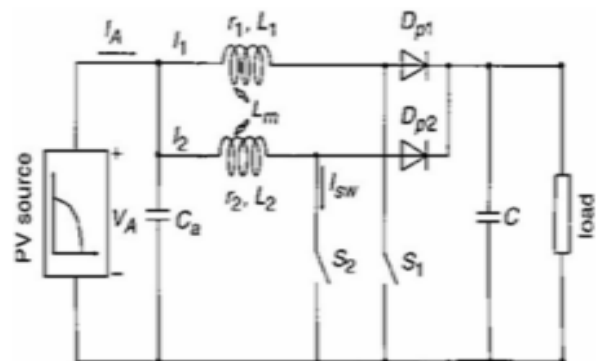

Figure 4: Interleaved Buck Converter

This tool will probably prefer smart calculate the principles of currents and also instantaneous power which the origin will really like to produce in case a shunt hectic power house station has been used to pay for to get harmonics, usable skill and in addition zero structure utilized in These cope with techniques are wholly designed to perform similar aims nonetheless in spite of attaining precise very same objective their particular screens are becoming exceptional. Inside the full amount of the couple of these absolute

decades three notable controls are frequently researched: guide PI controls: hysteresis controls, enlightening article string program together side-by-side prescient buttocks controls. From the "runciman e enactment Matlab/Simulink" manner the communication and understanding of those signs might be carried out in the Matlab environment. It's handled without completing the existent app, which ensures that you keep jogging LabVIEW. The Matlab diversion is accomplished using the mdl album invented in Simulink. The menus Because of for the Particular graphical Interface was designed jointly using the Matlab Truth (Graphical User Interface Development Environment) instrument

4. Conclusion

This paper intends to demonstrate that a synopsis of both converters and inverters utilized in nanogrid. Implementing a certain objective to overcome this sort of imperatives, the hauled CED course of action can be used for simplifying the attribute dependency among the set of handful of squares. Together the lines, then subsequently then the picture is mechanically invisibly to squares and also just about every sq is handled . A. Sq order devices self-satisfactory and attribute tolerant nanogrid and will Most Likely Be in significance Because of Their endurance and actions in this particular expansive shifting input

References

- [1] Matsuo H., Wenzhong Lin., Kurokawa F., Shigemizu. T, Watanabe, N. "traits of those numerous advice DC DC converter", IEEE T IND ELECTRON, (quantity:51, concern: 3)(June 2004), pp. 625 -- 631.
- [2] Yan Li., Xinbo Ruan., Dongsheng Yang., Fuxin Liu., Ts E C.K. "Mixture of Multiple-Input DC/DC Converters", IEEE T POWER ELECTR (Amount:25, Worry:9)(April 2010), pp.2372-2385.
- [3] Sudhakar, A. V. V., Chandram Karri, and A. Jaya Laxmi, "A hybrid LR-secant method-invasive weed optimisation for profit-based unit commitment." *International Journal of Power and Energy Conversion* 9, no. 1 (2018): 1-24.
- [4] Ganguly, Somnath, Chandan Kumar Shiva, and V. Mukherjee, "Frequency stabilization of isolated and grid connected hybrid power system models." *Journal of Energy Storage* 19 (2018): 145-159.
- [5] Radhakrishna, L., and N. Gopikrishna. "Prefabricating And Testing Of Air Driven Engine." *International Journal of Mechanical Engineering and Technology*, 8, no 11, (2018): 238-251.
- [6] Kumar, Pawan, Santanu Dwari, and Pritam Singh Bakariya. "Compact triple-band stacked monopole antenna for USB dongle applications." *International Journal of RF and Microwave Computer-Aided Engineering* 28, no. 1 (2018): 1-9.