

# Smart Educational System: Web-based Low-Cost Remote Laboratory for Electronic Practical Work

A.Abouhilal<sup>1\*</sup>, A.Moulay taj<sup>1</sup>, N.Taifi<sup>1</sup>, A.Malaoui<sup>1</sup>

<sup>1</sup> Research Team in Electronics, Instrumentation and Measurements,  
Polydisciplinary Faculty, Sultan Moulay Slimane University, Beni Mellal, Morocco

\*Corresponding author E-mail: [a.abouhilal@usms.ma](mailto:a.abouhilal@usms.ma)

## Abstract

The implementation of smart technologies is an important part of scientific research especially in the areas of new information and communication technologies, the Internet of Things, wireless sensor network. Among other things, smart educational systems have been a success through videoconferences, classroom response systems and remote labs. Scientific research on remote laboratories has undergone remarkable development in recent years. The remote practical work often uses very expensive proprietary instruments and software. The purpose of this paper is to present a low-cost architecture based on the co-operation of two embedded systems, Raspberry and Arduino. The student accesses the practical work via a web page developed with HTML / Javascript provided by a NodeJs server hosted in the Raspberry. A software oscilloscope has been developed with Processing integrable in the web page to visualise the measured signals from the practical work board.

**Keywords:** Smart System; Remote lab; Raspberry; Software oscilloscope; Practical work; Electronic Experiment; Smart cities.

## 1. Introduction

The evolution of smart cities has made great progress over the last decade through several research projects in the following areas: Internet of Things (IOT), Wireless Sensor Network (WSN), Cloud Services (CS), Smart Grid (SG), Intelligent Transport System (ITS), etc. The use of IOT in classrooms includes remote access control, air conditioning, automatic identification of the presence of students, etc. Practical teaching plays a very important role in the learning process of the student. Practical work is a key pillar for designing practical skills and deepening the theoretical knowledge of lectures [1, 2]. The traditional method of teaching practical work (PW) requires the presence of a teacher, a physical material that is heavy and expensive, a laboratory preparer, and the existence of the student in a classroom and this in a limited opening time slot [3, 4]. Indeed this combination becomes difficult to achieve because of the huge number of students enrolled and sometimes the lack of teachers, premises or equipment. To answer this problem, several researchers have benefited from the development of new information and communication technologies, especially the Internet [5-7]. They have developed solutions aimed at minimising the cost of carrying out these labs and optimising human and logistical resources, while keeping the aims and pedagogical approaches of practical work. There are several solutions in the literature that benefit from the digital domain: Virtual labs, where access is remote, but PW resources are virtual. In this case, the design of the PW is based on a mathematical model. The student performs the manipulation with an interface accessible online through the Internet. The advantage of this method is that many students can handle the same virtual system at the same time [8]. Remote Labs, Access is remote to resources that are actually installed in a physical lab. This access

is available via the Internet or the student interacts with the hardware with an interface [9, 10].

This last approach is very promising as it provides many advantages to know [1]: Accessibility for people with disabilities who need an unavoidable effort to move to the institution; Availability at any time and from any place in the world; Observability from where the manipulation can be followed by several people and even be recorded; Safety in such a way the material and the manipulator have no risk during a PW.

Several remote laboratories have been designed and developed in recent years: WebLab Deusto: developed by the University of Deusto in Spain. It provides a tool to develop other remote labs. In addition, it links practical work shared between several institutions [11]. Labshare: a network of remote laboratories shared between universities. The University of Technology Sydney develops it [12]. ILab: developed by MIT in collaboration with Microsoft research in the USA. The MIT iLab project has developed a distributed services infrastructure with a software toolkit to support the wide use of remote labs [13]. EOLES: a project funded by the European Union. It is hosted in the University of Limoges and shared with European and other universities of North Africa [14]. This project is based on the use of a low-cost architecture of remote laboratories. It is developed with the pduino card which runs under linux. The server side part is designed with NodeJs and the client side part is programmed with HTML5 and Javascript. For the instruments, Malaoui et al [15], presented the oscilloscopes and low-frequency generators used, which have network access via RJ45 whose interface is accessible via the web. From the point of view of the feasibility of implementing these solutions for institutions that have a limited budget in order to invest for very expensive payment solutions, whether it is at the hardware level (commercial electronic cards, digital oscilloscopes, generators of low frequencies ..) or at the software level (LABVIEW, MATLAB, ...)[16].

Our approach is to develop a lightweight, feasible, easy-to-duplicate and low-cost remote lab architecture based on embedded systems and open-source software.

This paper presents a remote PW in electronics, using a client / server architecture based on embedded systems, Arduino and Raspberry, the NodeJS technology, and software digital oscilloscope.

## 2. Related Work

In general, several works have presented the contributions and approaches of practical teaching as follows: Dormido et al. [17] has precisely defined virtual laboratories remotely, so he has presented his advantages, his drawbacks and his fallout on the practical teaching of control engineering. Gustavsson et al. [18] has justified the importance of remote practical experiences in front of virtual ones that are based on predefined models, which does not allow the student to confront changes in the physical world. Other researchers discussed the approaches to creation, management and sharing of remote laboratories: Garçia Zubia et al. [19] introduces client-side and server-side technologies to develop RL. He analyzed bandwidth, browsers, security, etc. three technologies are compared (python, java, .Net). Gomes et al. [5] summarized the available development technologies, so he presented several examples of RL for teaching industrial electronics. A client / server architecture was proposed by Ferrero et al. [20], it is based on a framework, with java client side and LabVIEW server side, using HTTP, TCP / IP and FTP as communication protocols. Ertugrul et al. [21] describes the importance of RLs with LabVIEW and gave examples of several applications in the areas of electronics, electrical engineering, instrumentation, and so on. In the field of control engineering, Sanchez et al. [22], describes a RL for controller an inverted pendulum using java. Casini et al [23] describes a RL with MATLAB / Simulink to choose the law of control; moreover it makes it possible to change the parameters of control in real time and at a distance. In chemistry, Koretsky et al. [24] presents a VL for chemical vapour deposition process. From where Shin describes a VL based on C++, Java and Visual Basic technologies. In electrical genius, Ferrero et al. [25] presents this time a RL based on java for electrical measurements, and in Ko et al. [26]

instrumentation describes an oscilloscope intended for RL, it uses real video captures of the oscilloscope and LabVIEW to control the local instruments. Malaoui et al. [15] gives a new strategy for implementation and validation of RL in the field of power electronics.

## 3. Materials and Methods

### 3.1. Description of the remote lab

The general architecture is based on the Raspberry card as much as a web server. It is connected to the Internet via Wifi. In addition, it is connected to the Arduino USB COM port, to ensure cooperation in the processing of data generated figure 1. For the generation of signals and the measurement of voltage are done with Arduino. The user can change the frequencies generated with the PWM thanks to a web interface. The analog-to-digital converter (ADC) measures the voltages coming from the PW board, and then the data is sent via the USB port to the Raspberry for display in the oscilloscope. The core of our proposition a Raspberry Pi Which it is used to control the PW card with the digital ports. Thanks to these different connection methods RJ45, Wifi and Bluetooth, it plays the role of a low-cost server that provides a web page programmed with sockets technology NodeJs. Moreover, we install an Arduino Uno that's plays two essential role, acquiring data via its ADC and processing this data to send them to the oscilloscope software. Relay plays the role of a switch-matrix that connects the three parts of this architecture the Raspberry, Arduino and PW card.

The practical work module is designed to provide the student with several possibilities of combinations. The present example is a PW of charge/discharging of a capacitor. Figure 2 shows the different combinations of R and C.

In the other hand, the software part of our architecture consists of two parts: client / server communication and software oscilloscope. Were, the client part has been created with HTML and JavaScript to facilitate the access to the users by any navigator also so that the solution is light for connections of low bandwidth. The server-side language is NodeJs. This technology ensures the asynchronous aspect when handling in real time.

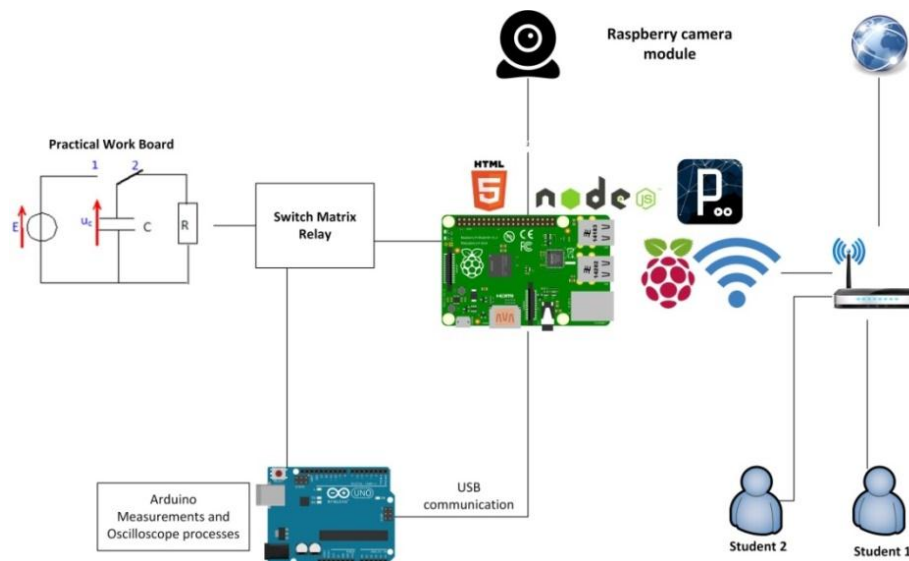

Fig. 1: General architecture

Instead of using a very expensive physical oscilloscope, we have developed an open-source oscilloscope developed with Java-processing and which provides several advantages (visualization of four signals at a time, modification of the frequency of the signal generated by Arduino, etc) figure 3. Part of the application is hosted in the Raspberry to view the signals and another part is

developed with Arduino that allows the acquisition, processing and sending of data to the Raspberry via the COM port.

Figure 2 shows the electronic diagram of our practical work. The relays are represented by switches (SW) which are controlled by the Raspberry via the outputs from I/O1 to I/O6, where the first 3 relays control 3 capacitors and the other 3 relays control the 3

resistors. This combination allows the student to test 9 combinations of R and C. SW7 allows to visualise the signal generated by PWM of the Arduino and SW8 gives us the signal of the capacitor charge/discharge.

### 4. Results and discussion

#### 4.1. Technical result

First the student places himself in front of a web interface via the local IP address 172.16.153.162:5000. This page consists of three essential parts:

- An interactive diagram allows the student to change the status of the switches to control the relays and the PW board. The relays control the possible combinations of R and C and also the oscilloscope channels.
- A dynamic oscilloscope that makes it easier for the student to visualise the charge/discharge phenomena of a capacitor.
- The webcam which gives the possibility to follow in real time what is happening on the PW board.

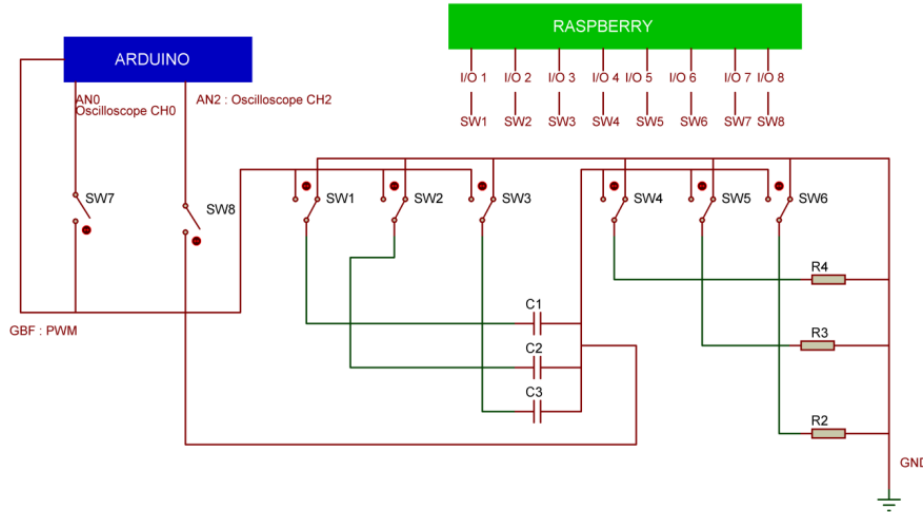

Fig. 2: Web practical work connections

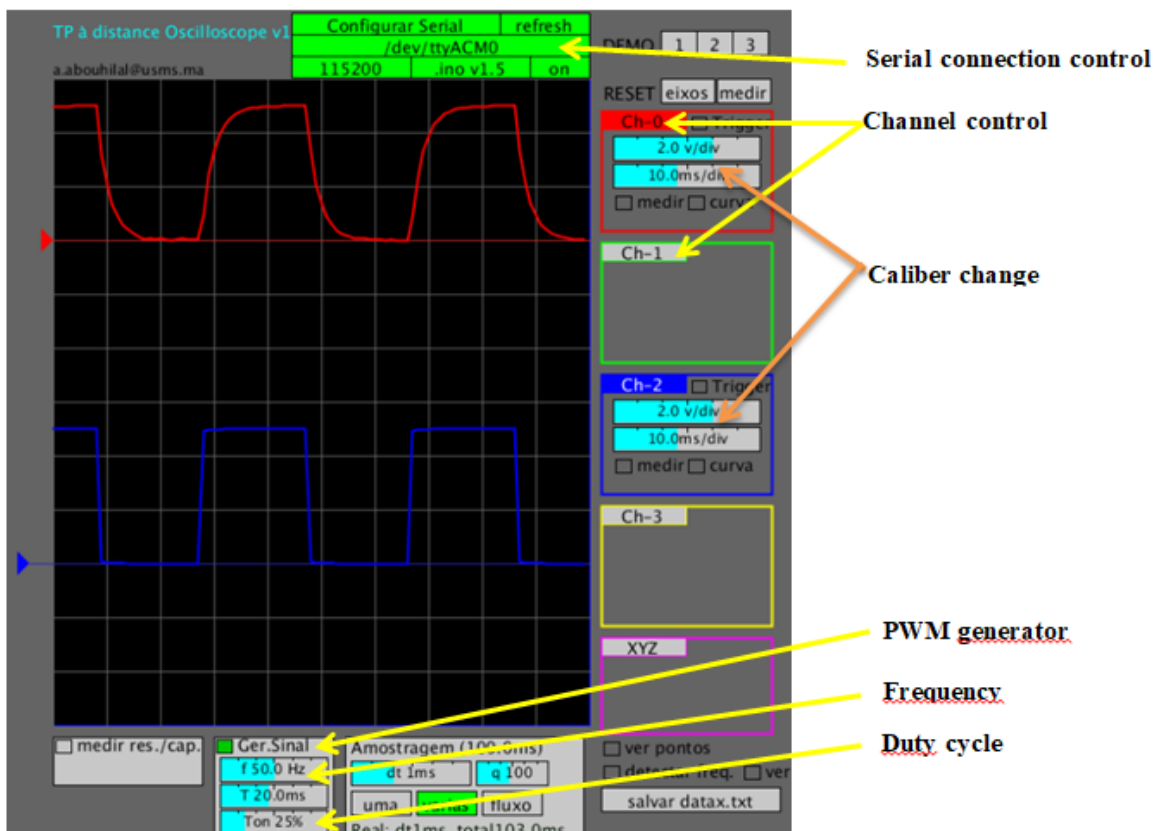

Fig. 3: Developed software oscilloscope-GBF

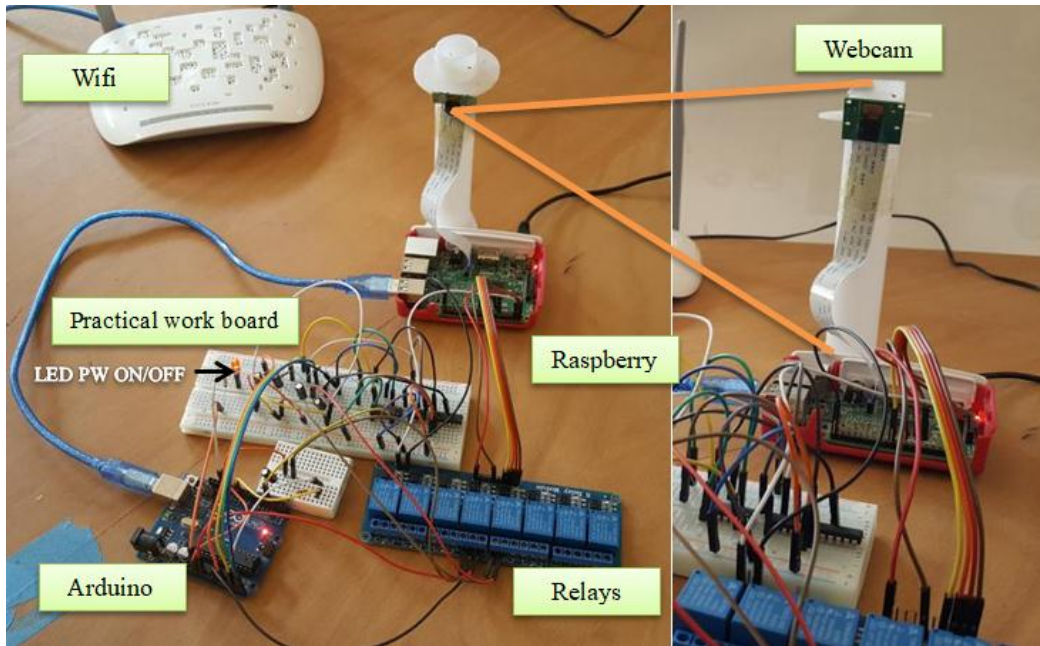

Fig. 4: Realized hardware manipulation

4.2. Methodology

A sample of 20 students in electronic tested the proposed prototype. They were divided in two groups; the first one handles the manipulation locally, where the second use the remote PW. At the end of each of the manipulations, the students were invited to fill a questionnaire of 4 questions, see table 1. The questions to both groups are presented in Table 1. A K factor is calculated using both equations (1) and (2), where S is the average of the student responses for each question and K is the percentage of S by the number of choices in each question. in our case N = 10

represents the number of students in each group and M = 4 is the number of answers for each question [26].

$$S = \frac{1}{N} \times \sum_j R_j \tag{1}$$

$$K = \frac{S}{M} \times 100 \tag{2}$$

Table 1: Evaluation questionnaire

Factor	Questions	Response degree	Hands-on PW %	Remote PW %
Q1	Was the oscilloscope easy to understand and use?	4 - Yes, totally 3 - Yes, partially 2 - Not so much 1 - Not at al	80	80
Q2	Does the PW reinforce your theoretical concepts?	4 - Very clear 3 - Quite clear 2 - Not very clear 1 - Not clear at all	75	72.5
Q3	Was the time enough to handle the PW?	4 - Yes, totally 3 - Yes, partially 2 - Not so much 1 - Not at al	82.5	95
Q4	Were you able to understand how to manipulate the PW without the presence of the teacher?	4 - Yes, totally 3 - Yes, partially 2 - Not so much 1 - Not at al	85	82.5

4.3. Discussion

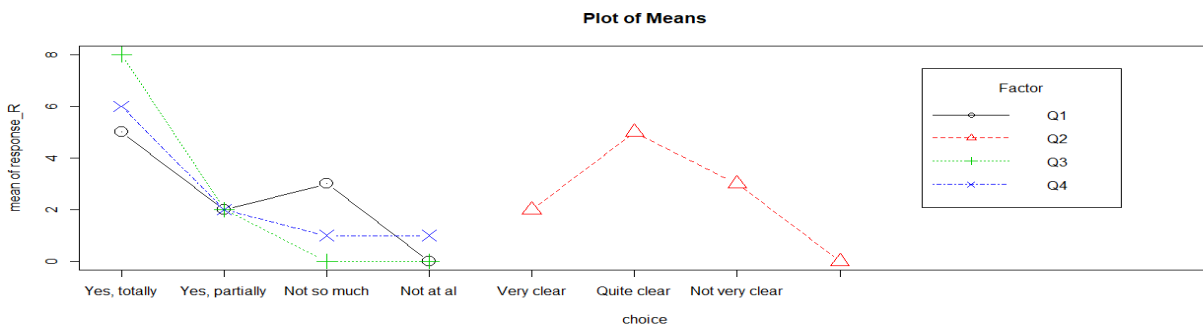

Fig. 5 : Means of the responses in remote practical



Fig. 6 : Means of the response in hands-on practical word

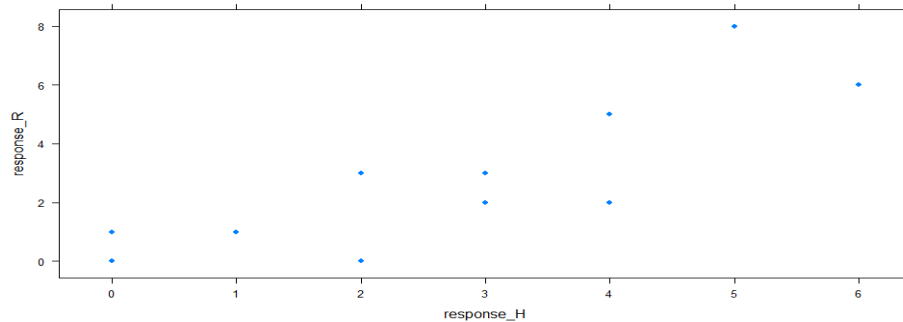

Fig. 7 : The correlation between the answers in remote experience and hands-on one

The analysis of the responses in Table 1 shows several important points. According to figure 5, several students chose the answer "Yes partially" for the remote laboratory, which shows a major satisfaction. Comparing the results with those in Figure 6, we find a great similarity, and this is proven in Figure 7, which presents the correlation between the variables of the students' responses for the remote labs with the classic labs. According to figure 7, one notes that the correlation is almost linear with a coefficient  $R = 0.851102$  that is a positive number close to one, which allowed us to estimate other answers via the following equation:

$$\text{Response}_R = 0.67744 \times \text{Response}_H + 0.8140 \quad (3)$$

We have developed a system of remote laboratories for practical work in electronics as shown in figure 4. Preliminary tests present the experimental results discussed above.

On the architecture level, it is modular as each part of the system can be independently developed and improved, which allows using this system for other practical work easily by changing the PW board and web schema. Moreover, in terms of cost, our developed system is cheaper than those using measuring instruments and low-frequency generators. We replaced these with an embedded system controlled by a web page. Indeed, the cost of our system is around 80 euros. The developed oscilloscope/GBF provides several advantages, it is accessible via the web and plays two essential roles, the visualization of the signals by 4 channels and it generates them by PWM. The student can change the frequency, duty cycle. This software oscilloscope facilitates the duplication of prototypes of practical work without misguided cost or development time. But this oscilloscope has some disadvantages and limitations because its performance (maximum frequency, max. voltage, number of channels, conversion time, processing speed, etc.) depends directly on the on-board system used.

At the level of the embedded system, cooperation between Arduino and Raspberry makes it possible to lighten the operations executed by the server in such a way, the latter takes care of web communications, control of digital outputs and serial communication via USB, where the Arduino takes care of the conversion of analog signals and they process them to provide the

final result to the server. The client/server communication is ensured thanks to the NodeJs socket. A delay was noticed between the web click and activation on relays with an average of 0.85 s, including 0.3 s between the web page and the server. One of the concerns being improved is the real-time synchronization of the webcam, which has a delay of 1.5 s due to the use of the transfer of a set of images captured via sockets.

## 5. Conclusion

This paper has a light architecture, breakable and easy to duplicate, manipulations controlled remotely. This proposal has several advantages: Lightweight, usable for low bandwidth connections, thanks to the developed technologies used. Modular, each module can be developed individually, which allows to develop other PW and to improve each module independently. Low-cost, thanks to embedded systems and open-source technologies, the cost of development and encouraging for institutions that do not have a large budget to mount practical work. The contribution of this paper is the integration of a software oscilloscope accessible via a web page. This will optimize the use of very expensive instruments for measuring, viewing and signal generation.

## References

- [1] R. Heradio, L. De La Torre, D. Galan, F. J. Cabrerizo, E. Herrera-Viedma, and S. Dormido, "Virtual and remote labs in education: A bibliometric analysis," *Comput. Educ.*, vol. 98, pp. 14–38, 2016.
- [2] R. Heradio, L. de la Torre, and S. Dormido, "Virtual and remote labs in control education: A survey," *Annu. Rev. Control*, vol. 42, pp. 1–10, 2016.
- [3] J. R. Brinson, "Learning outcome achievement in non-traditional (virtual and remote) versus traditional (hands-on) laboratories: A review of the empirical research," *Comput. Educ.*, vol. 87, pp. 218–237, 2015.
- [4] A. Malaoui, "Low cost pedagogic device for Practical Works using embedded system," in *2015 IEEE/ACS 12th International Conference of Computer Systems and Applications (AICCSA)*, 2015, pp. 1–8.
- [5] L. Gomes and S. Bogosyan, "Current Trends in Remote

- Laboratories,” *Ind. Electron. IEEE Trans.*, vol. 56, no. 12, pp. 4744–4756, 2009.
- [6] V. M. Cvjetkovic and M. Matijevic, “Overview of architectures with Arduino boards as building blocks for data acquisition and control systems,” *Int. J. Online Eng.*, vol. 12, no. 7, pp. 10–17, 2016.
  - [7] A. Abouhilal, A. M. Taj, R. Irkettou, M. Mejdal, and A. Malaoui, “Development and Testing of a Remote Laboratory for Practical Work Based on Embedded Electronics,” *J. Fundam. Appl. Sci.*, vol. 10, no. 4S, pp. 487–490, 2018.
  - [8] B. Balamuralithara and P. C. Woods, “Virtual laboratories in engineering education: the simulation lab and remote lab,” *Comput. Appl. Eng. Educ.*, vol. 17, no. 1, pp. 108–118, 2009.
  - [9] G. Tabunshchik, D. Van Merode, P. Arras, and K. Henke, “Remote experiments for reliability studies of embedded systems,” *Proc. 2016 13th Int. Conf. Remote Eng. Virtual Instrumentation, REV 2016*, no. February, pp. 74–77, 2016.
  - [10] A. Abouhilal, M. Mejdal, and A. Malaoui, “Design and Development of Practical Works for Remote Laboratories,” in *International Arab Conference on Information Technologies*, 2016.
  - [11] J. Garcia-Zubia, I. Angulo, L. Rodriguez-Gil, P. Orduna, and O. Dziabenko, “Boole-WebLab-Deusto: Integration of a remote lab in a tool for digital circuits design,” in *2013 IEEE Frontiers in Education Conference (FIE)*, 2013, pp. 848–854.
  - [12] M. Tawfik *et al.*, “Shareable educational architectures for remote laboratories,” *Proc. - 2012 Technol. Appl. to Electron. Teaching, TAAE 2012*, pp. 122–127, 2012.
  - [13] S. Colbran and M. Schulz, “An update to the software architecture of the iLab Service Broker,” *Proc. 2015 12th Int. Conf. Remote Eng. Virtual Instrumentation, REV 2015*, no. February, pp. 90–93, 2015.
  - [14] A. Malaoui, M. Kherallah, L. Ghomri, G. Andrieu, T. Fredon, and D. Barataud, “New strategy for remote practical works in power electronics for embedded systems: Application in EOLES European project,” in *The Third International Afro-European Conference for Industrial Advancement, Advances in Intelligent Systems and Computing*, 2018, vol. 565, pp. 149–158.
  - [15] A. Malaoui *et al.*, “Implementation and validation of a new strategy of online practical works of power electronics for embedded systems,” *Int. J. Online Eng.*, vol. 13, no. 4, pp. 29–44, 2017.
  - [16] M. Abdulwahed and Z. K. Nagy, “Developing the TriLab, a triple access mode (hands-on, virtual, remote) laboratory, of a process control rig using LabVIEW and Joomla,” *Comput. Appl. Eng. Educ.*, vol. 21, no. 4, pp. 614–626, 2013.
  - [17] S. D. Bencomo, “Control learning: Present and future,” *Annu. Rev. Control*, vol. 28, no. 1, pp. 115–136, 2004.
  - [18] I. Gustavsson *et al.*, “On Objectives of Instructional Laboratories, Individual Assessment, and Use of Collaborative Remote Laboratories,” *IEEE Trans. Learn. Technol.*, vol. 2, no. 4, pp. 263–274, Oct. 2009.
  - [19] J. Garcia-Zubia, P. Orduna, D. Lopez-de-Ipina, and G. R. Alves, “Addressing Software Impact in the Design of Remote Laboratories,” *IEEE Trans. Ind. Electron.*, vol. 56, no. 12, pp. 4757–4767, 2009.
  - [20] A. Ferrero and V. Piuri, “A simulation tool for virtual laboratory experiments in a WWW environment,” *IEEE Trans. Instrum. Meas.*, vol. 48, no. 3, pp. 741–746, 1999.
  - [21] N. Ertugrul, “Towards Virtual Laboratories: A Survey of LabVIEW-based Teaching/ Learning Tools and Future Trends,” *Int. J. Eng. Educ.*, vol. 16, no. 3, pp. 171–180, 2000.
  - [22] J. Sanchez, F. Morilla, S. Dormido, J. Aranda, and P. Ruiperez, “Virtual and remote control labs using Java: a qualitative approach,” *IEEE Control Syst.*, vol. 22, no. 2, pp. 8–20, 2002.
  - [23] M. Casini, D. Prattichizzo, and A. Vicino, “The automatic control telelab: a user-friendly interface for distance learning,” *IEEE Trans. Educ.*, vol. 46, no. 2, pp. 252–257, 2003.
  - [24] M. D. Koretsky, D. Amatore, C. Barnes, and S. Kimura, “Enhancement of Student Learning in Experimental Design Using a Virtual Laboratory,” *IEEE Trans. Educ.*, vol. 51, no. 1, pp. 76–85, 2008.
  - [25] A. Ferrero, S. Salicone, C. Bonora, and M. Parmigiani, “ReMLab: a Java-based remote, didactic measurement laboratory,” *IEEE Trans. Instrum. Meas.*, vol. 52, no. 3, pp. 710–715, 2003.
  - [26] C. C. Ko *et al.*, “A large-scale Web-based virtual oscilloscope laboratory experiment,” *Eng. Sci. Educ. J.*, vol. 9, no. 2, pp. 69–76, 2000.