



# Increasing the Traction Properties of Locomotives for the Account of Improvement of Body and Bogies Connexions

Juraj Gerlici<sup>1</sup>, Kateryna Kravchenko<sup>1\*</sup>, Mykola Gorbunov<sup>2</sup>, Tomas Lack<sup>1</sup>

<sup>1</sup>University of Zilina, Slovak Republic

<sup>2</sup>Volodymyr Dahl East Ukrainian National University

\*Corresponding author E-mail: kkatherina@ukr.net

## Abstract

The article presents the results of a research of the reserves for the realization of tractive and braking forces of a rail vehicle. Two target functions have been developed that show the evaluation of the design and identify opportunities to increase the efficiency of using the locomotive. On the basis of the objective functions, technical solutions have been proposed and patented in the crew part of the locomotive. The analysis of the factors that affect the traction and coupling qualities of the locomotive was carried out. A mathematical modeling of the starting from the place of the shunting locomotive TEM103 was carried out. The redistribution of loads from wheel pairs to rails is shown depending on the speed. The change in the wheel-rail contact area when the load of the shunting locomotive TEM103 changes is estimated. The work of the proposed finish loading device in different modes of operation is described. Efficiency of work is shown.

**Keywords:** bogies, locomotive, wheel-rail contact.

## 1. Introduction

The main trend of growth in world trade and foreign trade activities of the CIS countries is an increase in the volumes and speed of the transportation process, an integral part of which is the shunting work. At station maneuvers, not less than 25% of the entire locomotive fleet is occupied, which constitutes a significant part of the fixed assets of railways [1, 2]. In recent years, steadily increasing the number of transportations and the amount of shunting work has significantly increased. Insufficient supply of railway lines with traction vehicles for shunting operations leads to their replacement at the stations by powerful mainline locomotives, which is not economically profitable. According to the research data the fleet of shunting locomotives has decreased approximately twice in the last 10 years. However, reconstruction activities in this area are still slow and not comprehensive. In this connection, the most important task of the railway industry is the creation of an economically justified, multifunctional shunting locomotive, as a technical system, the design and traction-braking qualities of which correspond to the world level of transport development.

## 2. Target Functions for Estimating the Realization Reserve of Traction and Braking Force of a Rail Vehicle

In a multi-axle crew, the maximum traction and braking force is limited by the adhesion force of the limiting axle, which is prone to skidding and spinning, which first goes into excess slip mode, while the other wheel pairs do not reach their adhesion maxima, that is, their traction and braking capabilities, and as a result of this, the capabilities of the entire crew are underutilized. This is

due to the uneven wear of wheel pairs, the difference in wheel diameters and static loads, the redistribution of loads from the wheel pair to the rails during braking, the contacting conditions, the difference in the coefficients of vertical and horizontal dynamics for each wheel pair, etc. The high braking power of some wheel pairs also leads to skid, increased contact temperature, reduced safety and increased noise. At minimization of all unfavourable factors the reserve of use of traction and braking force by rail rolling stock will be maximum. Providing the maximum traction force realized by the locomotive is achieved due to the implementation of each wheel pair the maximum traction force. The attainment of the required condition is possible if the maximum slip is to a minimum at all wheel pairs  $\varepsilon_i^{cr} \rightarrow \min$ .

It is proposed to evaluate the effectiveness of the accepting technical solutions with the help of the target function for traction [3]:

$$C_t = \frac{1}{n} \left[ \sum_{i=1}^n \frac{F_{t \max i}}{F_{ad \max i}} \right] = \frac{1}{n} \left[ \sum_{i=1}^n \frac{2M_i(v, \Phi, I, L, R, \Delta_M) \mu \eta_r}{DP_i(\eta_{cl} \eta_{ol}) \psi_i^{\max}(\varepsilon_i^{cr})} \right] \xrightarrow{\varepsilon_i^{cr} \rightarrow \min} 1; \quad (1)$$

$$F_{ad \max i} \geq F_{t \max i},$$

where  $M_i(v, \Phi, I, L, R, \Delta_M)$  is the torque of the TM of an individual wheel pair that depends on the rotational speed  $v$ , the magnetic flux  $\Phi$ , the intensity of a current  $I$  TM, the length  $L$  and the resistance  $R$  of the current leads,  $\Delta_M$  the torque deviation traction motor from the nominal value within the tolerance for its deviation in accordance with GOST2582-81 [4];  $\mu$  is the gear ratio of the traction reducer;  $D$  - diameter of the wheel in the circle of riding;

$\eta_r$  is the efficiency of the traction reducer,  $P_i$  is the vertical load per axle, which depends on the static and dynamic redistribution of loads caused by the structural parameters of the locomotive  $\eta_{ci}$  and the operational factors  $\eta_{oi}$  [5];  $\psi_i^{\max}$  the maximum coefficient of adhesion achieved when critical sliding  $\varepsilon_i^{cr}$ ,  $n$  - the number of axles of the locomotive.

The physical meaning of the objective function of traction (1) is that each wheel pair must realize the maximum possible tractive force in the given conditions of wheel pair interaction with the rail track.

To evaluate the braking system reserves, a target braking function has been developed, which assumes that the difference between the braking force and the clutch force of each wheel pair is minimized:

$$C_b = \sum_{i=1}^n (P_i \psi_i^{\max} - B_i f_i) \rightarrow \min, \quad (2)$$

where  $B_i$  is the force of pressing the brake pad against the wheel,  $f_i$  is the friction coefficient of the pad.

The physical meaning of the objective function of braking is that, depending on the vertical load ( $P_i$ ) and the mechanical-and-physical properties of the "wheel-rail" contact ( $\psi_i^{\max}$ ), it is necessary to regulate the pressure of the brake pad ( $B_i$ ), stabilize the coefficient of friction in the contact "wheel-pad" ( $f_i$ ) due to the temperature regulation in this contact.

Increasing the efficiency of the technical system, its technological advantage is achieved by searching for the optimal solution [5], which, for multi-parameter and multi-criteria systems, is based on a system analysis of operating experience and research aimed at creating new technology.

### 3. Results of the Research

The analysis of publications [6-12] carried out in this work shows that when designing a new rolling stock, the task of increasing the traction and coupling properties with the improvement of their technical and technological characteristics is put forward. This is possible through the development of scientifically sound technical and technological solutions that accelerate scientific and technological progress in the locomotive economy, including with the maximum possible utilization of the coupling weight of the locomotive [13].

The traction-coupling properties of the vehicle largely depend on the operating conditions [14]. Load on the rail is at the same time the most important factor on which the level of static and dynamic impact on the track, wear and the term of permissible operation of rubbing surfaces depend. The depreciation of the rolling stock and railways caused by the uneven redistribution of loads from wheel sets to rails is the cause of significant losses, numerous speed limits, the likelihood of wagons coming off the rails and other consequences.

The aim of the research is a synthesis of increasing the use of the traction weight of locomotive methods for through the use of a controlled multifunctional system for levelling loads from wheel pairs to rails.

Crew parts of the used vehicles and their control systems do not fully realize the potential traction and braking capabilities of the locomotive. One of the main roles here is the factor of changing the static hanging in the process of operation, the dynamic redistribution when the traction force is realized, which increases the inevitable uneven load on the rails from the wheel sets. The fall in the average values of the loads leads to underutilization of the coupling mass of the traction unit and the reduction of the maximum tractive force by the wheel pair being sold.

With a fixed coefficient of adhesion between the wheel pair and the rails, the ratio of the traction force to the maximum possible

will be determined by the coefficient of use of the coupling weight, i.e. the ratio of the load on the rails from the most unloaded  $P_{lim}$  axis to the static load  $P_{st}$  [15]:

$$\eta = \frac{P_{lim}}{P_{st}}. \quad (3)$$

Coefficient of use of the coupling weight is a variable and depends in general on a number of factors - the design of traction motors (TM), their electromechanical characteristics, the magnitude of the initial load from the axis to the rail, the diameter of the wheel, the design of the crew part, the cost of equipment, vertical locomotive dynamics, the operating mode of the locomotive, the state of the track and others [16].

Usually, when assessing the effect of the crew's design on the coupling weight ratio, it is assumed that all locomotive wheel pairs have the same static load and develop the same traction force. The influence of the dynamic factor is excluded. In this case, for locomotives with individual drive of wheel sets, the static coefficient of utilization of the coupling weight  $\eta_{st}$  is expressed by the following relationship:

$$\eta_{st} = \frac{1}{1 + k\psi_o}. \quad (4)$$

Where  $k$  is the coefficient of unloading of the wheel pair under tractive effort in driving conditions with a restriction of the traction force on the clutch,  $\psi_o$  is the coefficient of adhesion between the wheel pair and the rails.

A lot of work by both domestic and foreign authors has been devoted to the study of the causes of this or that redistribution of loads between individual axes, as well as the identification of load equalization methods [6-12, 17-19, 25].

The repair rules allow the difference in the diameter of the locomotive wheels up to 12 mm. In this case, a difference in the torque of the wheel pairs is observed, an increase in the current distribution, relative slip, and a decrease in the traction force over the clutch. For example, at a speed of 40 km/h, the adhesion force is reduced to 7%, from the discrepancy of the wheel diameters to 1% [17, 18]. An analysis of the scientific literature [19-23] suggests that the redistribution of loads is strongly influenced by spring suspension. The unevenness of the static load on wheel pairs of the same axle reaches 10% with different spring rigidity, 5% - due to the error of the weights. To increase the coefficient of use of the coupling weight, a method for controlling the spring suspension of a locomotive was proposed in [20]. In locomotives with a statically indeterminate spring suspension system, it is important to equalize loads between wheel pairs due to the fact that the normal component of the load can vary by 40-50% with oscillations of the clamped locomotive mass and increased friction in the axle-box unit. A significant effect is provided by a freewheeling balanced spring suspension with the possibility of wheel finish loading [16]. This reduces the propensity to spinning the wheels.

According to [19], the change in the coefficient of use of the coupling weight of the first axis of the locomotive depends on the ratio of the stiffness of the second  $c_2$  and the first stage  $c_1$  of the suspension, and also the ratio of the stiffness of the elastic elements of the first  $c_{21}$  and the remaining  $c_2$  of the side supports of the body to the bogie.

The coefficient  $\eta$  increases with increasing rigidity ratios. Thus to increase the coefficient  $\eta$  of the locomotive with the serial design of the interface between the body and the bogies, the stiffness ratio  $c_2/c_1$  and  $c_{20}/c_2$  must be increased. This is achieved by reducing the number of rubber-metal elements in the body support. With a ratio  $c_2/c_1 = 6$ ,  $c_{20}/c_2 = 2$ , the coupling weight  $\eta$  will increase to 2.42 %.

In the process of operation on locomotives, the uneven distribution of the TM is manifested. This leads to a reduction in tractive effort from 0.2% to 1.1% in the hourly mode [18]. This is explained by

the presence of significant tolerances for the difference in the characteristics of the TM, the inability to carry out a qualitative selection of the wheeled-engine blocks in the depot due to the lack of a sufficient repair fund.

Analysis of the influence of various factors and the relationship between the parameters of the motors for current distribution showed that the difference in the characteristics of the TM exerts the greatest influence on the distribution of currents, due to which the difference in currents can reach 17% of the nominal values. The change in the active resistance of the copper conductors of the windings causes an increase in the current difference on 1.5%. The difference in the diameters of bandages in the circles of riding, which is allowed in operation, leads to an increase in current distribution on 8.3%. In addition, fluctuations in the temperature of the field windings occur in a wide range (up to 150 °C), which almost doubles their electrical resistance [18]. To eliminate this phenomenon and to make fuller use of the coupling weight of the locomotive, a schematic diagram of the device is proposed in [18], which allows regulating the currents of individual engines. The active element of the circuit is IGBT-transistors. When the locomotive is operating at the clutch boundary, the device reduces the load current of the front wheel pair engine and replaces the engines of the rear wheel pairs. Thus, the coefficient of utilization of the coupling weight is increased. At high speeds, the contact time between wheels and rails is shortened, the unloading and the relative speed of sliding of the wheel pairs increase, which can cause the formation of spinning. In the process of spinning, the relative sliding speed increases even more, the coefficient of sliding friction decreases, an increasing part of the mechanical energy is expended on the acceleration of the rotating masses, which leads to dangerous spinning.

An increase in the vertical force acting in the wheel-rail contact can be achieved by applying a so-called linear motor, which is mounted in the bogie [24] and creates an electromagnetic longitudinal force. Simultaneously, in connection with the effect of the magnetic field attraction force of the linear motor, an additional vertical force, arises that acts in the wheel-rail contact and, due to the clutch forces, can significantly increase the traction force on the wheel rim.

When the locomotive moves at the limit on the clutch, which can be accompanied by spinning of the limiting axis, the design of the bogies plays a big role in the realization of the maximum traction force.

When spinning all the axes of the locomotive in the range of translational speeds of 1-15 km/h, it is not possible to obtain a coupling factor of more than 0.8. Simulation of a locomotive with various types of bogies allows quantifying the locomotive's realization of the ultimate traction forces for these coupling conditions. The greatest traction force under the same conditions of adhesion can be obtained by using bogies with inclined links, which have a more even distribution of axial loads and, in some cases, avoid the activation of protection against spinning when driving at the clutch limit [25].

The results of the research showed that when using pneumatic cylinders as finish loading devices it is relatively easy to obtain the optimum value of the coupling weight utilization factor. To solve the problem of equalization of axle loads from wheel sets to rails on a modern shunting locomotive TEM103, created at LLC "HC" Luganskteplovoz", a loading device was used, which makes it possible to increase the efficiency of realizing the maximum traction force [26].

The loading device is attached to the frame 1 of the locomotive bogie (Fig. 1). When moving the locomotive from its place with the help of the "Increase the clutch" button located on one of the control panels, the loader is switched on. In this case, air is supplied to the cavity A (Fig.1) of the cylinder 2 with a lid 14 at a pressure of 0.4 MPa, the piston 15 with the rod 3 moves upward, the release spring 16 is compressed. The lever 5, rotating about the axis 12, through the rod 13 and the rollers 8, 9, rests on the slides 10 welded to the frame 11 of the locomotive. With further move-

ment of the piston 15, the force from the rod 3 through the fork 4, the lever 5, the axle 12 and the bracket 6 with the suspension 7 is transferred to the transverse beam of the frame 1 bogie, increasing the load on the wheel pair located on the transverse beam side.

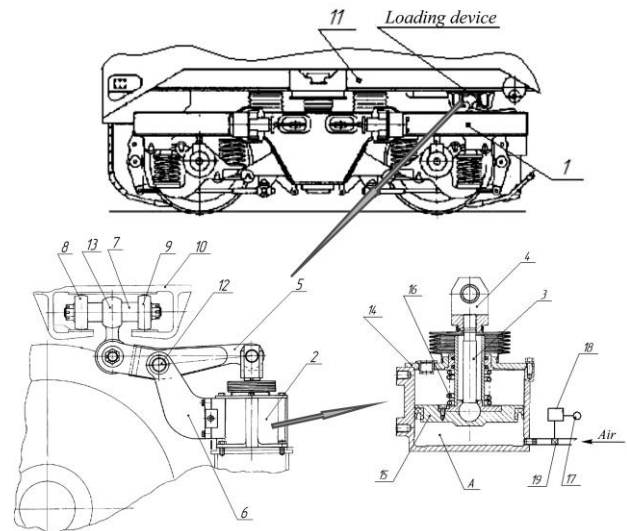

Fig. 1: Scheme of installation of the loading device on the bogie of the shunting locomotive TEM103

When the locomotive reaches a certain speed, a control unit 18 is connected to the speedometer 17. Air is discharged from the cavity A of the cylinder 2 through the solenoid valve 19, and, under the action of the release spring 16, the piston 15 returns to its original position.

For a comparative evaluation of the operation of the shunting locomotive with the loading device and without it, a numerical experiment was carried out. A system of equilibrium equations is constructed on the basis of the distribution of forces acting on the locomotive (Fig. 2) and mass-dimensions (Table 1).

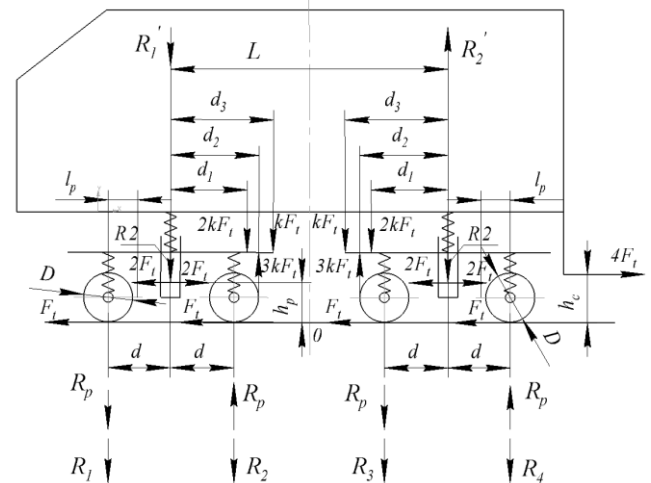

Fig. 2: Diagram of geometric parameters and forces acting on the locomotive.

Table 1: Mass-dimensions parameters of the locomotive TEM103

$L = 8m$	$l_p = 0.979m;$	$R_p = \frac{D}{2l_p} F_t \approx \frac{1.05}{2 \cdot 0.979} \approx 0.54F$
$d = 1.2$	$D = 1.05m;$	
$d_1 = 1.4$	$h_p = 1.45m;$	
$d_2 = 1.1$	$h_c = 1.6m;$	
$d_3 = 1.5$		

1st bogie:

$$\begin{aligned} -R_1 - R_2 + R_1' + 2kF_t &= 0; \\ -R_1d + R_2d - 2R_p d + 2F_t h_p + 3kFd_2 + kFd_3 &= 0; \end{aligned} \quad (5)$$

2nd bogie:

$$\begin{aligned} -R_3 - R_4 + R_3' + 2kF_t &= 0; \\ -R_3d + R_4d - 2R_p d + 2F_t h_p + 3kFd_2 - kFd_3 &= 0; \end{aligned} \quad (6)$$

Body:

$$\begin{aligned} -R_1' + R_2' - 4kF_t &= 0; \\ -R_1' \frac{L}{2} - R_1' \frac{L}{2} - 4F_t h_p + 4kF_t h_c &= 0; \end{aligned} \quad (7)$$

From this system of equations we single out the forces acting on the locomotive, in a general way:

$$\begin{aligned} R_1 &= -1.16kF_t - 0.11851F_t; \\ R_2 &= 1.16kF_t + 0.50601F_t; \\ R_3 &= 1.16kF_t - 0.50601F_t; \\ R_4 &= -1.16kF_t + 0.11851F_t; \\ R_1' &= -2kF_t + 0.3875F_t; \\ R_2' &= 2kF_t + 0.3875F_t; \end{aligned} \quad (8)$$

In this case, the load in wheel pairs will be:

$$\begin{aligned} P_1 &= P_{st} + 1.16kF_t - 0.41775F_t; \\ P_2 &= P_{st} - 1.16kF_t + 0.03025F_t; \\ P_3 &= P_{st} - 1.16kF_t - 0.03025F_t; \\ P_4 &= P_{st} + 1.16kF_t + 0.41775F_t. \end{aligned} \quad (9)$$

Equating  $P_1 = P_3$  we find coefficient of loader  $k$  and coefficient of utilization of the adhesion mass of the locomotive  $\eta$ :

$$\begin{aligned} k &= 0.167 \\ P_1 &= P_{st} + 1.16 \cdot 0.167F_t - 0.41775F_t = P_{st} - 0.024F_t. \end{aligned} \quad (10)$$

$$\eta = \frac{1}{1 + 0.33 \cdot 0.224} = 0.93 - \text{when the loader is on;} \quad (11)$$

$$P_1 = P_{st} - 0.41775F_t. \quad (12)$$

$$\eta = \frac{1}{1 + 0.33 \cdot 0.41775} = 0.88 - \text{when the loader is off.} \quad (13)$$

It follows from the calculation that the use of the loader on the TEM103 locomotive allows to increase the coefficient of use of the coupling weight by 5%.

With a coefficient of adhesion  $\psi = 0.33$ , tangential tractive effort has the following meaning:

$$F_t = P_{st} \cdot \eta \cdot \psi = 220.725 \cdot 0.93 \cdot 0.33 = 67.74 \text{ kN}. \quad (14)$$

The strength in the loader is:

$$kF_t = 0.167 \cdot 67.74 = 11.31 \text{ kN}. \quad (15)$$

The traction force when starting off:

$$F = 4 \cdot F_t = 4 \cdot 67.74 = 270.96 \text{ kN}. \quad (16)$$

The forces in wheel pairs ( $P_i$ ) at a speed  $V = 3$  km/h with the loaders switched on and off are shown in the graph (Fig. 3), from which it follows that when the locomotive is moved from its place and acceleration, the wheels of the first axis are most unloaded, the wheels of the rear axle are loaded, and the values of the vertical loads of the remaining wheels lie in the gap between the extreme values. Fig. 4 shows the coefficients of use of the coupling weight ( $\eta$ ) for the most unloaded wheel pairs, from the analysis of which it follows that at a speed of  $V \leq 11$  km/h, the loader is switched off by the release spring.

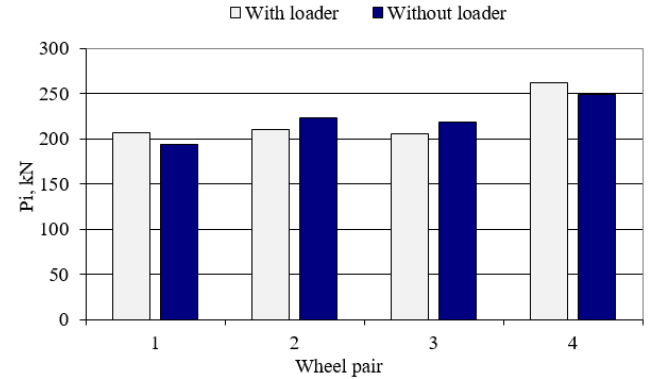

Fig. 3: Efforts in wheel pairs at a speed  $V = 3$  km/h.

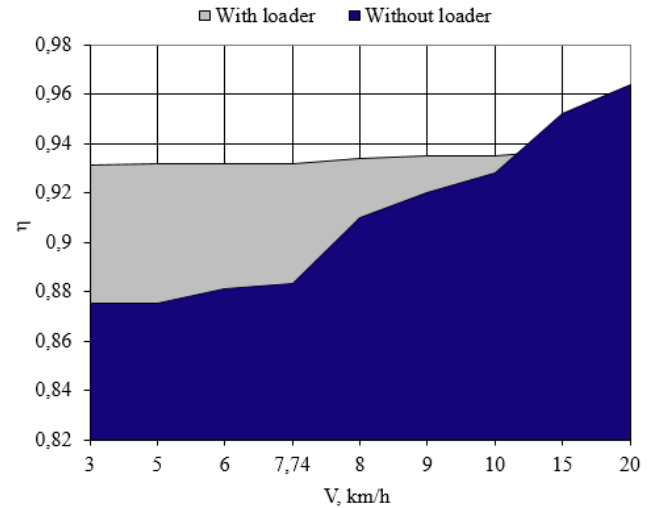

Fig. 4: The change in the coefficient of use of the coupling weight ( $\eta$ ) of the first wheel pairs from the speed ( $V$ )

The implementation of the maximum tractive force determines the operation of the locomotive at the limit of adhesion, it is important that the overload on the axes is minimal. Because, the better the weight of the locomotive is distributed along the axes, the less it is necessary to regulate the traction force.

One of the reasons for the uneven distribution of loads along the axes of wheel sets, except for the tipping moment when the traction is realized, is the deviation from the center of the pivot pin, i.e. skewing of the body as a result of uneven wear of the side supports of the body, or inoperability of the returning device. It is known that during operation, there is also a decrease in the ability of elements of the spring suspension system to extinguish shock loads caused by loss of spring stiffness, springs and other causes (mechanical damage, etc.). This leads to uneven distribution of the load from the wheels to the rails and to limiting the traction force of the locomotive over the clutch. Such a state of spring suspension in the park of locomotives reduces the carrying capacity of the line [12].

Calculations show that the redistribution of loads with the increase in speed on the first in the course of the movement of the wheel pair with the loader on and off is shown in Fig. 5.

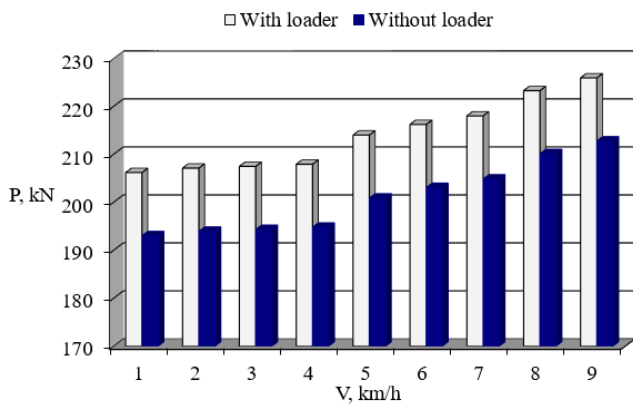

Fig. 5: Dependence of changes in loads Q on the first wheel pair on the speed of movement

#### 4. Evaluation of the Change of the Wheel-Rail Interaction Parameters

The change in load from wheel pairs to rails leads to a change in the area of the contact spot and the distribution of normal stresses along it. It is of particular interest to identify the effect of loaders on contact parameters.

For this purpose, POISK and NZD programs were developed at the Department of Railway Transport of the Vladimir Dahl East-Ukrainian National University using Fortran 2008 [3].

Using the POISK program, the coordinates of the points of the initial touch of the wheel pair with the rail track were determined. The obtained coordinates became the initial data for the NZD program, designed to construct the initial gap function and the iterative solution of the normal contact problem. All calculations were made for the non-undersized profile of the wheel of the shunting locomotive TEM103 according to GOST 5236-2005.

Table 2: Modeling the contact spot of the wheel pair of the shunting locomotive TEM103

№ of wheel-set	Load from wheel to rail, kN			Contact spot area, mm <sup>2</sup>			Contact pressure, MPa			Maximum contact pressure, MPa		
	Without loader	Taking into account operational factors	With loader	Without loader	Taking into account operational factors	With loader	Without loader	Taking into account operational factors	With loader	Without loader	Taking into account operational factors	With loader
1	96	88	103	231	211	239	423	426	440	630	620	650
2	110	112	103	249	253	243	449	451	436	660	650	650
3	111	110	116	253	251	262	449	447	450	660	650	670
4	125	132	119	271	281	265	469	478	457	700	680	680

Table 2 and Fig. 6 show the results of calculating the normal task for the first wheel pair of the shunting locomotive TEM103, taking into account the change in the vertical load from the action of the loaders. The angle of rotation of the wheel pair relative to the rail track is 0°, the lateral displacement is 0 mm, and the vertical load from the first wheel along the rail is 103 kN. Fig. 6a shows the distribution of specific pressures across contact cells, the maximum of which for a given contact is 650 MPa. The shape of the contact spot is shown in Fig. 6b. The results of the calculation are summarized in Table 2.

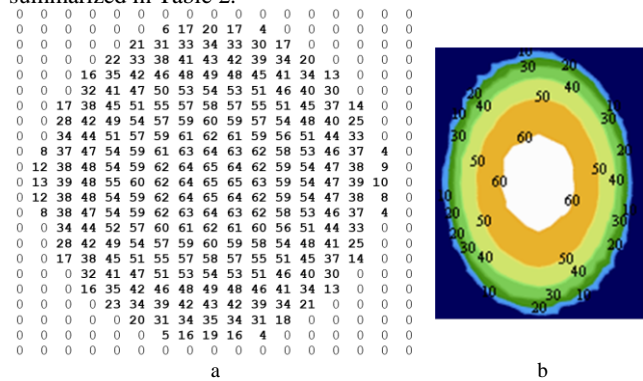

Fig. 6: Distribution of contact pressures, kgf/mm<sup>2</sup>: a - in numerical form (based on the calculation results in the NZD program); b - in a contour form (processing of results of calculations in the program environment MathCad)

Analysis of the data in Table 2 shows that with an increase in the vertical load from 88 kN to 132 kN, the contact spot area increases from 211 mm<sup>2</sup> to 281 mm<sup>2</sup>, with the average specific pressure increasing from 426 MPa to 478 MPa, the maximum pressure from 620 MPa to 680 MPa.

The negative influence of operational factors on contact parameters was noted. For the first wheel pair, the area of the contact spot is reduced to 9%. In turn, the use of loading devices for the first wheel pair makes it possible to increase the contact area to 12.83%.

#### 5. System of Loads Redistribution under Different Operating Conditions.

As a result of mathematical modeling, it was found out that the difference in vertical loads along the axes (Fig. 7) of the second bogie has a significant value. To eliminate such an unfavorable phenomenon, the authors proposed a complex controlled system (CCS) for the redistribution of loads from wheel pairs to rails, which is a system of loading devices 1, 2, 3, 4 (Fig. 8) mounted on the frame of the bogie and control system 5.

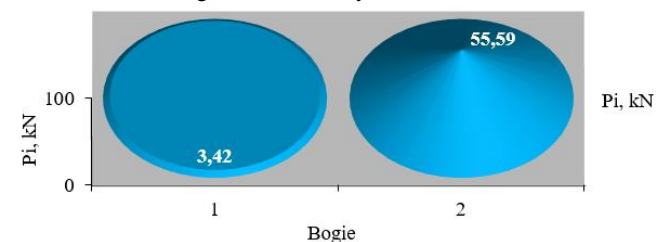

Fig. 7: Difference of vertical loads  $\Delta P_i$  along  $i$ -th axes of bogies of diesel locomotive TEM103

Depending on the driving mode and operating conditions, the control system changes the functionality of the loading devices. In the traction mode, the loaders of the second and fourth axles of the bogies are switched on, whilst loading the first and third axles. To increase the braking efficiency during braking, the loaders of the first and third axles of the bogie are activated, while loading the second and fourth wheel pairs that have been unloaded. On the coastline, the CCS operates in the mode of the vibration damper, and in the curves redistributes the load on the sides of the truck, thereby increasing the tractive, braking, dynamic qualities of the shunting locomotive and the efficiency of fitting the curve sections of the track.

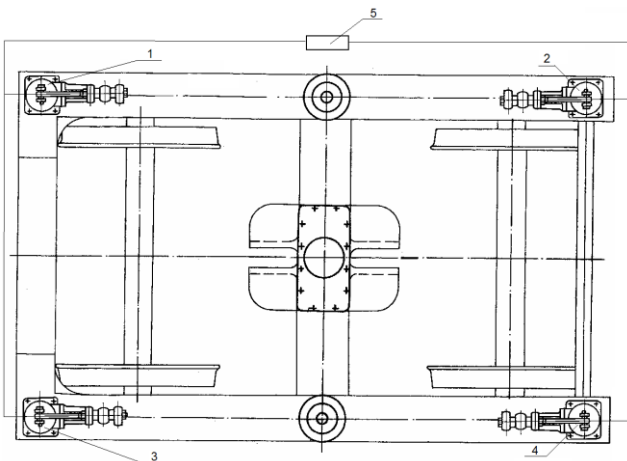

Fig. 8: Scheme of placing the CCS on the locomotive bogie

## 6. Conclusion

The most common measures to increase the value of the realized traction force is to regulate the stiffness ratios of the first and second stages of suspension, the use of inclined links in connection with the bodies with bogies. The research results suggest that the most effective method to increase the utilization rate of the locomotive traction weight is the installation of an integrated controlled system for changing loads on the locomotive wheel pairs in various driving conditions based on the operation of loading devices. Installation of loading devices on a modern diesel locomotive TEM103 allows increasing the coefficient  $\eta$  by 5%. The use of a highly effective integrated control system on locomotives increases the tractive and dynamic qualities of a locomotive in the case of traction, coasting, braking and insertion into curved sections of the track.

## Acknowledgement

The work was supported by the Cultural and Educational Grant Agency of the Ministry of Education of the Slovak Republic in project No. KEGA 077ŽU-4/2017: Modernization of the Vehicles and Engines study program.

## References

- [1] Falendysh A.P. (2006), Development of scientific foundations for determining the characteristics of promising shunting diesel locomotives. Author's abstract. Dis ... Candidate tech Sciences, Kharkiv, 41 p.
- [2] Voronko V.A. (2005), Justification of the choice of the parameters of shunting and industrial diesel locomotives taking into account operating conditions / Author's abstract. Dis. ... cand. tech. Sciences, Moscow, 16 p.
- [3] Kravchenko K.O. Justification of reserves for increasing the traction qualities of a locomotive and their implementation by sliding control in the wheel system with a rail. author's abstract. dis ... t. N. : 05.22.07 - Lugansk: - 2010. - 23 p.
- [4] GOST 2582-81 (1983), Electric rotating traction machines. General specifications. Date of enactment: 01/01/1983, 35 p.
- [5] Gorbunov NI, Kostyukovich AI, Kravchenko EA, Fesenko AI (2010), Increase of efficiency of operation of traction rolling stock, Scientific news from the University of Dahlia Electronic scientific professional edition. №1, Access mode: [http://www.nbu.gov.ua/e-journals/Nvdu/2010\\_1/10gnitps.htm](http://www.nbu.gov.ua/e-journals/Nvdu/2010_1/10gnitps.htm).
- [6] Dižo J., Steišūnas S., Blatnický M. (2017), Vibration Analysis of a Coach with the Wheel-flat Due to Suspension Parameters Changes. 12th International Scientific Conference Of Young Scientists On Sustainable, Modern and Safe Transport, TRANSCOM 2017. Slovakia. Volume 192, 107-112.
- [7] Lack T., Gerlici J. (2013), Wheel/rail contact stress evaluation by means of the modified strip method. *Komunikacie*. Volume 15. Issue 3, 126-132.
- [8] Smetanka L., Štastniak P., Harušinec J. Wear research of railway wheelset profile by using computer simulation. MATEC Web of Conferences. 22nd Slovak-Polish Scientific Conference on Machine Modelling and Simulations, MMS 2017. Sklene Teplice, 2017. Volume 157, Article number 03017.
- [9] Zharov IA, Samme OG, Kurtsev SB, Voronin IN (2002), Dependences of the adhesion coefficient of a wheel-rail pair on contact parameters, friction and wear, No. 6. 611-618.
- [10] Zharov I.A. (2001), Checking the adequacy of models of friction and wear on spots of contact between wheels and rails, *Friction and wear*, No. 5, 487-495.
- [11] Chichinadze AV, Brown ED, Bushe NA et al. (2001), Foundations of tribology (friction, wear, lubrication), Textbook for Technical Universities, Moscow, Mashinostroenie, 664 p.
- [12] Lyashenko V.V. (2006), Alignment of loads of electric locomotive wheels on rails in conditions of current repair, Author's abstract. Dis. ... cand. tech. Sciences, Samara, 135 pp.
- [13] Zharov IA, Kurtsev S.B. (2003), On the algorithms for controlling the antiskid devices of a train, *Vestnik VNIIZhT*, No. 2, 27-30.
- [14] Kurbasov A.S., Kurbasov B.A. (2004), Traction capabilities of electric locomotives can be improved, *Lokomotiv*. № 5, 24 - 25.
- [15] Konyaev AN, Spiriyagin I.K. (1971), Ways to improve the traction qualities of diesel locomotives 2TE10L, *Sat. "Locomotive engineering"*, vol. 3, 19-24.
- [16] Gorbunov NI, Kashura AL, Popov SV, Kravchenko EA, Fesenko AI (2008), Ways of solving the problem of increasing the traction qualities of locomotives, *International Information and Scientific and Technical Journal "Lokomotivinform"*, No. 5, 8 - 11.
- [17] Deev VV, Ilin GA, Afonin GS (1987), *Draft of trains*, Moscow: Transport, 264 p.
- [18] Gorobchenko O.M. (2007), Improvement of traction characteristics of locomotives by increasing the coefficient of use of coupling mass. Author's abstract. Dis ... Candidate tech Sciences, Kharkiv, 17 p.
- [19] Vykhlyayeva N.V., Gorbunov N.I. (1984) On the effect of the rigidity of the body supports on the use of the coupling mass of the locomotive, construction and the trans-fleet. cars out 16, 41-45.
- [20] Andreev AA (1980) Features of traction and dynamical qualities of a locomotive with elastic longitudinal conjugation of a body and trolleys, Author's abstract. Dis ... Candidate tech sciences Dnipropetrovsk, 24 p.
- [21] Tkachenko V., Sapronova S., Kulbovskiy I., Fomin O. (2017), Research of resistance to the motion of vehicles related to the direction by railway, *Eastern-European Journal of Enterprise Technologies*, Vol. 5, Issue 7 (89), P. 65–72. doi: 10.15587/1729-4061.2017.109791
- [22] Hauser V., Nozhenko O., Kravchenko K. and others (2017). Proposal of a Steering Mechanism for Tram Bogie with Three Axle Boxes. *Procedia Engineering*, Vol. 192, 289-294.
- [23] Galliev II, Nekhaev VA, Nikolaev V.A. (2005), Quasiinvariant spring suspension of the freight wagon, *Railway transport*, No. 11, 28-30.
- [24] Concept of electric traction with linear booster (2004), *Railways of the world*. № 8, 13-16.
- [25] Fedyayev V.N. (2006) Influence of the electric and mechanical subsystems of the main diesel locomotive on the realization of the ultimate tractive effort, Author's abstract. Dis. ... candidate of technical sciences, Bryansk, 18 p.
- [26] Gorbunov MI, Kashura OL, Kravchenko K.O. and others (2009), The loading device, the Patent of Ukraine №87915, 25.08.2009, *bullet*. No. 16, 4 pp.