

Smart traffic management system with real time analysis

Sheena Mariam Jacob^{1*}, Shobha Rekh¹, Manoj G¹, J. John Paul¹

¹ Department of Electronics & communication Engineering, Karunya University

*Corresponding author E-mail: johnpaul@karunya.edu

Abstract

This paper aims to overcome traffic congestion caused by ineffective traffic management systems that are outdated and work on a predefined countdown. These traditional systems allot timings irrespective of the actual density in traffic on a specific road thereby causing large red light delays. The system we propose ensures traffic lights respond to real time values of traffic, thereby allowing proper management of time and resources. In order to do this we first calculate the density of traffic which is determined using a combination of ultrasonic sensors and image processing techniques. This information is processed by a Raspberry Pi, which in turn controls the traffic light indicators. In addition to that, the data that is collected is sent to the cloud, and can be used to monitor traffic flow at periodic intervals. In case of sensor system failure, the values stored in the cloud will also be useful in predicting the density of traffic based on long term periodic analysis.

Keywords: Cloud; Image Processing; Raspberry Pi; Traffic Congestion; Ultrasonic Sensors

1. Introduction

In today's world where technology has transcended all barriers it has now become easy to solve most human problems and one of these problems include traffic congestion. Traffic congestion has increased drastically over the years and has had negative impacts that include road rage, accidents, air pollution, wastage of fuel and most importantly unnecessary delays. One of the many causes of traffic congestion is improper traffic management systems.

The first gas lit traffic light was invented in London in the 1860's to control traffic caused by horse carriages in the area and it was operated manually by police officers. Since then traffic lights have adapted so as to allow the smooth movement of traffic. The electric traffic light came soon after in the early 1900's, and this was later replaced by the automated traffic lights which are still used in a number of cities today. This system works like clockwork with the lights changing at regular intervals, but soon people realized that the system had a flaw. In many occasions vehicles had unnecessary waiting periods because the light would be red even when the opposite road was empty.

The main purpose of this paper is to introduce a system which will allot time to each road based on the amount of traffic[1]. The amount of traffic on a single lane is classified under three levels: low, medium and high. These levels are determined by the Raspberry Pi based on inputs received from the ultrasonic sensors and camera. Based on the level of traffic the Raspberry Pi then allots timings for a lane, and makes changes to the red, green and yellow indicators. In addition these values processed by the Raspberry Pi are sent to the cloud where they can be stored and accessed whenever required. Also, if the level of traffic indicated by the image processing techniques and ultrasonic sensors continuously differ then the previous values stored on the cloud can be used to determine the level of traffic for that specific time till the required repairs are made.

This traffic management system fulfills its duty by enabling the smooth movement of vehicles and it also has a fail-safe system which will prove useful in unexpected circumstances.

2. Literature Review

A number of papers have been published with an aim to overcome the disadvantages of the traditional traffic light system. The various methods use to find the density of traffic can be classified based on vehicle detectors such as piezoelectric sensors and Inductive Loops[2], Ultrasonic Sensors[3], Infrared Sensors[4] and sound Sensors[5], Acoustic Sensors[6], Video/ Image processing techniques[7]-[9], RF based detectors[10], Fuzzy Logic Systems[11] and systems based on cloud computing and IoT[12],[13].

This paper uses a combination of techniques so as to provide results that are more accurate.

3. Methodology

a) Block Diagram

The main components of traffic management system as shown in Fig 1 include a camera, the yellow, green and red indicators, the IOT platform for analytics - ThingSpeak and the ultrasonic sensors. The ultrasonic sensors and the camera serve as input devices, the indicators as output devices, and the Raspberry Pi as the edge device that is used to communicate with the cloud.

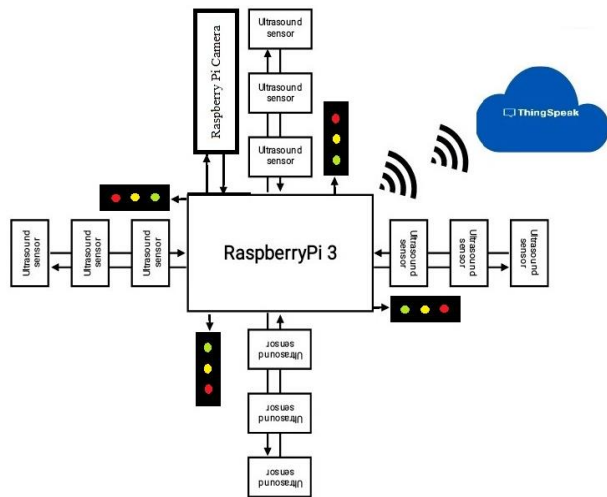

Fig. 1: Block Diagram.

b) Working:

The main purpose of the smart traffic managements system is to allot timings to a traffic signal based on the level of traffic on a lane. In order to calculate the level of traffic on each lane the road is divided into three equally spaced sections. These sections are labeled L0, L1, and L2 as shown in Fig 2.

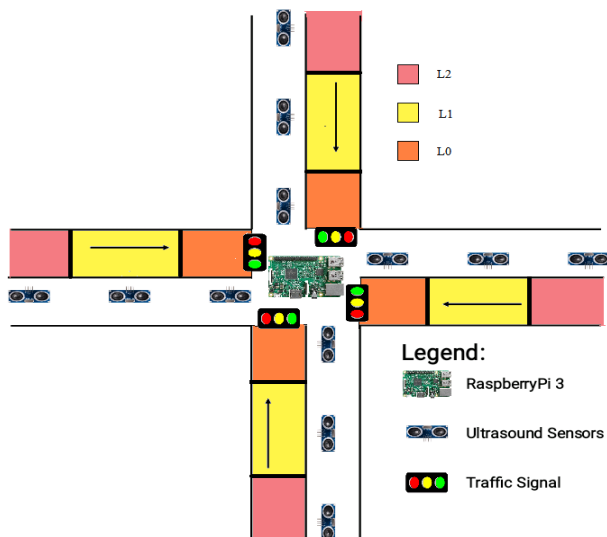

Fig. 2: Schematic Diagram Showing the Different Section L0, L1, and L2.

Each section houses an ultrasonic sensor to determine if vehicles are present in that particular area. The ultrasonic determines the presence of an obstacle by finding the distance taken for a transmitted signal to be received. In addition a camera is placed at the junction who takes images of the lane at periodic intervals. Using image processing techniques, the image of an empty road is cropped into the three sections. The mean value of this empty road is compared against cropped images of the actual road to find the level of traffic in the area. Based on the vehicles present in a section the level of traffic is classified as low, medium and high as portrayed in the table below.

Table 1: Traffic Levels Based on Presence of Vehicles (P) In Various Sections

Level Of Traffic	L0	L1	L2
Low Level	P	X	X
	X	P	X
	X	X	P
Medium Level	P	P	X
	X	P	P
	P	X	P
High Level	P	P	P

The ultrasonic sensors and the results from the image processing techniques are sent to the Raspberry Pi and based on the inputs received the Pi calculates the level of traffic and accordingly allots the time to the traffic indicators. These values processed by the Raspberry Pi are further sent to the IOT platform (ThinkSpeak) where they can be stored in the form of a database useful for analyzing traffic density patterns in a particular area.

In addition, the Raspberry Pi compares the values provided by both the ultrasonic sensors and image processing results to make sure the level of traffic is the same in both the cases. If there appears to be a large variation in readings on multiple occasions then the values stored on ThinkSpeak provide sufficient data to run the traffic lights in the absence of the sensor system. This does not provide accurate results, but the timing allotted to the traffic lights are based on previous levels of traffic calculated over an extended period of time. So saying the above mentioned system has a fail-safe system that can be used in case of failures too.

4. Results

The results obtained are based on the prototype as shown in Fig.3 of a four way traffic junction. The ultrasonic sensors used in the prototype is the HC-SR04 as portrayed in Fig 3.1



Fig. 3: HC-SR04 Ultrasonic Sensor.

These sensors can be used to determine the presence of an obstacle which in our case is vehicles. Each lane houses three sensors which are placed at equal distances and are positioned vertically at the divider. For the four roads a total of 12 ultrasonic sensors are used. These sensors are connected to the Raspberry Pi using jumper wires and the information collected by the sensors is processed by Raspberry Pi.

The Raspberry Pi camera module portrayed in Fig 4 serves as to capture Real time traffic images. These images are processed using Python Image Library (PIL) and Numpy libraries-supporting large multidimensional arrays and matrices.



Fig. 4: Raspberry Pi Camera Module.

The Pi then determines the level of traffic and allots timing to the traffic light indicators which are the red, yellow, and green LED's.

Fig 5 shows the setup of the prototype housing the camera module, the Raspberry pi, the ultrasonic sensors and the traffic light indicators.



Fig. 5: Four Way Traffic Junction Prototype.

Fig. 6 portrays how the ultrasonic sensors determine the level of traffic. As shown in the figure, the densities on Road 1,2,3,4 are respectively low, medium, no traffic and high. The corresponding values displayed on the python terminal confirm that the sensors read the same values.



Fig. 6: Output at Python Terminal for the Corresponding Levels of Traffic.



Fig. 7: Shows Four Different Images Captured by a Camera with the Corresponding Output from the Image Processing Algorithm.

Every time the Raspberry Pi finds the level of traffic it updates the values to ThinkSpeak. On the ThinkSpeak platform the values that are sent can be stored in the form of a graph as shown in Fig 8. Allowing the channel to be made public gives access to anyone who would like to view the level of traffic at a specific junction thereby enabling users to be well informed of the traffic density in a region. In addition these values can be converted in the form of a database using the data export option, which will also serve as a source of information of traffic levels. This data can be made useful in case

the sensor system fails by finding the average density of traffic at specific time slots.

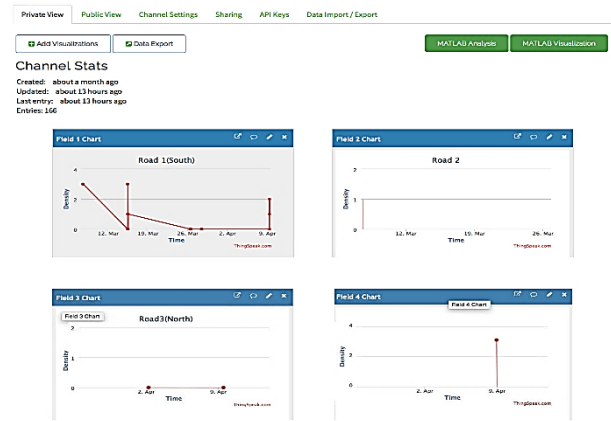

Fig. 8: Graphical Representations of Traffic Levels on the ThinkSpeak Platform.

Therefore from the above results it can be inferred that together with the help of ultrasonic sensors and image processing techniques an approximate level of traffic can be found out that is equivalent to real time values of traffic. This information gathered can be used to assess and control the traffic lights in real time depending on actual densities of traffic. This will intern help in saving time and reducing the negative effects of traffic congestion.

5. Conclusion

This system configuration reduces huge traffic queues caused by the conventionally implemented system used in many places. The system also additionally reduces the workload of officers who would have to direct traffic in unexpected situations, or when the traffic lights are not responding. It also enables traffic lights to work continuously with less chances of malfunctioning. The system in simple words provides a simple yet effective solution to improper traffic management systems.

6. Future scope

This project still has space for improvement and can be extended by displaying traffic data in an application that can be accessed by the public. In addition the system can be made more efficient by using a camera with higher resolution or by replacing the HC-SR04 ultrasonic sensors with industrial grade sensors that serve the same purpose. Further changes can also be made to the system that permits emergency vehicles to be given the highest priority in any situation [14].

Acknowledgments

This project is funded and supported by Karunya Institute of Technology and Sciences (KITS).

References

- [1] Author "Title of the Paper", *Journal name*, Vol. X, No. X, (200X), pp. XX-XX, available online: <http://xxx>, last visit:28.02.2013
- [2] Author, "Title of the Paper", *Proceedings of the conference name*, Vol. X, No. X, (200X), pp: XX-YY, <http://dx.doi.org/10.1109/MMM.2013.2248651>.
- [3] Author, *Title of the Book*, Publisher, (200X), pp: XXX-YYY.
- [4] Cho JH, Chang SA, Kwon HS, Choi YH, KoSH, Moon SD, Yoo SJ, Song KH, Son HS, Kim HS, Lee WC, Cha BY, Son HY & Yoon KH (2006), Long-term effect of the internet-based glucose monitoring

system on HbA1c Reduction and glucose stability: a 30-month follow-up study for diabetes management with a ubiquitous medical care system. *Diabetes Care* 29, 2625–2631.

- [5] Fauci AS, Braunwald E, Kasper DL & Hauser SL (2008), Principles of Harrison's Internal Medicine, Vol. 9, 17th edn. *McGraw-Hill*, New York, NY, pp.2275–2304.
- [6] Kim HS & Jeong HS (2007), A nurse short message service by cellular phone in type-2 diabetic patients for six months. *Journal of Clinical Nursing* 16, 1082–1087.
- [7] Lee JR, Kim SA, Yoo JW & Kang YK (2007), The present status of diabetes education and the role recognition as a diabetes educator of nurses in Korea. *Diabetes Research and Clinical Practice* 77, 199–204.
- [8] McMahon GT, Gomes HE, Hohne SH, Hu TM, Levine BA & Conlin PR (2005), Web-based care management in patients with poorly controlled diabetes. *Diabetes Care* 28, 1624–1629.
- [9] Thakurdesai PA, Kole PL & Pareek RP (2004), Evaluation of the quality and contents of diabetes mellitus patient education on Internet. *Patient Education and Counseling* 53, 309–313.