

Performance analysis of facts devices for reduction of power quality issues in DFIG based WECS integrated to grid

M. Rama Sekhar Reddy^{1*}, Dr. M. Vijaya Kumar²

¹ Research Scholar, Department of EEE, JNTUA, Andhra Pradesh, India

² Professor, Department of EEE, JNTUA, Andhra Pradesh, India

*Corresponding author E-mail: ramasekharreddy.eee@jntua.ac.in

Abstract

Integration of a wind farm with electric grid is an issue that has gained interest due to poor power quality and unmatched power and frequency of grid. Maintenance of power quality has become an important factor in modern power systems. The usage of non-linear loads results in various power quality events which over a period would reduce life and deteriorate the performance of end user equipment. FACTS devices are available that use power electronic components provide efficient solutions for improving power quality in Distribution systems. This paper discusses performance of three FACTS devices SSSC, DSTATCOM and UPQC for mitigating voltage sags, swells and harmonics injected into a DFIG based WECS. The model is developed on MATLAB/ SIMULINK platform and results are presented.

Keywords: DFIG (Double Fed Induction Generator); Grid; Power Quality; Voltage sag, Voltage Swell; reactive power compensation; Wind Turbine; SSSC (Static Synchronous Series Compensator); DSTATCOM (Distribution Static Synchronous Compensator); UPQC (Unified Power Quality Conditioner).

1. Introduction

Over the past few decades due to industrialization and urbanization, the need, usage and demand for electrical energy has increased drastically. But generation of adequate power to meet the growing demand is still a problem due to limited resources available. Deposits of fossil fuels have gradually decreased over years and now are at the edge of depletion. Also these fuels have resulted in a pollution that caused many adverse effects on the environment. This led to looking for other options such that electricity can be generated from inexhaustible and pollution free renewable sources. Eventually usage of natural resources including sun, wind, ocean waves have gained importance [1]. Though the installation costs are high, these plants based on renewable energy sources are non pollutant. Compared to other plants, wind energy conversion system requires less maintenance cost and is economical. WECS used in

Conjunction with fixed speed generator systems and properly controlled by power electronics circuitry would harvest considerable amount of electrical energy. These systems also offer better power quality by mitigating events such as flickers, voltage sags, swells, harmonics etc.

Synchronous generators are a best choice for WECS in producing electric power with constant frequency. However, these systems require a static frequency converter as it is necessary to synchronize the system with the grid. Other approach for achieving constant frequency electric power is by a DFIG based wind energy conversion system. The stator of Stator of DFIG is connected to the grid and its rotor forms a closed loop control by connecting the machine to the grid through a pair of power electronic converters which in turn are connected to each other via a common DC link. This type of construction would obtain electric power with constant frequency [2]. In fixed speed operation of DFIG, the disturbances in the wind would cause large voltage fluctuations on the grid. For variable speed applications, DFIG provides efficient control of active and

reactive powers by usage of power electronic converters. The required reactive power for DFIG is provided either by the mains or the capacitors that locally generate reactive power [3]. As the speed of the wind is not constant and is unsteady most of the time, the mechanical speed also tends to change. Depending on the type, nature and intensity of disturbances in the wind, the wind farm either demands or injects active or reactive power in to the grid. This results in change in the terminal voltage due to which power quality events appear in the waveforms. Voltage sags, swells, flickers, harmonic distortion, voltage phase unbalances, transients are some common power quality issues experienced by a WECS.

These power quality issues propagate through the transmission lines and feeders and will cause detrimental effects on the connected loads. Some effects that are caused are overheating, equipment malfunction, interference with electric and magnetic fields, increase in losses thus reducing the life and efficiency of consumer equipment. These disturbances also have negative effects on the wind farm thus allowing it to be less efficient.

Traditional practice is to improve the short circuit power level at PCC such that other connected loads will be free from power quality disturbances. PCC is a point at either the primary or secondary of a service transformer to which number of loads are connected. Thus, a better option is to connect a FACTS device at PCC which would filter out the variations and protect the sensitive loads [5]. FACTS devices combine power electronic control technology for absorbing or injecting capacitive and inductive power into the network such that necessary voltage regulation can be achieved by mitigating power quality disturbances to a level prescribed by IEEE standards.

2. System description and modeling

2.1. System description

Fig.1 shows the test system considered to study the effectiveness of FACTS devices in mitigating power quality issues in a DFIG based WECS. The system is considered to comprise two parallel transmission lines. As shown in Fig.1 capacitive, RLC and non-linear loads are fed by first line for different intervals of time. These loads result in a voltage swell, sag and harmonics respectively in the system. This line is also affected by a three phase fault besides the varying loads. These issues also effect second transmission line which comprises of DFIG based WECS. Power quality issues that occur in second line due to the loading effects in first line will deteriorate the performance of DFIG based WECS. Thus it is necessary to protect second line from the adverse effects of power quality events that occur in first line.

In order to overcome these affects suitable facts devices are connected at the Point of Common Coupling. In this paper different types of facts controllers such as Static synchronous series compensator (SSSC), Distribution Static Compensator (DSTATCOM) and Unified Power Quality Conditioner (UPQC) devices are used to overcome voltage sag, voltage swell and harmonics injected into the network.

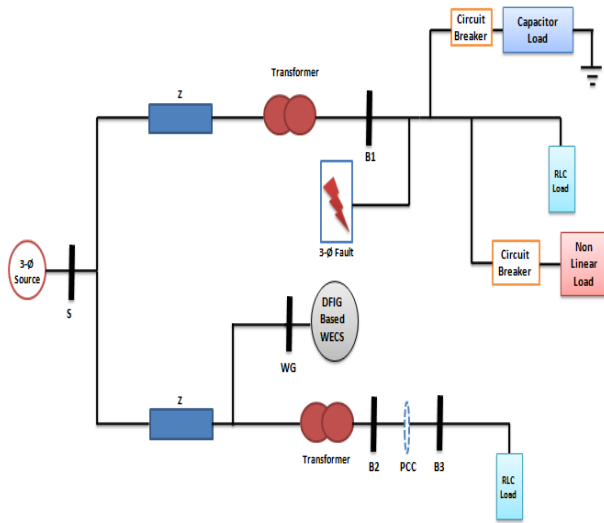

Fig. 1: Single Line Diagram of Study Case Power System.

2.2. Dynamic modeling of WECS:

The wind power developed by the turbine is given by the equation (1)

$$P_m = \frac{1}{2} \rho C_p(\lambda, \theta) A_r V_w^3 \quad (1)$$

Here C_p is the power coefficient. It can be calculated by using the following equation.

$$C_p(\lambda, \beta) = 0.73 \frac{151}{\lambda_i} - 0.58\beta - 0.002\beta^{2.14} - 13.2 e^{-\frac{18.4}{\lambda_i}} \quad (2)$$

Where

$$\lambda_i = \frac{1}{\frac{1}{\lambda - 0.02\beta} - \frac{0.003}{\beta^3 + 1}} \quad (3)$$

And

$$\text{TSR}(\lambda) = \frac{\omega_r R_r}{V_w} \quad (4)$$

2.3. Double fed induction generator modeling

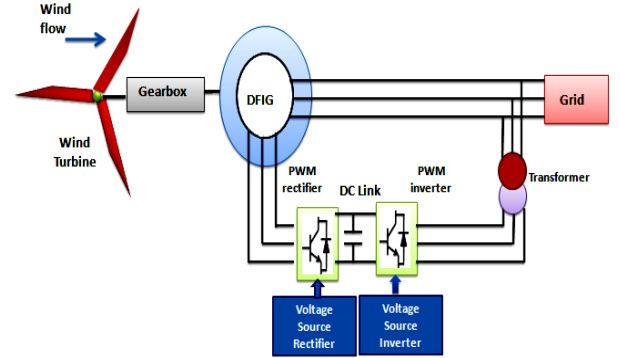

Fig. 2: Wind Energy Conversion System with DFIG.

The structure of DFIG fed Wind Energy Conversion system is shown in Fig. 2. The power from the wind is extracted to maximum extent and fed to the electric grid by employing power electronic converters. Stator of the wound rotor induction machine is connected to the low voltage side of three-phase grid. Rotor of DFIG is connected to the grid through a pair of back-to-back connected voltage source converters. These converters act in tandem as rectifier and inverter during the conversion process and are connected by a common DC link as shown in Fig.2. This combination of AC/DC/AC converters with DC link is connected to the grid by means of a transformer so that the output voltage of the converter matches with the grid voltage. Voltage Source Rectifier provides suitable excitation to the rotor and employs vector control for the control of active and reactive powers on stator and rotor sides of DFIG. Voltage Source inverter permits the system to be operated in both sub-synchronous and super synchronous speeds thus controlling power flow between DC link and its output AC side. DFIG provides motor and generating modes of operation in both sub synchronous and super synchronous speeds. However only two generating modes of sub synchronous and super synchronous speeds are used for application in wind power generation [4].

It is necessary to track optimum torque- speed curve for obtaining desired values of speed and torque. Speed can be adjusted to the desired value by controlling torque. So an active power set point is chosen from instantaneous value of rotor speed. This information is further used to regulate the rotor current in stator flux-oriented reference frame. Thus desired speed and torque are obtained. Further reactive power set point can also be calculated from active power set point using a desired power factor [6].

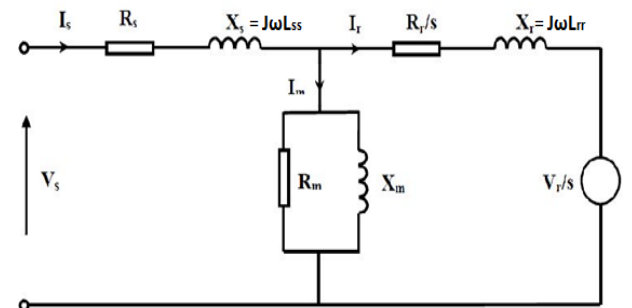

Fig. 3: Equivalent Circuit of DFIG.

The equivalent circuit of the DFIG is shown in Fig.8. From the fig the following equations are used for design of DFIG.

$$V_{ds} = R_s i_{ds} + \frac{d\psi_{ds}}{dt} - \omega_s \psi_{qs} \quad (5)$$

$$V_{qs} = R_s i_{qs} + \frac{d\psi_{qs}}{dt} + \omega_s \psi_{ds} \quad (6)$$

$$V_{dr} = R_r i_{dr} + \frac{d\psi_{dr}}{dt} - (\omega_s - \omega_r) \psi_{qr} \quad (7)$$

$$V_{qr} = R_s i_{qr} + \frac{d\psi_{qr}}{dt} + (\omega_s - \omega_r)\psi_{dr} \tag{8}$$

The ψ stands for flux linkage and express as:

$$\psi_{ds} = L_{ss} i_{ds} + L_m i_{dr} \tag{9}$$

$$\psi_{qs} = L_{ss} i_{qs} + L_m i_{qr} \tag{10}$$

$$\psi_{dr} = L_{rr} i_{dr} + L_m i_{ds} \tag{11}$$

$$\psi_{qr} = L_{rr} i_{qr} + L_m i_{qs} \tag{12}$$

And also

$$L_{ss} = L_s + L_m \tag{13}$$

$$L_{rr} = L_r + L_m \tag{14}$$

3. Designing of compensating facts device models

The dynamic compensation of voltage variations is performed by injecting voltage in series and active-reactive power at the Point of common coupling (PCC) at bus 2. This is accomplished by using, different FACT devices connected at the PCC. In this paper SSSC, STATCOM and UPQC devices are used.

3.1. Control strategy of SSSC

Static Synchronous Series Compensator (SSSC) is a FACTS device which is mostly used to compensate voltage during fault conditions. Operation being similar to STATCOM, it is also known as series STATCOM except that STATCOM is a shunt connected device but SSSC is connected in series to a transmission line. SSSC is basically a combination of a VSC, a coupling transformer and a power supply as shown in Fig.4. This device is connected to a transmission line through the coupling transformer [7].

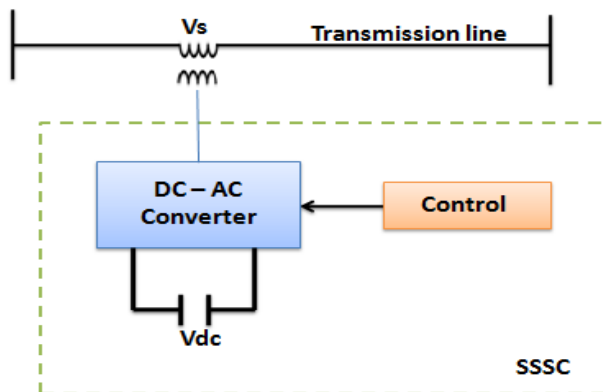

Fig. 4: Schematic Diagram of SSSC.

The voltage injected by SSSC will lead or lag the transmission line current with a phase shift of and thus allows consistent control of voltage. The injected voltage is of equal magnitude but out of phase with the voltage across transmission line.

SSSC provides three modes of operation- normal, capacitive and inductive modes. The effect of transmission line reactance is controlled by series voltage injection. Thus the injected voltage represents a capacitive or inductive reactance which in turn influences power flow in the transmission line [6]. When voltage injection by SSSC results in capacitive reactance, the effective reactance is decreased and flow of active and reactive power is increased. Thus

positive reactance compensation is achieved. But when voltage injection by SSSC results in inductive reactance, the effective reactance is increased and flow of active and reactive power is decreased. Thus reactance compensation is achieved in negative direction.

When an efficient and sophisticated control method is used SSSC can also provide power factor correction and reduce harmonics by active filtering.

3.2. Control strategy of D-statcom

D-STATCOM is a widely used custom power device that compensates reactive power, regulates voltage sag and swells conditions, improves power factor and mitigates harmonics at distribution voltage level. D-STATCOM circuitry comprises of a Voltage Source converter and a capacitor for energy storage. This circuit is controlled by a suitable controller that dictates the functionality of VSC by continuously measuring magnitude and phase angle of the D-STATCOM output voltages. Thus D-STATCOM absorbs or generates active or reactive power and provides appropriate compensation during power quality disturbances [8]. D- STATCOM is connected to the transmission line by means of a coupling transformer as shown in Fig.5.

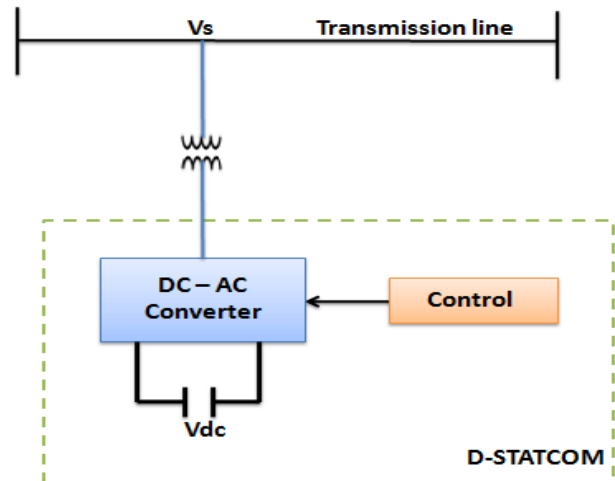

Fig. 5: Schematic Diagram of D-STATCOM.

3.3. Control strategy of UPQC

Unified Power Quality Conditioner is a custom power device which is also named as Universal Active filter. The objective of UPQC is to protect the critical loads connected to PCC against harmonics, voltage disturbances such as sags, swells, unbalances, voltage fluctuations (flicker), provide voltage regulation and to direct the reactive power flow. Structure of UPQC comprises of both series and shunt compensators connected via a common DC link as shown in Fig.6. Series compensator is a SSSC connected to the transmission line by means of a transformer and operates as Voltage Source Inverter [10]. This converter when controlled accurately will compensate harmonic, provide harmonic isolation and damp harmonic oscillations. Other converter is a shunt connected D-STATCOM which operates as a Current Source inverter. This converter provides compensation for waveform distortions that occur due to harmonics and other voltage imbalances. This also regulates voltage to desirable level. Thus both voltage and current compensation is provided by series and shunt connected power electronic converters [9].

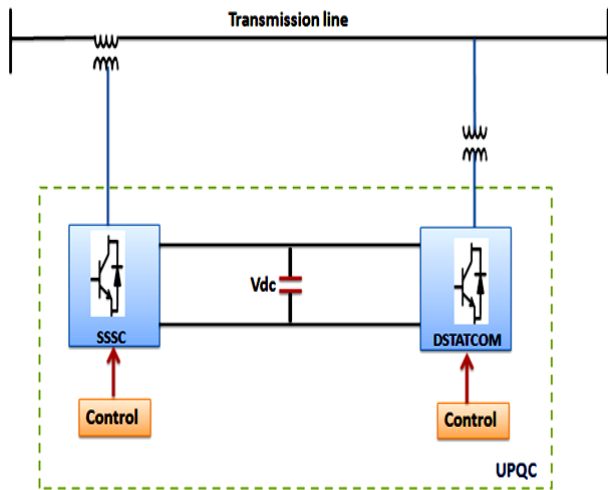

Fig. 6: Schematic Diagram of UPQC.

4. Result analysis

4.1. Test system without any facts devices

Fig.7depicts the MATLAB/SIMULINK model of the test system considered. Initially the performance of the system is observed without providing any compensation. So no FACTS devices are connected to the system as shown. The power system network consists of two parallel transmission lines. As observed in Fig below the first transmission line experiences a three phase fault. The time interval of fault occurrence is set from 0.3 to 0.5 sec during which voltage sag occurs.

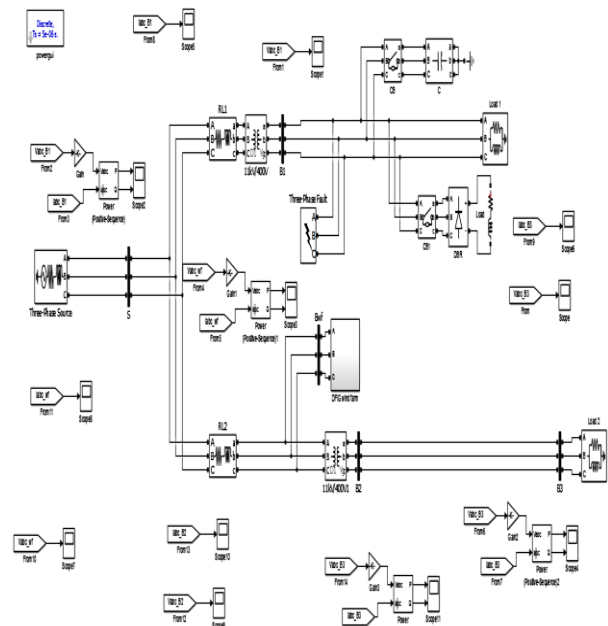

Fig. 7: MATLAB/SIMULINK Model for Test System.

The addition of a capacitive reactance to the first transmission line during the time interval 0.7 to 0.9 sec results in a voltage swell. Also the non-linear load connected to the first transmission line injects harmonics into the network due to its non-linear nature. Time interval during which non-linear loads gets connected to the system due to which harmonic currents are injected is from 1.1 to 1.3 sec. Second transmission line consists of DFIG based WECS as shown in Fig.7. Power quality issues taking place in first transmission line also effect second line as these are supplied by the same source. Thus because of the changes taking place in the first transmission line, second line suffers from three different power quality issues i.e. sag, swell and harmonics.

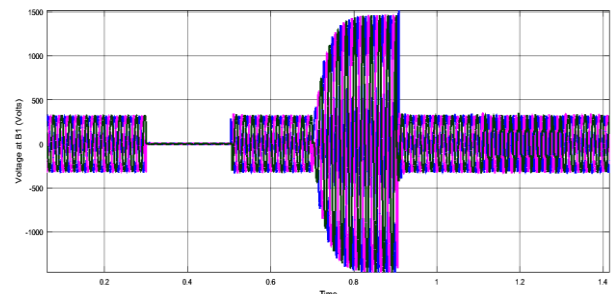

Fig. 8: Voltage Waveform at B1 Point.

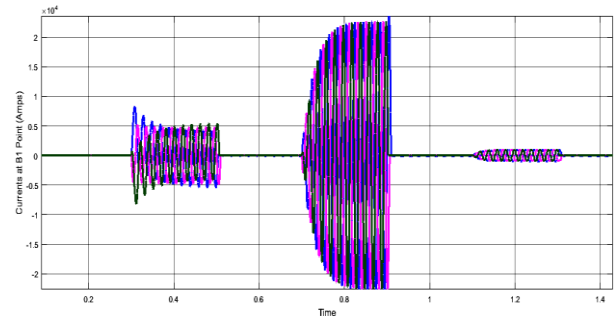

Fig. 9: Current Waveform at B1 Point.

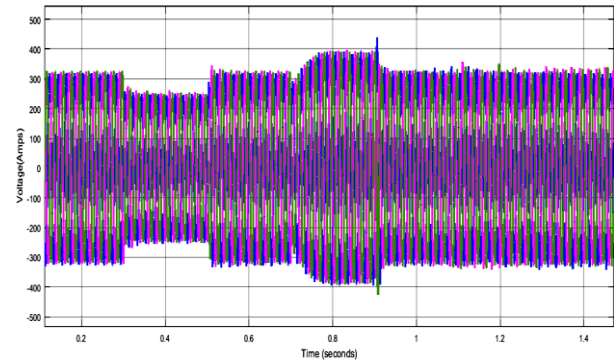

Fig. 10: Voltage Waveform at B3 Point.

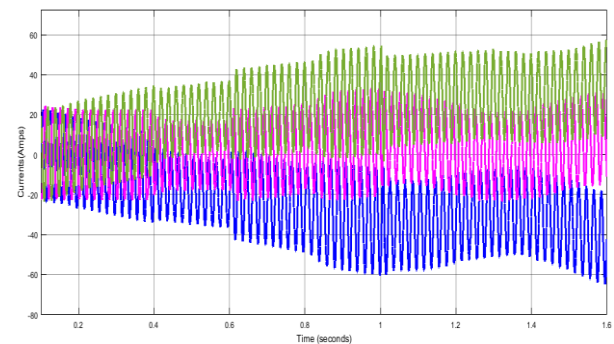

Fig. 11: Current Waveform at B3 Point.

The corresponding voltage and current wave forms of first line observed at point B1 are as shown in Fig.8 and Fig.9. The voltage and current wave forms of line 2 at load point B3 are as shown in Fig.10 and Fig.11 from which it can be observed that the voltage and current waveforms of second line are distorted due to power quality issues that first line has experienced.

From Fig.10, it can be noticed that voltage sag is created during 0.3sec to 0.5 sec with a voltage decrease from 380V to 270V. Voltage swell is obtained during 0.7 sec to 0.9sec with a increase in voltage from 380V to 410V and waveform is distorted due to harmonics during the time period 1.1 sec to 1.3 sec. These power quality issues can be compensated by connecting custom power devices such as SSSC, DSTATCOM and UPQC devices at PCC point.

4.2. MATLAB/SIMULINK model for static synchronous series compensator (SSSC)

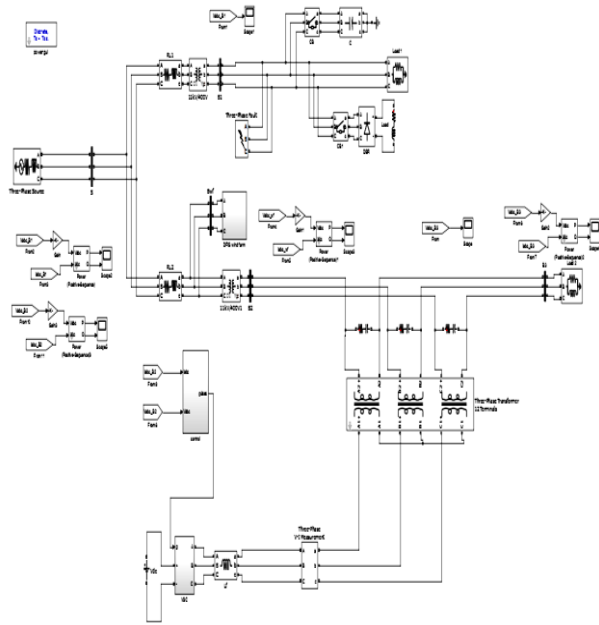

Fig. 12: MATLAB/SIMULINK Model for SSSC Connected at Point PCC in the Test System.

Fig.12 shows the MATLAB/SIMULINK Model for the test system where SSSC is employed for compensation. As seen in Fig.12 SSSC is connected at the PCC point in the second line of the test system in order to reduce the power quality issues at the load point. The second line is also employed with DFIG based WECS to supply the required active and reactive powers at the load point. Fig.13 and Fig.14 show the voltage and current wave forms at the load B3 point. From these figures, it can be observed that Static Synchronous series compensator (SSSC) compensates the voltage and current wave forms at the load point. Fig.15 shows that required active and reactive powers of 10MW and 5MVar are supplied by DFIG machine at the load point B3.

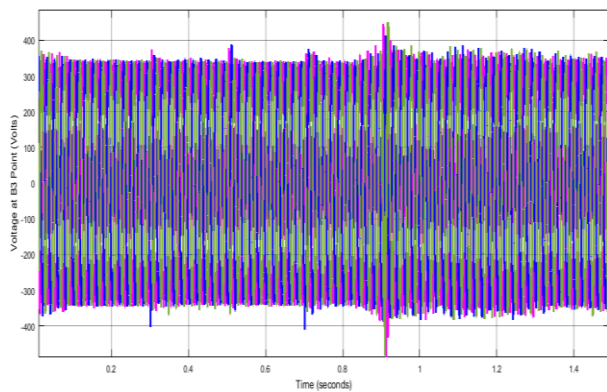

Fig. 13: Voltage Waveform at B3 Point.

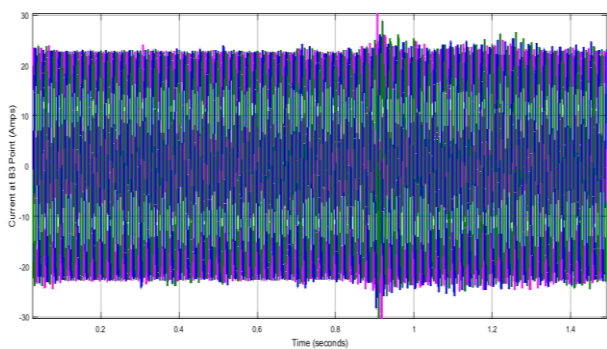

Fig. 14: Current Waveform at B3 Point.

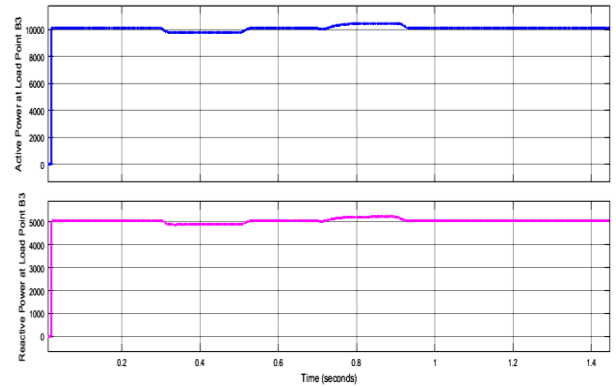

Fig. 15: Active and Reactive Power at B3 Point.

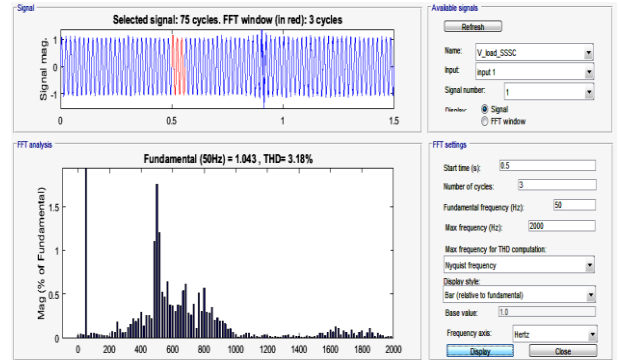

Fig. 16: Harmonic Spectrum of Load Voltage at T = 0.5sec (for Sag Condition).

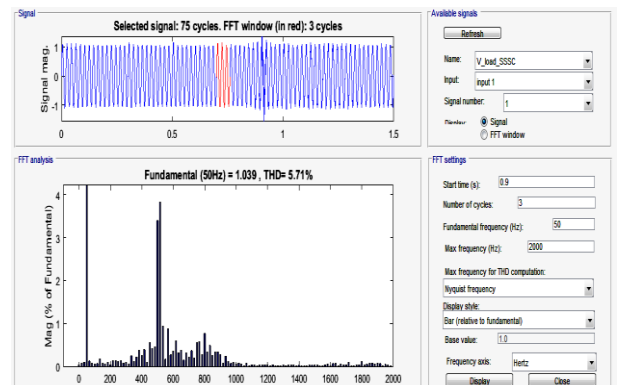

Fig. 17: Harmonic Spectrum of Load Voltage at T = 0.9sec (for Swell Condition).

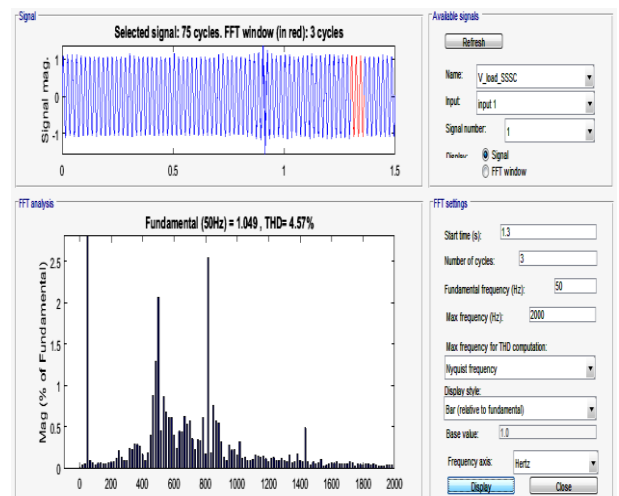

Fig. 18: Harmonic Spectrum of Load Voltage at T = 1.3 Sec (for Harmonics Caused Due to Non-Linear Load).

Fig.16, Fig.17 and Fig.18 show the harmonic spectra of load voltage (B3 point) at different time instants. %THD at $t = 0.5$ sec (Voltage sag harmonic) is 3.18%, at $t = 0.9$ sec (Voltage swell harmonic) is 5.71% and at $t = 1.3$ sec (harmonics) is 4.57% respectively. 4.3 MATLAB/SIMULINK Model for Distribution Static Compensator (D - STATCOM):

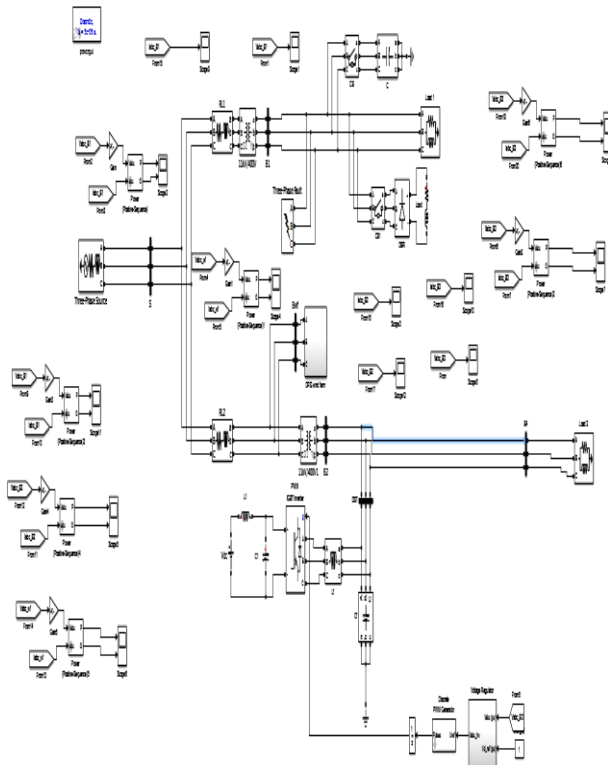

Fig. 19: MATLAB/SIMULINK Model for D - STATCOM Connected at Point PCC in the Test System.

Fig.19 shows MATLAB/SIMULINK model for test system employed with DSTATCOM for compensation. DSTATCOM is connected at PCC point in the second line of the test system. Fig.20 and Fig.21 show voltage and current wave forms at load B3 point and it can be observed that DSTATCOM has satisfactorily compensated sag, swell and harmonics produced due to disturbances occurred in first transmission line. Fig.22 shows that required active and reactive powers of 10MW and 5MVar are supplied by DFIG machine at the load point B3.

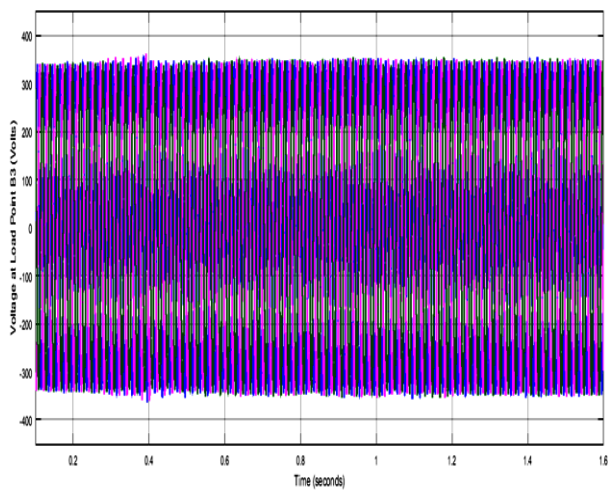

Fig. 20: Voltage Waveform at B3 Point.

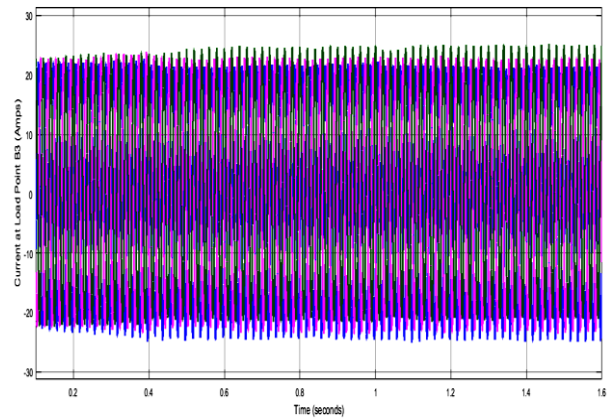

Fig. 21: Current Waveform at B3 Point.

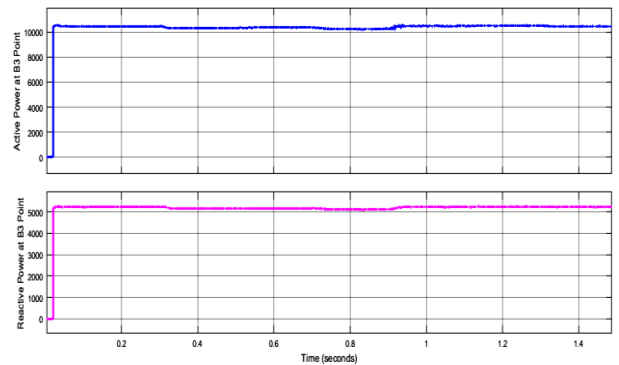

Fig. 22: Active and Reactive Power at B3 Point.

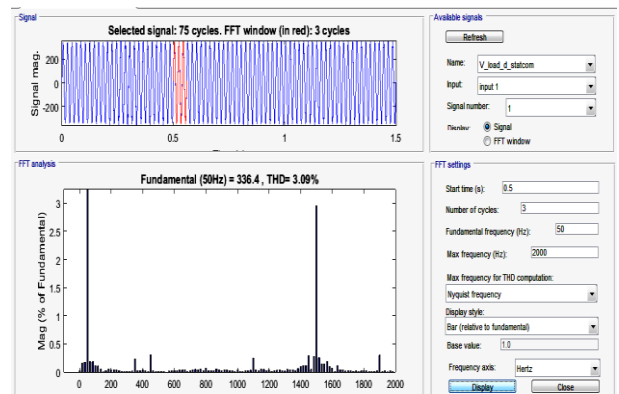

Fig. 23: Harmonic Spectrum of Load Voltage at $T = 0.5$ Sec (for Sag Condition).

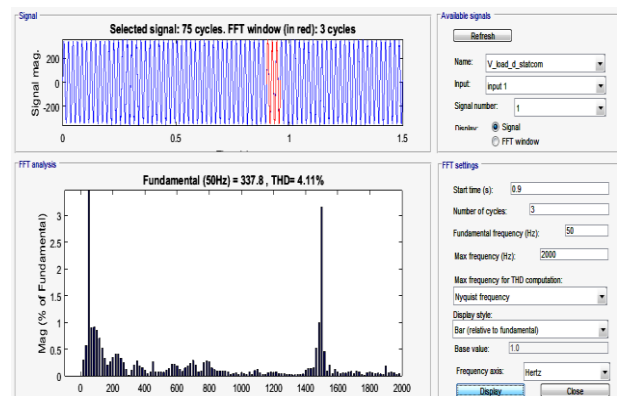

Fig. 24: Harmonic Spectrum of Load Voltage at $T = 0.9$ sec (for Swell Condition).

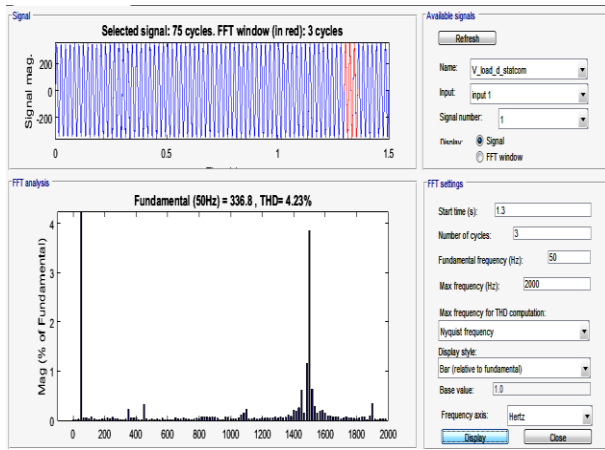

Fig. 25: Harmonic Spectrum of Load Voltage at T = 1.3 Sec (for Harmonics Caused Due to Non-Linear Load).

Fig.23, Fig.24 and Fig.25 show the harmonic spectra of load voltage (B3 point) at different time instants. %THD at t = 0.5 sec (Voltage sag) is 3.09%, at t = 0.9 sec (Voltage swell) is 4.11% and at t = 1.3 sec (harmonics) is 4.23% respectively.

4.4. Mat lab/Simulink model for unified power quality conditioner (UPQC)

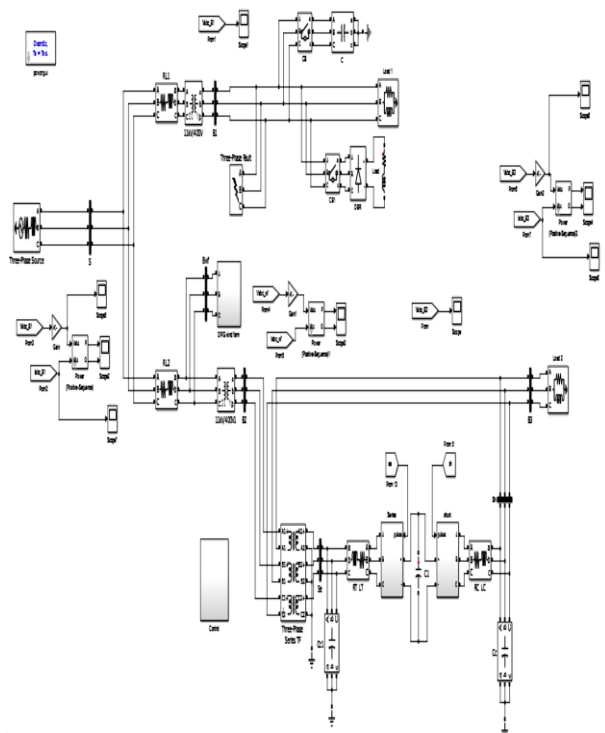

Fig. 26: MATLAB/SIMULINK Model for UPQC Connected at Point PCC in the Test System.

Fig.26 shows MATLAB/SIMULINK model for system employed with UPQC at PCC point of second line for compensation. Fig.27 and Fig.28 show voltage and current waveforms at load point B3 and it can be observed that UPQC has satisfactorily compensated voltage sag, swell and harmonics. Fig.29 shows that required active and reactive powers of 10MW and 5MVar are supplied by DFIG machine at the load point B3.

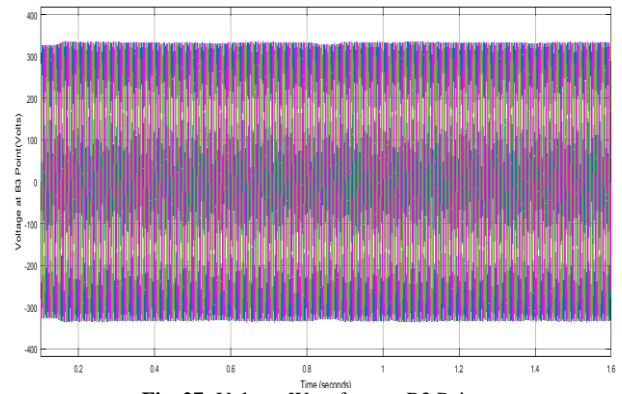

Fig. 27: Voltage Waveform at B3 Point.

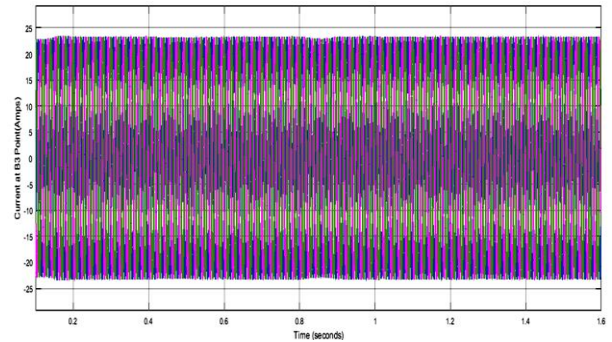

Fig. 28: Current Waveform at B3 Point.

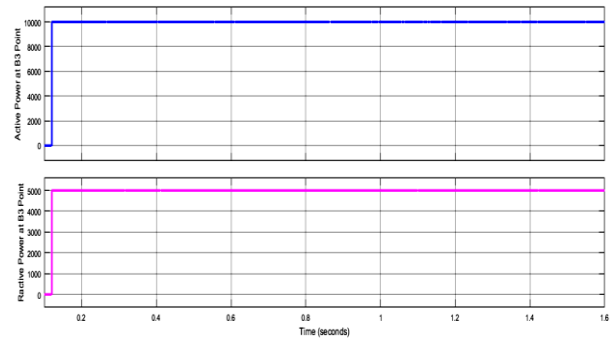

Fig. 29: Active and Reactive Power at B3 Point.

Fig.30, Fig.31 and Fig.32 show the harmonic spectra of load voltage (B3 point) at different time instants. %THD at t = 0.5 sec (Voltage sag harmonic) is 2.145, at t = 0.9 sec (Voltage swell harmonic) is 2.20% and at t = 1.3 sec (harmonics due to non-linear load) is 2.19% respectively.

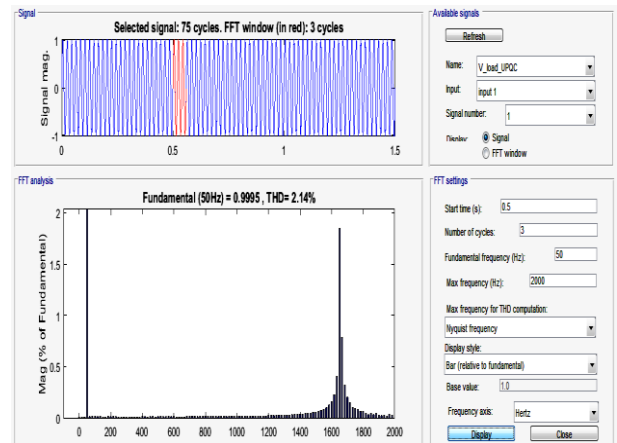

Fig. 30: Harmonic Spectrum of Load Voltage at T = 0.5Sec (for Sag Condition).

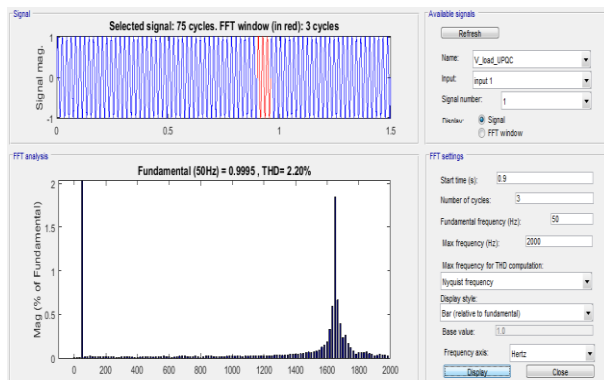

Fig. 31: Harmonic Spectrum of Load Voltage at T = 0.9sec (for Swell Condition).

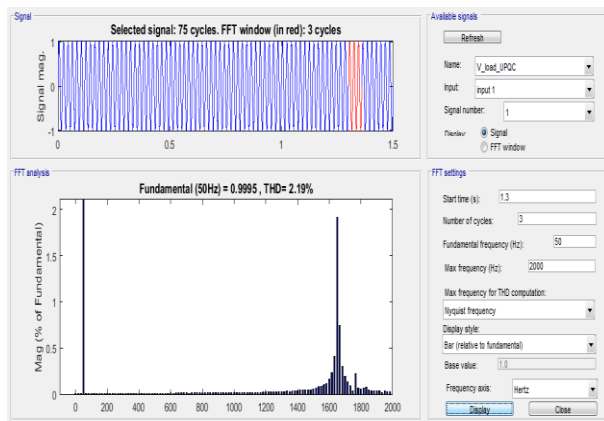

Fig. 32: Harmonic Spectrum of Load Voltage at T = 1.3 Sec (for Harmonics Caused Due to Non-Linear Load).

4.5. Comparative analysis

% THD	SSSC	D-STATCOM	UPQC
% THD for V_{load} at t = 0.5 sec	3.18%	3.09%	2.14%
% THD for V_{load} at t = 0.9 sec	5.71%	4.11%	2.20%
% THD for V_{load} at t = 1.3 sec	4.57%	4.23%	2.19%

% THD values of the voltage waveforms at load point B3, when measured at various instants representing different power quality issues are given in Table.1. The harmonic distortions values obtained from various compensating devices are compared. SSSC results in percentage THD of 3.18%, 5.71% and 4.57% at the instants t=0, t=0.5, 0.9, 1.3 sec respectively. DSTATCOM yields percentage THD of 3.09%, 4.11% and 4.23% at the instants t=0, t=0.5, 0.9, 1.3 sec respectively. UPQC results in percentage THD of 2.14%, 2.20% and 2.19% at the instants t=0, t=0.5, 0.9, 1.3 sec respectively. UPQC is capable of reducing voltage sags, swells and harmonics more efficiently than SSSC and DSTATCOM under various conditions.

5. Conclusion

The performance of FACTS devices SSSC, DSTATCOM and UPQC have been analyzed when a DFIG fed WECS is subjected to sag, swell and harmonic conditions. The voltage waveforms show that these devices are capable of compensating sag, swell and harmonic conditions satisfactorily. The harmonic content is also measured at instants where sag, swell and harmonic have been completely compensated (at t=0.5, 0.9, 1.3 sec) for all the three devices. From simulation results obtained it can be observed that UPQC has better compensation capabilities and reduces harmonic distortion to nearly 2% at various time instants thus meeting the IEEE prescribed standards.

References

- [1] Dr Kondapalli .S.Varaprasad, "Comparison and Analysis on the Role of D-STATCOM and DVR with PI Controller to improve the power Quality in Distributed Networks", International Research Journal of Computer Science (IRJCS), Volume 1, Issue 2, ISSN: 2393-9842, Pp: 1-13.
- [2] Mr. Suhas, M. Shembekar, Mr.Nikhil S.Borse, Mr.Lilachand P Patil "A Comparative Analysis of UPQC for Power Quality Improvement", International Journal of Innovative Research in Advanced Engineering (IJIRAE) ISSN: 2349-2163, Issue 4, Volume 2 (April 2015), Pp: 229-233.
- [3] N. K. Swami Naidu, Member, IEEE, and Bhim Singh, Fellow, IEEE, "Doubly Fed Induction Generator for Wind Energy Conversion Systems with Integrated Active Filter Capabilities", IEEE Transactions on Industrial Informatics, Vol. 11, No. 4, August 2015, and Pp: 923-933.
- [4] Mahesh Chanagond and Plasin Dias, "Implementation of Statcom on Dfig Based Wind Form", International Journal of Science, Engineering and Technology, ISSN (P): 2395-4752, Pp: 539 – 543.
- [5] Miss Sobha Injeti, K. Ratna Raju, "Power Quality Improvement by UPQC device in Doubly Fed Induction Generator Wind Farm to Weak-Grid Connection", International Journal of Scientific & Engineering Research Volume 2, Issue 12, December-2011, ISSN 2229-5518, Pp:1 – 7.
- [6] G. Pandu Ranga Reddy and Dr.M. Vijaya Kumar, "Analysis of Wind Energy Conversion System Employing DFIG with SPWM and SVPWM Type Converters", Journal of Electrical Engineering (JEE) Volume 15, No.4, Sep 2015, Pp. 95 - 106.
- [7] M. Rama Sekhar Reddy and M.Vijaya Kumar, "A Review of Power Quality Issues and Its Mitigating Techniques in Wind Energy Conversion System Integrated To Grid", International Journal of Advancement in Engineering Technology, Management and Applied Science, ISSN: 2349-3224, Volume 05 - Issue 01, January-2018, and PP. 06-16.
- [8] Noramin Ismail and Wan Norainin Wan Abdullah, "Enhancement of Power Quality in Distribution System Using D-STATCOM", the fourth International Power Engineering and Optimization Conference (PEOCO2010), Shah Alam, Selangor, Malaysia. 23-24 June 2010.
- [9] Metin Kesler and Engin Ozdemir, Senior Member, IEEE, "Synchronous-Reference-Frame-Based Control Method for UPQC under Unbalanced and Distorted Load Conditions", IEEE Transactions on Industrial Electronics, Vol. 58, No. 9, September 2011.
- [10] C.H. Ram Jethmalani, V. Karthikeyan, and Narayanappa, "Implementation of UPQC for Voltage Sag Mitigation", International Journal of Computer Communication and Information System (IJCCIS), Vol2. No1. ISSN: 0976-1349 July – Dec 2010.