

Harmonic Analysis of Fuzzy Logic Controller Based Active Filter Unit Using Resonant Current Control in Distributed Power System

Pattabhiram. B, Sai Veerraju. M*

Department of Electrical and Electronics Engineering, SRKR Engineering College, Bhimavaram, Andhra Pradesh, India- 534204

*Corresponding author E-mail: saiveerraju@yahoo.co.in ; Tel +91-9396450021

Abstract

Wide-ranging utilize of nonlinear loads creates harmonic resonance issues in radial distribution system. Harmonic amplification occurring at different locations in the radial line are due to the behavior of active filter as a harmonic admittance rather conductance. This paper presents fuzzy logic controlled active filter by using resonant current control to damp a harmonic resonance. For controlling active filter as an approximately pure harmonic conductance, collections of different parallel band-pass filters are tuned for resonant current controller at harmonic frequencies. A MATLAB/SIMULINK results illustrate that the fuzzy logic controller based active filter improves higher damping performance correlated with alternative techniques.

Keywords: Active filter, fuzzy control, harmonic resonance, harmonic voltage damping, resonant current control.

1. Introduction

With the presence of inductors and capacitors can produce harmonic resonance and this can affect the voltage distortion in radial distribution system [1]-[3]. This is a major impact with wide range of nonlinear loads are presented in the systems [4]. The upper limit of total harmonic distortion (THD) of voltage is 5% and distortion of voltage entity is 3% for the less than 69kV and this is as per the IEEE std. 519-1992 [5].

The harmonic resonance can be damped by using shunt active filter as conductance in radial system [6]. The mismatching among the conductance of active filter and the characteristic impedance of the line could effect in accidental extension of harmonics due to the influence of harmonic signals. This incident is like a “whack-a-mole” enjoyment for children [7]. At the presence of filter equipment, voltage harmonics are damped but in the absence of filter, accidental harmonics are still present. On the feeder, the active filter running as Conductance is capable of mitigation of harmonic Voltage. Though, the active filter presents inductive nature at harmonic frequencies as a substitute of conductance owing to narrow bandwidth of the current control. Different types of current controls are considered for active filters.

An uneven switching frequency can produce lower order harmonics in hysteresis current regulator [12]. In recent times, resonant controls have been applied for the active power filters and compensation of harmonic current is trouble-free at load side [13] and also reduces harmonic voltage circulation [14]. For controlling active filter as an approximately pure harmonic conductance, collections of different parallel band-pass filters are tuned for resonant current controller at harmonic frequencies. In order to maintain the performance of damping with respect to variations in load and system, the realization of separate tuning conductance in [15] for different harmonic frequencies.

2. Active Filter Unit Control Mechanism

An Active Filter Unit (AFU) control mechanism as shown in **Figure 1**. The harmonic resonance can be mitigated by active filter as conductance and it is placed at the end of a radial line. At different harmonic frequencies ω_h , harmonic voltage is determined based on synchronous reference frame (SRF) transformation and its value becomes a dc value after E_{abc} is transformed into the SRF. The low-pass filter (LPF) is used to split the dc value and then the equivalent harmonic component $E_{abc,h}$ is achieved after reverse transformation. Here, a phase-locked loop (PLL) is necessary to find out system frequency for performance of SRF. Assign value of ω_h , as a negative for negative-sequence i.e., 5th harmonic or a positive for positive-sequence i.e., 7th harmonic.

Conductance G_h^* tuning control as observed in **Figure 2**. G_h^* Is obtained, based on VD_h at AFU placing point E_{abc} .

Where harmonic voltage distortion VD_h is given by

$$VD_h = \frac{E_{h,rms}}{E_{rms}} \cdot 100 \quad (1)$$

Where,

$E_{h,rms}$ = rms value of harmonic voltage component E_h

$$E_{h,rms} = \sqrt{\frac{\int_t^{t+T} (E_{a,h}(t)^2 + E_{b,h}(t)^2 + E_{c,h}(t)^2) dt}{T}} \quad (2)$$

E_{rms} = rms value of voltage E

$$E_{rms} = \sqrt{\frac{\int_t^{t+T} (E_a(t)^2 + E_b(t)^2 + E_c(t)^2) dt}{T}} \quad (3)$$

Two LPFs are used to filter out ripples in VD_h derivation at ω_c . To regulate variable G_h^* by controlling error between VD_h^* and VD_h is then fed into a proportional integral (PI) regulator for various harmonic frequencies.

The addition of $i_{abc,f}^*$ and $i_{abc,h}^*$ gives total current.

Here,

$i_{abc,f}^*$ = fundamental current and it is generated by a fuzzy logic to regulate the dc voltage V_{dc} of the AFU

$i_{abc,h}^*$ = all harmonic currents and it are expressed as

$$I_{abc,h}^* = \sum_h G_h^* \cdot E_{abc,h} \tag{4}$$

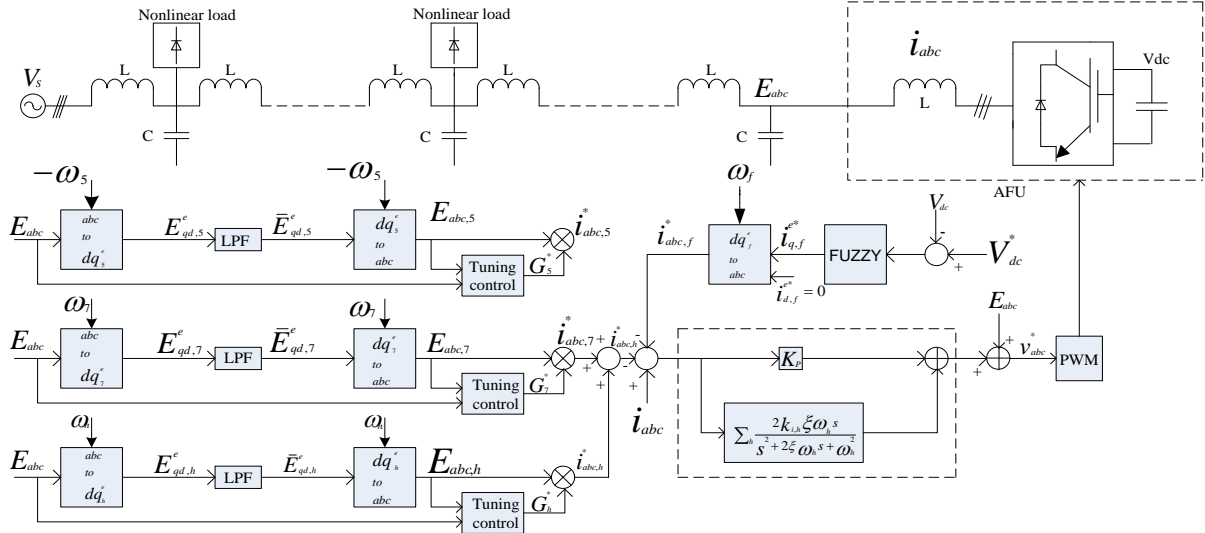

Fig. 1: Control mechanism of active filter unit

Where,

G_h^* = conductance and

$E_{abc,h}$ = harmonic voltage and as shown in Figure 1,

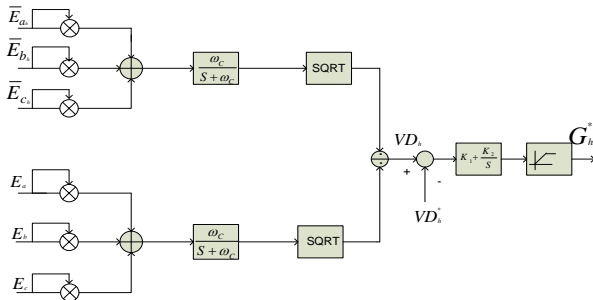

Fig. 2: Conductance tuning control

To mitigate resonance at ω_h by resonant current control is tuned for active filter is given by:

$$T_r(s) = k_p + \sum_h \frac{2k_{i,h}\xi\omega_h s}{s^2 + 2\xi\omega_h s + \omega_h^2} \tag{5}$$

Where,

k_p = proportional gain and

$k_{i,h}$ = is an integral gain for individual harmonic frequency

ξ = damping ratio for selectivity and bandwidth of the current control.

Therefore, to produce the output voltage of AFU by voltage v_{abc}^* is obtained for PWM.

3. Fuzzy logic Controller

Fuzzy logic controller is based on a set of linguistic rules. These rules are determined by the system. The numerical variables are transformed to linguistic variables in fuzzy. The fuzzy contains

Fuzzification, inference engine and defuzzification as shown in Figure 3.

3.1. Fuzzification

Fuzzification is the process of converting a real scalar crisp value into a fuzzy quantity. This is done by assigning six sets to appropriate triangular membership to each input.

3.2. Inference engine

Three types of mechanisms are used to converting input to output of fuzzy based on their rules for fuzzy inference. Here mamdani type min operator implication is used. If the antecedent of a rule has more than one part (more than one input), the fuzzy operator (“min” operator if the connective is “and”, “max” operator if the connective is “or”) is applied for the membership values to obtain the truth value of the rule. This truth value is then applied to the output fuzzy set. A rule base containing rules of the form “rule: If x is A AND y is B then z is C” is implemented.

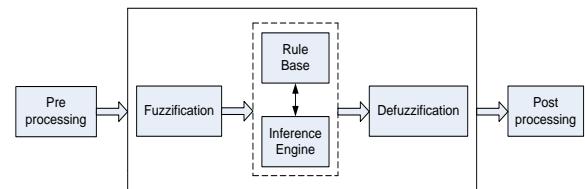

Fig. 3: Fuzzy logic controller

3.2. Defuzzification

The plant requires crisp value, so defuzzification by centroid method is desired for the fuzzy logic controller output, and then fuzzy logic controller output modifies the control output.

4. Study of system simulation

The proposed system is simulated to mitigate harmonic resonance by fuzzy logic controlled active filter by using resonant current control and the system is arranged in a lumped feeder as shown in **Figure 4**. Here, current controller contains 5th and 7th terms because high order harmonics (>7) are clear in the system [2]. The system parameters considered are *Power System*: 3 ϕ , 220 V (line-to-line), 20 KVA, and 60 Hz. Base values are listed in Table 1.

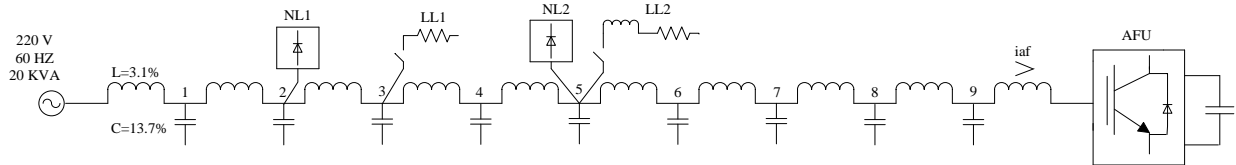

Fig. 4: Simulation circuit configuration

Tuning Control: $k_1 = 100$, $k_2 = 2000$, $\omega_c = 62.8\text{rad/s}$, and voltage distortion for 5th and 7th harmonic: $VD_5^* = VD_7^* = 3\%$. The AFU is implemented by a three-phase voltage source inverter with the PWM frequency 10 kHz

Table.1.: Base values

Voltage base	220V
Current base	52.5A
Impedance base	2.42 Ω
Conductance base	0.413 Ω^{-1}

4.1 Response of Active Filter under Steady State

The response of bus voltages are distorted when AFU is off as shown in **Figure 5**.

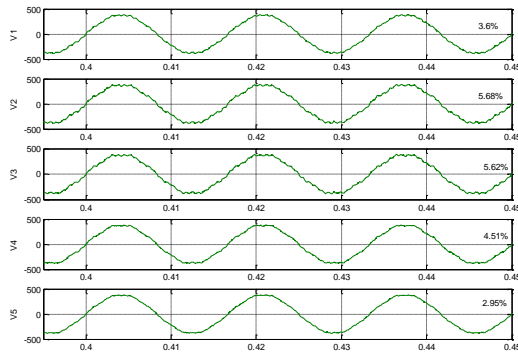

(a)

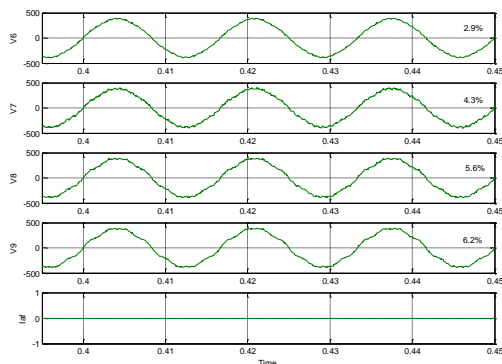

(b)

Fig. 5: Response of (a) bus voltages from 1 to 5 and (b) bus voltages from 6 to 9 and current when active filter unit is OFF

From **Figure 5** we observe that THD values of bus voltages at bus 3 is 5.62% and at bus 9 is 6.2%. The response of bus voltages

Line Parameters: $L = 3.1\%$ and $C = 13.7\%$.

Nonlinear Loads: NL_1 and NL_2 are constructed by three-phase diode-bridge rectifiers and consume real power 0.25pu and 0.25pu, respectively.

Linear Loads: Both linear loads are initially OFF. LL_1 and LL_2 are rated at 0.1pu (pf = 1) and 0.09pu (pf = 0.9) respectively.

Current Control: $k_p = 25$, $k_{i,5} = 100$, $k_{i,7} = 100$, and $\zeta = 0.01$.

distortion is enhanced when AFU is on as shown in **Figure 6**. The THD value of voltage at bus 9 is decreases from 6.2% to 4.85%, it having 3% of 5th harmonics and the 3% of 7th harmonics. **Figure 7** (blue curves) shows along line both VD_5 and VD_7 Curves are uniform.

The THD value of bus voltage 6 is less raised from 2.93% to 2.98% and this does not affect the performance of AFU, because the feeder having uniform voltage behind damping.

(a)

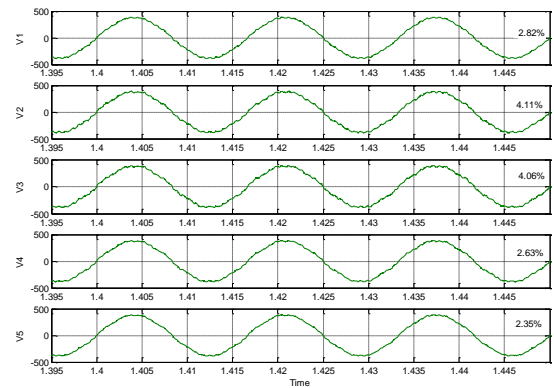

(b)

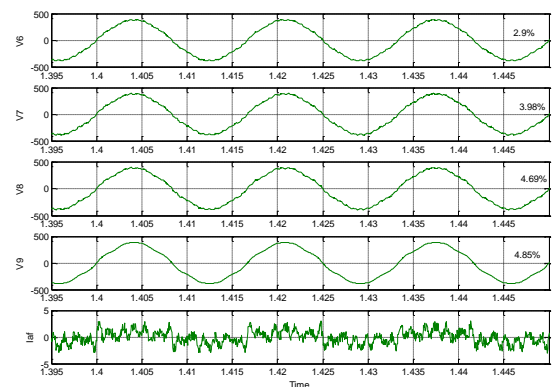

Fig. 6: Response of (a) Bus voltages from 1 to 5 and (b) Bus voltages from 6 to 9 and current when Active Filter Unit is ON

The comparison of THD values of bus voltages when AFU is off and when AFU is on using fuzzy logic controlled active filter by resonant current control is shown in **Figure 8**.

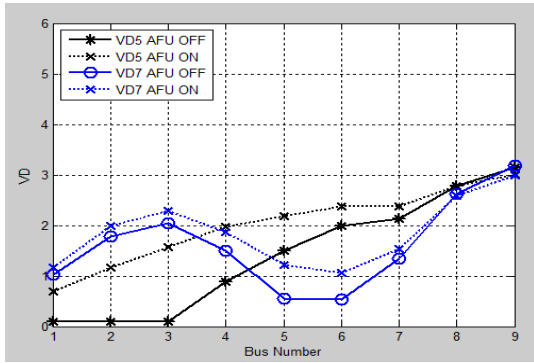

Fig. 7: VD5 and VD7 on all buses when AFU is operated and not operated

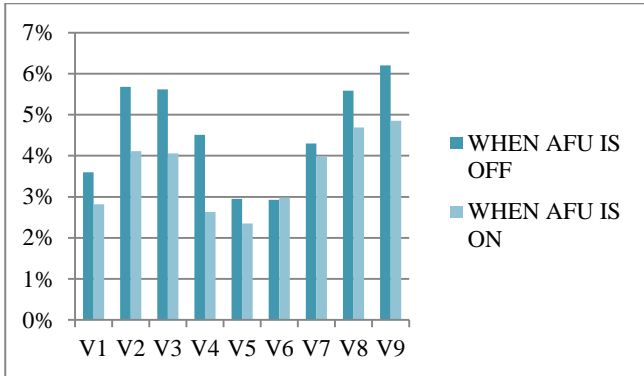

Fig. 8: THD values of bus voltages by fuzzy logic controlled active filter by resonant current controller

4.2 Response of Active Filter Under Transient

Response of active filter under Transient is described in this segment. Here, NL_1 and NL_2 are raised at time 1.5s and 2s then distortion of voltage is raised and then immediately LL_1 and LL_2 are turned on at time 2.5s and 3s as shown in Figure 9, it gives response of active filter unit is off for distortion of harmonic voltage.

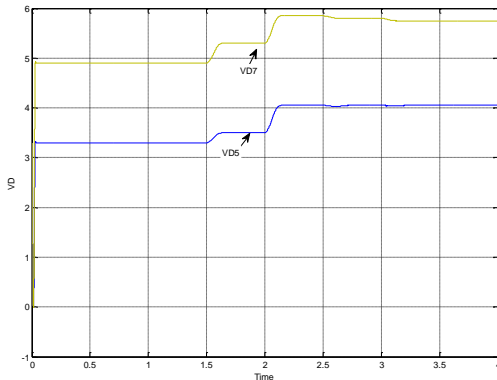

Fig. 9: Response of active filter unit is OFF for distortion of harmonic voltage

Here, decrease distortion of voltage by increase conductance of 5th harmonic i.e., G_5^* and 7th harmonic i.e., G_7^* in the tuning control for draw more harmonic current as shown in Figure 10 and linear loads are also decrease distortion at time 2.5s and 3s. Figure 11 gives response of active filter unit is ON for distortion of harmonic voltage be able to maintain as 3%.

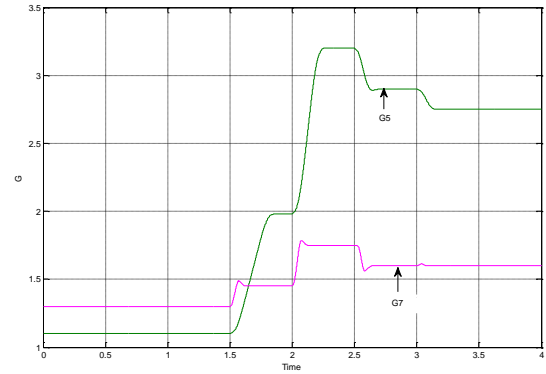

Fig. 10: Conductance commands of active filter

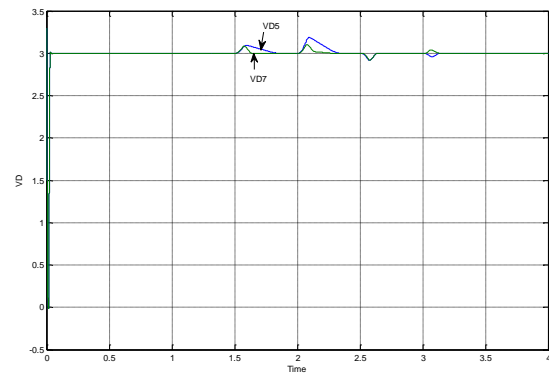

Fig. 11: Response of active filter unit is on for distortion of harmonic voltage

4.3 Response of Nonlinear Loads Connected At Various Places

The damping response of active filter unit is analyzed when nonlinear loads are connected at various places is evaluated in this segment.

Case 1:

When nonlinear loads are connected at buses 2 and 5 their corresponding distortion of voltages VD_5 and VD_7 are suppressed as shown in Figure 7.

Case 2:

When nonlinear loads are connected at buses 3 and 7 their corresponding distortion of voltages VD_5 and VD_7 are not obvious due to minor distortion as shown in Figure 12.

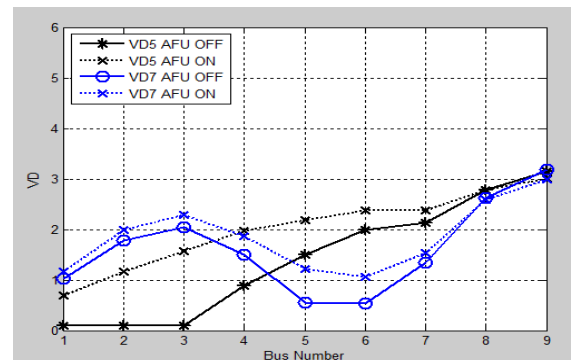

Fig. 12: When nonlinear loads are connected at bus3 and bus7 their damping response

Case 3:

When nonlinear loads are connected at buses 4 and 6 their corresponding distortion of voltage VD_5 is greater. So, reduce VD_5 by taking greater conductance G_5^* value as shown in **Figure 13**.

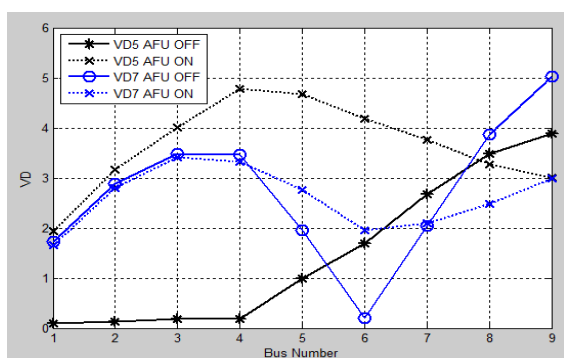

Fig. 13: When nonlinear loads are connected at bus4 and bus6 their damping response

If large G_5^* is assume when AFU can accidentally make 5th harmonic resonance as per whack-a-mole phenomenon and it can be solved by multiple active filters like in distributed active filter systems [9].

From above three cases we conclude that, when active filter unit is ON, VD_7 is suppressed and VD_5 is raised in center section of the line in all cases.

5. Conclusion

In this paper the mitigation of harmonic resonances using the Fuzzy logic Controller (FLC) based active filter by the resonant current control in the distribution system is proposed. For controlling active filter as nearly harmonic conductance, collections of different parallel band-pass filters are tuned for resonant current controller at harmonic frequencies. In order to maintain the performance of damping with respect to variations in load and system, the realization of separate tuning conductance for different harmonic frequencies. Harmonic resonance is induced at various locations in the line by using damping active filter due to controlling delay and nonlinear loads are presented at individual buses, it is scrutinized by harmonic distributed parameter model.

The proposed method simulation result shows the performance of harmonic resonance by fuzzy logic controller based active filter by resonant current controller is improved effectively.

References

- [1] W. K. Chang, W. M. Grady, and M. J. Samotyj, "Meeting IEEE-519 harmonic voltage and voltage distortion constraints with an active power line conditioner," *IEEE Trans. Power Del.*, 9, (1994), 1531–1537.
- [2] H. Akagi, "Control strategy and site selection of a shunt active filter for damping of harmonic propagation in power distribution system," *IEEE Trans. Power Del.*, 12, (1997), 354–363.
- [3] V. Corasaniti, M. Barbieri, P. Arnera, and M. Valla, "Reactive and harmonics compensation in a medium voltage distribution network with active filters," in *IEEE/ISIE International Symposium on Industrial Electronics*, (2007) 916–921.
- [4] J. H. R. Enslin and P. J. M. Heskes, "Harmonic interaction between a large number of distributed power inverters and the distribution network," *IEEE Trans. Power Electron.*, 19, (2004), 1586–1593.
- [5] IEEE Recommended practices and requirements for harmonic control in electrical power systems, *IEEE Std. (1993)* 519-1992.
- [6] H. Akagi, H. Fujita, and K. Wada, "A shunt active filter based on voltage detection for harmonic termination of a radial power distribution line," *IEEE Trans. Ind. Appl.*, (1999), 638–645.
- [7] K. Wada, H. Fujita, and H. Akagi, "Considerations of a shunt active filter based on voltage detection for installation on a long distribution feeder," *IEEE Trans. Ind. Appl.*, (2002), 1123–1130.

- [8] M. Saito, T. Takeshita, and N. Matsui, "Modeling and harmonic suppression for power distribution system," *IEEE Trans. Ind. Electron.*, 50, (2003), 1148–1158.
- [9] P.-T. Cheng and T.-L. Lee, "Distributed active filter systems (DAFSs): A new approach to power system harmonics," *IEEE Trans. Ind. Appl.*, vol. 42, (2006), 1301–1309.
- [10] W. K. Chang and W. M. Grady, "Minimizing harmonic voltage distortion with multiple current-constrained active power line conditioners," *IEEE Trans. Power Del.*, 12 (1997), 837–843.
- [11] I. Ziari and A. Jalilian, "A new approach for allocation and sizing of multiple active power-line conditioners," *IEEE Trans. Power Del.*, 25, (2010), 1026–1035.
- [12] D. M. Brod and D. W. Novotny, "Current control of vsi-pwm inverters," *IEEE Trans. Ind. Appl.*, 21, (1985), 562–570.
- [13] T.-L. Lee, J.-C. Li, and P.-T. Cheng, "Discrete frequency tuning active filter for power system harmonics," *IEEE Trans. Power Electron.*, 24, (2009), 1209–1217.
- [14] T.-L. Lee and S.-H. Hu, "Design of resonant current regulation for discrete frequency tuning active filter," in *Conf. Rec. IEEJ IP-EC Sapporo*, (2010).
- [15] D. N. Zmood, D. G. Holmes, and G. H. Bode, "Frequency-domain analysis of three-phase linear current regulators," *IEEE Trans. Ind. Appl.*, 37, (2001), 601–610.