

Multichannel Data Logger for Combat Vehicle

J. Antony Veera Puthira Raja^{1*}, J.A. Bharath Raj², M. Bharath³, P.C. Kishore Kumar⁴, V. Rajendran⁵

¹Research Scholar, Department of ECE, Vels Institute of Science, Technology & Advanced Studies.

²B.E Final Year, Department of ECE, Vels Institute of Science, Technology & Advanced Studies.

³B.E Final Year, Department of ECE, Vels Institute of Science, Technology & Advanced Studies.

⁴Assistant Professor, Department of ECE, Vels Institute of Science, Technology & Advanced Studies.

E-mail: kishore.se@velsuniv.ac.in

⁵HOD, Department of ECE, Vels Institute of Science, Technology & Advanced Studies.

Abstract

The multichannel data logger is the one of the prominent component in any instrumentation system, the control process to give a high resolution to store accurate data from the sensing elements which varies depends on the different applications. In this point of view there are many developed data loggers are customized and general purpose data logger are available in the market with typical sampling frequency of 100 KHZ. Although the general purpose data logger with many of the time is suitable for laboratory level purpose when it comes to the defense, very special testing procedure based manufacturing process, larger channel sensing methods with a well-designed and adapted to specific application based customized data logger always been the under development. Proposed data logger is enabled with 8 channels IoT (Internet of things).

Keywords: Data, logger, Multi-channel, sensors.

1. Introduction

A data logger is an electronic device used to analyze, collect and store the data. This helps in monitoring propose with absolute precision of environmental conditions. They are generally compact, portable, battery-powered and equipped with memory storage. It connects various sensors and converts physical phenomena's into electrical signal and then convert into binary bits. After conversion it can be easily analyzed by simulation software and stored in memory storage devices for post-process analysis. Data logger uses microcontroller to perform a task. Coded programs are dumped into a microcontroller to perform a desired task. "Embedded C" programs are widely used in data loggers to perform the required task. Coded programs are then dumped into microcontroller using emulator (or) simulation software. Sensors vary based on applications and depending on their needs and necessary. Data logger deals with some of the most commonly used sensors like air temperature, relative humidity, AC/DC current and voltage, differential pressure, time-of-use (lights, motors, etc.).EEPROM is mostly used for the storage of measured data. The data can also be stored in external storage for further uses or for easy transportation of the data. In many cases, the collected data or measured data are used to communicate with another location or a terminal by using wireless communication. Here lot mode of communication is mostly used for data transmission. Hence it becomes easier to fetch the data without going to the on-site.

2. Literature Survey

The basics of the data logger are explained clearly explained by Raghda Bakerey Khader Elssadig and Dr. Eltahir Mohammed

Hussien [1] by using a microcontroller. EEPROM for data storage and LCDs are used to display the readings. As for the methodology they used different sensors like temperature and ambient light density using a microcontroller. The final output of this paper is a monitoring and control of environmental parameters in a microcontroller-based data logger. A tutorial on monitoring the boiler temperature using RL-ARM Real-time operating system by G. H. Rajavignesh and B. Rajasekar [2]. This tutorial has presented the concept of a data acquisition system for boiler temperature using the real-timeoperating system. By using an ARM microcontroller and an LM35 temperature sensor they designed a system for industrial level temperature monitoring. For viewing accessing the stored data can by using an Electrically Erasable Programmable Read-Only Memory (EEPROM) and an LCD display. And on the softwareside, KEIL,µVISION, FLASH MAGIC is used. An AVR Microcontroller Based Temperature Control System with Real-Time Data Logger [3] is developed by Madukar S. Chavan, S. S. Sankpal3 and V.S.Suryawanshi for an Automatic Temperature Control system and data logger. The hardware part consists of an AVR controller, temperature sensor, and LCD module. And for software part, they used Visual Studio for displaying the data. As for the methodology, the temperature sensor and LCD display are connected to the AVR controller. The temperature sensor is reading the data and the LCD is to display the read data. AWi-Fi-based wireless Data logger is developed by Vikram Kamadal, Manjula N Harihar[4]. This paper gives the details of designing a wireless data logger using WI-FI. For the hardware implementation, they used Adafruit data logger, Sensors for sensing various physical parameters like temperature, pressure, and proximity, and Wi-Fi shield for wireless transmission of the data. The end result of this paper is a precise measuring of the physical parameter and wireless transmission system.

This paper by Chinenye D. Okwudibe and B.O Akinloye [5] explains the functions of design and simulation of temperature

data logger. The methodology consists of designing a simple circuit using an ADC microcontroller, LCD, Both RAM, and ROM. By using the ISIS professional (Animating), the designed circuit is simulated. A 2.5-d integrated data logger for measuring extreme accelerations by Jakobgakkestad, Et.al is a very compact and rugged 2.5-D data logger. It has the capability of measuring highest acceleration. The 2.5-D designing gives the advantage of reduced size, weight, and low power consumption. The final result is a graph like signal showing the acceleration from time to time.[6]

The development of a 32-channel wearable data logger by G.D. Gargiulo, Et.al is explained in this paper [7]. By using an NXP ARM processor and four ADCs the device is ultimately compact. The power consumption of the device is only 250mA. The designing of the system is done by using the keil software. Chenling Huang and Shantanu Chakrabarty designed a hybrid energy scavenging ICs which include asynchronous self-power sensor data logger {SDL}, which has the function of showing minimum downtime and continuous monitoring of data. By using SDL the need for voltage regulation, energy storage, ADCs, MCUs are eliminated [8]. This paper demonstrates the usage of a logical data logger with multimedia card memory by Robert Rieger, Yan-Ru Huang [9]. By using minimal configuration for designing the device reduces the cost, complexity and the size. Electrocardiogram signal is the final output from the device. The signal is sensed by the respective sensors. The logged data is stored in the multimedia card memory. Designing a secure data logger by Shlomo Engelberg, Et.al [10] gives an elaborate view in securing the measured data. This can be done in two ways, first is by cryptographic hash functions and the second is by using a public key encryption. By doing these steps, the measured data cannot be altered after it has been saved.

A USB-Enabled, FLASH-Disk Based on Data Logger by Shlomo Engelberg, Et.al [11]. They gave designing details on how to create a USB enabled data logger using USB, the measured data can be stored in a USB memory drive or a Flash disk. The main purpose of this paper is how to store the measured data in a sorting device for later use. This paper shows us the designing of a data logger for recording galvanic skin response. The measured data is then relayed to a computer for physiological analysis. Rajesh Luharuka, Robert X. Gao, and Sundar Krishnamurthy [12] presents a special algorithm for relative encoding to analyses the measured data. And it was a handheld device for easy use and reliability. Sakae Matsuzaki, Et.al [13] showed the development of data logger for CMP (Chemical Mechanical Polishing) by using a CMP processor and several I/O devices. The device takes the known and unknown data from the equipment and validates them as the unknown value changes. Values are measured by using various industrial level instruments. This paper gives the outline of how we can design a low-cost data logger for measuring environmental parameters. It is an open source data logger as of the program and the designing structure is openly available. The hardware consists of Arduino, Various sensors and a wireless transmission module for communication. And on the software side, the basic designing software was used [14]. An outlook on an environmental air pollution monitoring and alerting system based on sensor array and the renewable power source is given by Akanksha Shukla, Indra Thannaya [15]. This paper shows the integration of a device for monitoring environmental parameters such as SO₂, NO₂, CO₂, CO etc. For measuring various data, various sensors are used. And for the communication of data, a GSM module is used. In this paper the construction of a WSN monitoring system for indoor is explained elaborately. Here the WSN consists of sensors, Display, and controller. For the wireless transmission, ZigBee is used. By using WSN the performance of the data transmission is highly good. The LCD is used for displaying the measured data. The application of this paper is, that the range of transmitting the data is high [16].

Abhishek Singh, Anuj Kumar, Heisik Kim and Anshul Gaur proposed a fully functional smart sensing system for build

environment [17]. Their system was developed in compliance with the standard of IEEE 1451.2. It measures the air quality gases and environmental parameters. They used PIC18F4550 as the microcontroller. It is also a low cost, energy resistance, and portable. Cave Pearl Data Logger a low-cost data logging platform [18]. It is a long-term operational device in submerged environments. The power consumption of these devices was low i.e., AA batteries can long last for nearly a year. It is an easily built device. So this makes it a more flexibility in submerged environments. This device gives the solution for wide range environmental measurements. Anuj Kumar, Et.al designed and developed a fully functional 4-channel data logger for indoor environments [19]. It is developed by using a PIC 18F4458 microcontroller. EEPROM is used for storing the measured data. Parameters like temperature and humidity are measured. The measured data are seen with the help of graphical user interface. D.Bhattacharjee and R.Bera developed a smart detachable wireless sensing system for environmental parameters [20]. It was developed to the standard of IEEE 1451. This device is used to measure both barometric and alcohol. They used PIC 18LF2550 microcontroller and with various peripherals. And as of in communication side, they used 2.4 GHzXBEE.

3. Methodology

AVR 8-bit microcontroller, various sensors, and communication module are used to develop this system. Using Embedded C programming language the logging parameters (Temperature, Humidity, Pulse, etc.) are programmed. The data logger is connected to power supply to power up the device. The results for logging parameters are plotted in a graph using integrated development environment. The measured data will be sent to the remote center by using IoT mode of communication. And the data are stored in the memory storage (USB Pen drive) for later use. When the measured data exceeds the given threshold level (i.e., Maximum or minimum thresholds), the device will send an alert to the remote center and infrared camera detects object's Infrared energy, where the infrared energy is used to detect the heat coming from the objects. The detected infrared energy is gathered and processed as per the needs and requirements. The threshold values of TMP are assigned to each levels of values (TMP MIN 30= RED; TMP MAX 20= GREEN) to get the desired visual from the display. Flow chart showed in figure 2. It shows that Sensor data are converted into digital by corresponding data conversion method. Then the digitized data are processed with the help of microcontroller. Threshold limit are introduced after understanding the various threshold limit of sensors, controller and environmental condition. If the values of sensors lie between minimum and maximum threshold, then the sensor value store in memory, else current data will transmit promptly to remote centre.

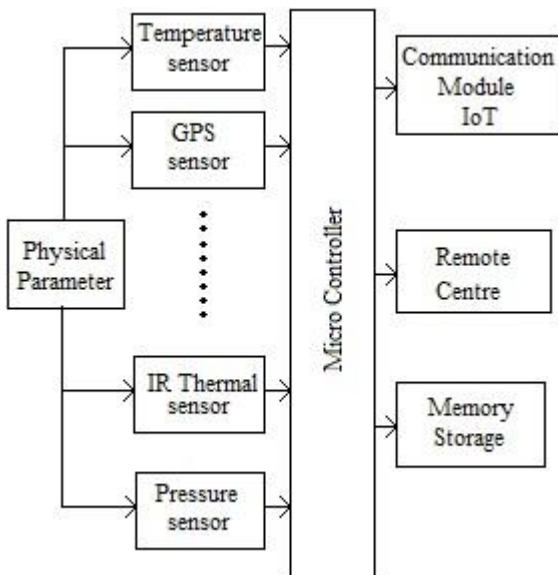

Fig. 1: Block diagram of proposed system

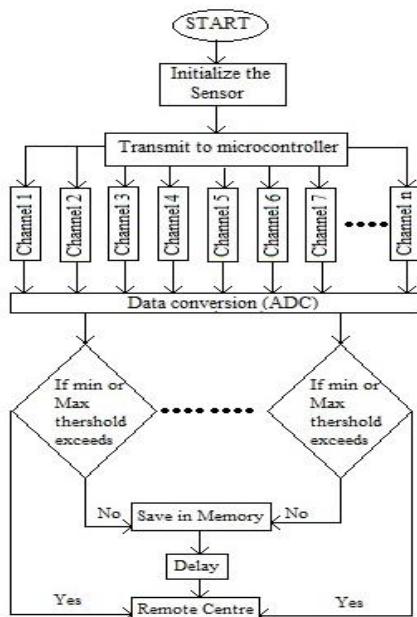

Fig. 2: Flowchart of proposed system

4. Hardware Implementation

Microcontroller

Here we are using an AVR 8-bit microcontroller. It is a low-power microchip which has 256kb ISP flash memory, 8KB SRAM, 4KB EEPROM, 86 general purpose I/O lines, 32 general purpose working registers, real-time counter, six flexible timer/counters with compare modes, PWM, 4 USARTs, byte-oriented 2-wire serial interface, 16-channel 10-bit A/D converter, and a JTAG interface for on-chip debugging. The device achieves a throughput of 16 MIPS at 16 MHz and operates within 4.5– 5.5 volt. Block diagram of microcontroller is shown in Figure 3.

Sensors

DS18B20 temperature sensor

The DS18B20 is a digital thermometer which 9-bit to 12-bit Celsius temperature measurements. The range of the temperature measurement is from -55°C to +125°C (-67°F to +257°F).It is powered by 5 volts.

Pulse Sensor

The pulse sensors work as the light from the led shines into the fingertip or other capillary tissue and the sensor reads the light that bounces back. Voltage supply for the sensor is +3V to +5V.

BMP180 Pressure Sensor

The BMP180 is a high precision digital pressure sensor. The supply voltage for this sensor is +1.8V to 3.6V. It can measure pressure from 300hPa to 1100hPa (i.e., +9000m ... -500m relating to sea level).

DHT11 Humidity Sensor

DHT11 Temperature & Humidity Sensor is a digital sensor which is used to measure the temperature and humidity in air. DHT11’s power supply is 3 - 5.5V DC. The measurement range is from 0°C to 50°C with ± 2°C accuracy. And the accuracy of humidity is ± 5% RH.

AMG8833 IR Thermal Camera

The AMG8833 is the next generation of 8x8 thermal IR sensors. The sensor only supports I2C. It will return an array of 64 Individual infrared temperature readings over I2C. The temperatures ranging from 0°C to 80°C (32°F to 176°F) with an accuracy of +- 2.5°C (4.5°F). The detection distance is up to 7 meters (23 feet). It works on the power supply of 3-5VDC.

Neo-6M GPS Module

Neo – 6M is a global positioning module, which has 50 channels on receiver type. This module is power with 5V. The configuration of the module is 0.25Hz to 1 kHzon-time pulse and Navigation update rate is up to 5Hz. The accuracy of the measurement is approx. 2.5m.

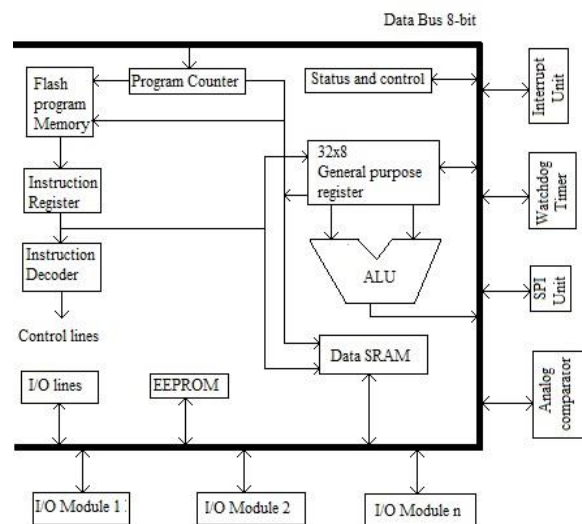

Fig. 3: Block diagram of microcontroller

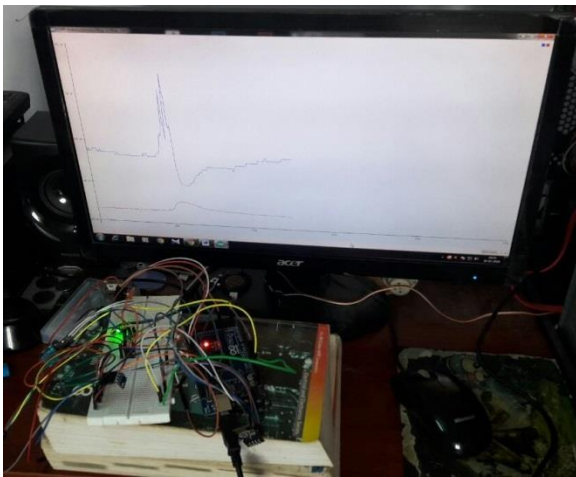

Fig. 4: Real time prototypes

5. Result and Analysis

Prototype of the entire system is shown in the Figure 4. This includes temperature, humidity, Pressure, Pulse, GPS, Thermal camera interface with display...etc. All the above sensors are connected to the microcontroller which has a built-in Analog to digital converter. Hence the analog data values are converted into digital data for processing. After processing, the data are transmitted over IoT to respective remote centre. Figure 5 shows the temperature and humidity in red and blue color respectively. Figure 6 shows the output for pressure sensor in terms of time (ns) and pressure(mb).Figure 7 shows the value of latitude and longitude form GPS sensor.

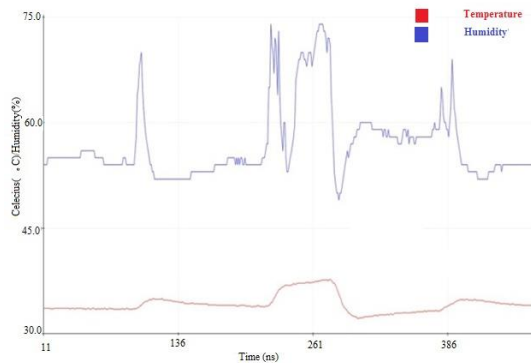

Fig. 5: DHT11 sensor results

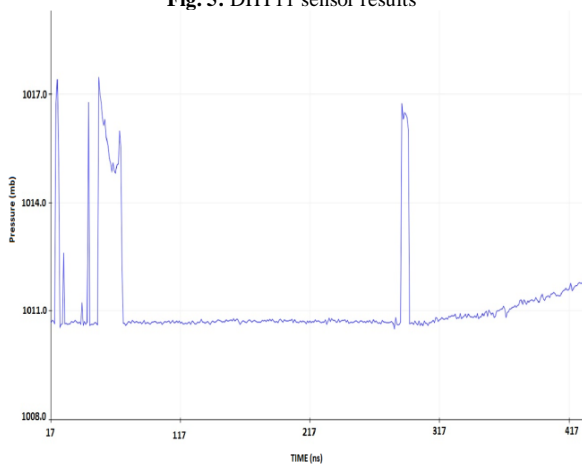

Fig. 6: Output of BMP180 pressure sensor

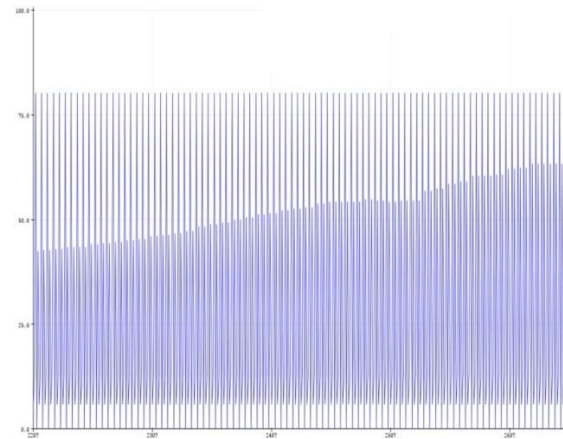

Fig. 7: Output of GPS

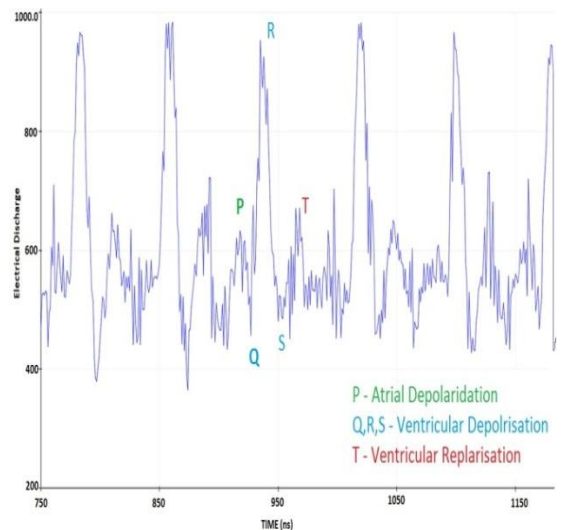

Fig. 8: Output of pulse sensor

Figure 8 shows the output for pulse sensor with various factors like atrial depolarization, ventricular depolarization and repolarization. Which is represent by P,Q,R,S and T in figure 8. Thermal camera are used in this data logger to find the intrusion detection in LOC region in boundary of the nation. It shows the thermal image of any object and things which emits heat. By interfacing this intrusion detection is possible with our proposed data logger system. This prototype is shown in figure 9.

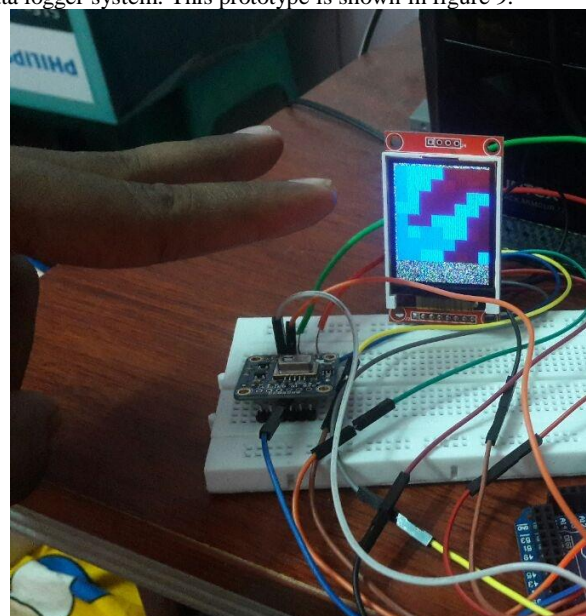

Fig. 9: Output of IR thermal camera

6. Conclusion

In this paper, it is infer that the proposed multichannel data logger consist of various parameter like temperature, pulse, pressure ,Latitude , Longitude ,Thermal ,Humidity and Inside parameter of combat vehicle. All the acquired data from combat vehicle were transmit to the remote station through Internet of Things. In future, the proposed work can be enhancing by integrating certain feature like military grade components, direct satellite interface, shock, water and fire proof.

International Journal on Smart Sensing and Intelligent Systems
Vol.7, No.3, (2014).

References

- [1] Elssadig RBK & Hussien EM, "Microcontroller Based Data Logger", *International Journal of Engineering, Applied and Management Sciences Paradigms*, Vol.42, No.01, (2016).
- [2] Rajavignesh GH & Rajasekar B, "Data Logging of Boiler Temperature Using Real Time Operating System", *Asian Research Publishing Network (ARPN)*, Vol.11, No.9, (2016).
- [3] Chavan MS, Sankpal SS & Suryawanshi VS, "AVR Microcontroller Based Temperature Control System with Real-Time Data Logger", *International Journal of Advance Research in Computer Science and Management Studies*, Vol.2, No.11, (2014).
- [4] Kamadal V & Harihar MN, "WI-FI Based Wireless Datalogger", *International Journal of Science and Research*, Vol.4, No.8, (2015).
- [5] Okwudibe CD & Akinloye BO, "Design And Simulation Of Temperature Data Logger", *American Journal of Engineering Research (AJER)*, Vol.6, No.12, (2017).
- [6] Gakkestad J , Sollund T, Dalsjø P, Tveit B, VisserTaklo MM, Wright DN, Helland S, Kristiansen H & Johnsen C, "A 2.5-D Integrated Data Logger for Measuring Extreme Accelerations" , *IEEE Transactions on Components, Packaging and Manufacturing Technology*, Vol.7, No.12, (2017).
- [7] Gargiulo GD, Bifulco P, Cesarelli M, McEwan A & Wabnitz A, "Open platform, 32-channel, portable,data-logger with 32 PGA control lines for wearable medical device development", *Electronics Letters*, Vol.50, No.16, (2014), pp.1127–1129.
- [8] Huang C & Chakrabarty S, "An Asynchronous Analog Self-Powered CMOS Sensor-Data-Logger With a 13.56 MHz RF Programming Interface", *IEEE Journal of Solid-State Circuits*, Vol.47, No.2, (2012).
- [9] Rieger R & Huang YR, "A Custom-Design Data Logger Core for Physiological Signal Recording", *IEEE Transactions on Instrumentation and Measurement*, Vol.60, No.2, (2011).
- [10] Engelberg S, Cohen B & Yucht E, "Designing a Secure Data-Logger", *IEEE Instrumentation & Measurement Magazine*, (2009).
- [11] Engelberg S, Kaminsky T & Horesh M, "A USB-Enabled, FLASH-Disk-Based Data Logger", *IEEE Instrumentation & Measurement Magazine*, (2007).
- [12] Luharuka R, Gao RX & Krishnamurty S, "Design and Realization of a Portable Data Logger for Physiological Sensing", *IEEE Transactions on Instrumentation and Measurement*, Vol.52, No.4, (2003).
- [13] Matsuzaki S, Tanzawa A, Igarashi T, Suzuki T & Tokushige K, "Development of Data Logging System for Chemical Mechanical Polishing and Its Application for Process Control", *IEEE Transactions on Semiconductor Manufacturing*, Vol.15, No.4, (2002).
- [14] Baker Ed, "Open source data logger for low-cost environmental monitoring", *Biodiversity Data Journal*, (2014).
- [15] Shukla A & Thannaya I, "An Environmental Air Pollution Monitoring and Alerting System Based on Sensor Array and Renewable Power Source", *International Conference on Computing, Communication and Energy Systems*, (2016).
- [16] Mon YJ, Lin CM & Rudas IJ, "Wireless Sensor Network (WSN) Control for Indoor Temperature Monitoring", *Acta Polytechnica Hungarica*, Vol.9, No.6, (2012).
- [17] Singh A, Kumar A, Kim H & Gaur A, "Smart Sensing System for Built Environment", *IJSER*, Vol.3, No.10, (2012).
- [18] Beddows PA & Mallon EK, "Cave Pearl Data Logger: A Flexible Arduino-Based Logging Platform for Long-Term Monitoring in Harsh Environments", *Sensors*, Vol.18, No.2,(2018).
- [19] Kumar A, Singh IP & Sud SK, "Design and Development of Multi-Channel Data Logger for Built Environment", *IMECS*, (2010).
- [20] Bhattacharjee D & Bera R, "Development of Smart Detachable Wireless Sensing System for Environmental Monitoring",