



Core Loss Measurement of Somaloy 700 Material Under Round Loci of Magnetic Flux Density

Ashraf Rohanim Asari^{1*}, Youguang Guo², Jianguo Zhu³

¹Instrumentation and Control Engineering Section, Universiti Kuala Lumpur (MITEC), Malaysia
^{1,2,3}Faculty of Engineering and Information Technology, University of Technology, Sydney, Australia
*Corresponding author E-mail: ashraf@unikl.edu.my

Abstract

The magnetic properties of SOMALOY 700 material are aggressively studied by some researchers in predicting the production of total core loss during the magnetization process of that particular material. Core loss is resulted due to the alternating and rotating magnetic fields in a core material. The magnetic properties of SOMALOY 700 material is studied in this paper since it offers the low core loss during the operation. 2-D measurement were conducted by controlling the fluxes to be circular with the help of LabVIEW while the core loss calculations were calculated by MathCAD. The performance of SOMALOY 700 material at different frequencies were compared. The finding indicates that the magnetization at 1000 Hz contributes higher core loss compared to the magnetization at 500 Hz and 50 Hz. The details of SOMALOY 700 material provide good information to practitioners in designing electrical machine at different variation of frequencies.

Keywords: Core Loss; SOMALOY 700; Round Loci

1. Introduction

The study of rotating core loss gives big significance to the rotating electrical machines since in real situation, the magnetic flux densities are rotated during the operation of this machine. Thus, the magnetic core loss under rotating magnetic field excitation is required to be examined before being applied in designing and performing simulation of the electrical devices.

There is very important to have a good understanding of core loss in electrical machine. By identifying the actual core loss, the operating cost can be reduced after the determination of electrical machine efficiency. The heating of the machines also can be evaluated and the power output is able to be determined without excessive degradation of the insulation.

The flux densities are rotated in arbitrary shapes such as in round and ellipse to predict the core loss to be similar with the existing core loss in actual rotating electrical machines. The presence of B , makes the magnetic domain rotated and the wall of domain is started to move from the origin position. Hence, it will increase the total core loss of the magnetic material due to the additional of eddy current loss which is affected by that domain wall motion.

2. Literature Review

2.1. 3-D Magnetic Property Testing System (3-D Tester)

Magnetization under alternating and rotating B on magnetic material will make the magnetic domain to be rotated. Due to that, the study of magnetic property of SOMALOY 700 under 3-D vector flux excitation is needed (1).

In 2001, the 3-D tester was magnificently invented by Zhu *et al.* in order to magnetize the sample of soft magnetic materials (2), (3). This whole system comprises a 3-D yoke to guide the magnetic fluxes production in three axes, which is wound by three groups of excitation coils, a data acquisition system, three pairs of excitation coil that is used to produce B along x , y and z axes in various shapes such as alternating, rotating in 2-D plane and rotating in 3-D space with the loci of B , thus various B loci like circular and elliptical of rotating B can be gained by controlling the three components of B vectors (4), (5),(6). To ensure the shapes of B to be similar as controlled by user, a feedback control system that consists of control unit and high power amplifier is attached to the 3-D tester (3), (7).

Figure 1 (a) describes that LabView is used to generate the voltage waveforms of B along x , y and z -axes before being transferred to a three-channel linear power amplifier. Then, the amplified voltage waveforms are fed to the excitation winding coils through digital to analog converter. The x , y and z components of voltage signals which are induced by B and H sensing coils can be read and detected by the MathCad by collecting these signals through analog to digital converter. The signals V_{Bx} , V_{By} , V_{Bz} , V_{Hx} , V_{Hy} and V_{Hz} are used to obtain the correlation of B and H . By knowing the correlation of B and H , the magnetic properties of the sample can be determined by calculating the core loss of the sample during the magnetization. The signals of B are also used for feedback control of the waveforms (1). Figure 1 (b) is the structure of the 3-D tester with cubic sample and search coils are located inside the tester (2).

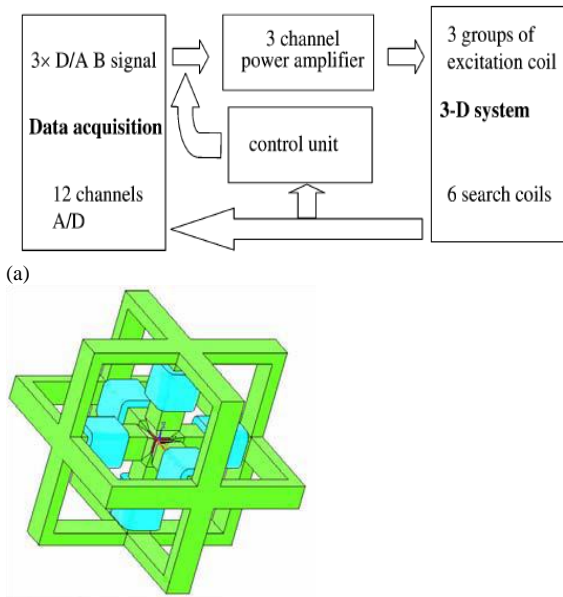

Fig. 1(a): 3-D tester (8) (b) Framework of 3-D tester (2).

Three components of magnetic field vector can be detected by three search or sensing coils that are wound around the cubic sample while magnetic field strength H, can be measured by the calibrated H search coils which is located on the six surfaces of the sample as illustrated in figure 2 (2).

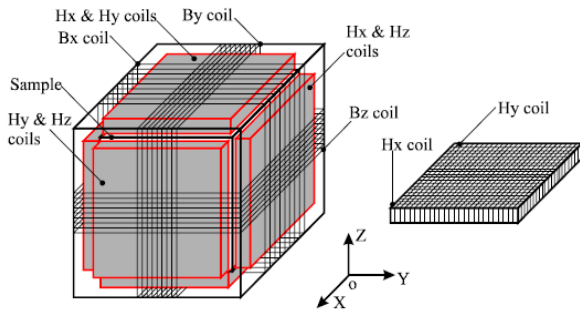

Fig. 2: A magnetic sample with its B and H sensing coils covered on the surface (2).

From the figure above, it illustrates that there are two sensing coils, H_x and H_y and one B sensing coil, B_z on each surface of the magnetic sample and it leads to the twelve sensing coils of H and six sensing coils of B (2), (9). As stated by Faraday's Law, the EMFs are induced when there is changes of magnetic flux which is occurred inside the 3-D magnetic property testing system. The induced EMFs have been considered in determining B and H that are produced on each axis (2). From both formulations, the value of coil coefficients K_H or K_B , would be determined to calculate B at the sample surface (2). Figure 3 exhibits the calibration of sensing coils which is conducted in a long solenoid to obtain the coil coefficients of both K_H and K_B .

2.2. Calibration of Sensing Coils

Calibration of sensing coil was deliberated by Guo *et al.* in 2006 by considering the equations (1-4). In order to remove the system errors before being engaged to define the magnetic field components during the magnetization process inside the 3-D tester (10).

$$B_i = \frac{1}{K_{B_i}} \int V_{B_i} dt \tag{1}$$

$$K_{B_i} = N_{B_i} A_{sp} \tag{2}$$

$$H_i = \frac{1}{\mu_0 K_{H_i}} \int V_{H_i} dt \tag{3}$$

$$K_{H_i} = \frac{V_H}{\sqrt{2} \pi f \mu_0 H_m} \tag{4}$$

($i=x, y, z$)

Where V is the induced EMF, $\mu_0 H_m$ is the maximum value of B in the center of the solenoid, f is the excitation frequency, and A_{sp} is the cross-sectional area of the sample.

During the calibration, excitation current which is supplied by AC power supply would enter the solenoid coils and the changing of current leads to the generation of B inside and outside the solenoid. The uniform and maximum magnetic B_m , flux density has been recorded at the center of the long solenoid and it will be read by the gauss meter. The H sensing coil inside the long solenoid is perpendicular to B.

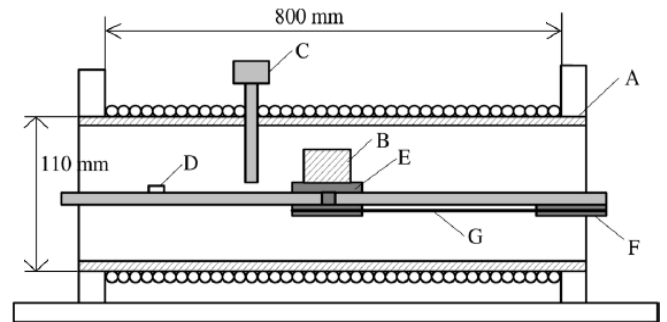

Solenoid: $N=939$ (turns), and $H/l=1162.8$ (1/m)

Fig. 3: Calibration of H sensing coils in the long solenoid (8).

Li *et al.* improved the original structure of 3-D magnetic properties testing system in 2009 by revising the size of the H coil which is approximately equal to the side of the cubic sample. The size of H sensing coil contributed to the non-uniform magnetic field at the measured area due to the demagnetization factor (4). To ensure the accuracy of the measurement, H sensing coil has been modified to be smaller area by forming it $(8.5 \times 6) \text{ mm}^2$. Two layers of coils with a small cross angle are able to induce signals with same magnitude but in different direction (9). The improvement also has been done on sensing box which is used to combine all six sensing coils of B and six sensing coils of H as illustrated in figure 4. The very thin and small circle of 60 turns B coil is embedded in the center of the epoxy resin frame with 200 turns of H coil cover the circular by winding around a 0.5 mm thick epoxy resin (4). In this study, the measurement error has been reduced by using the 0.05 mm enameled copper wire for both B and H sensing coils. Besides that, the wires have been twisted at terminal and adoption of cross bedded winding structure are considered to eliminate the unwanted stray field that leads to induce the additional (11). Hence, the condition of twisted terminal of each coil can solve the problem of induction error as stated by Zhong *et. al* in 2006 (12). To connect coils on the opposite surface sides in series, six combination sets of B and H coils are attached on each cubic sample surface (4).

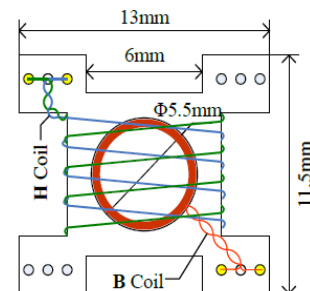

Fig. 4: The improvement of H and B sensing coils (4).

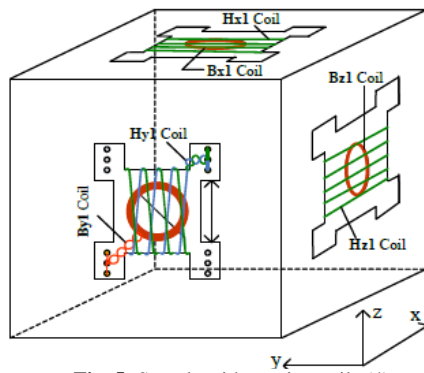

Fig. 5: Sample with sensing coils (4).

The measurement are accurate and precise with this new structure since there is a closely attached between H coils and sample. This condition is really demanded in getting the uniform B near the central area of the sample. The calibration of the upgraded B and H sensing coils are also have been performed in a long solenoid due to the high and uniform B which is able to be obtained at the center of the solenoid (13).

3. Methodology/Materials

In order to produce the round shape of B, two sinusoidal waves of B are controlled to be in the same magnitude with 90° of phase angle. It will be resulting the round B loci along a plane of 2 axes such as xoy , yoz and zox .

Ideally, the magnetic flux density in the stator can be electrically rotated and it will be attracted or repelled by another magnetic flux density in rotor. Due to this concept, the rotating magnetic field is trying to be generated in this study to obtain the accurate reading of core loss which is experienced by the stator and rotor parts during their operation. Arbitrarily, the magnitude and direction of magnetic flux densities are circularly controlled and the plotted B loci are expressed in a xoy , yoz or zox - plane.

To produce round B that lies in xoy plane, both magnitudes of B_x and B_y should be in the same value with one of them is leading by 90° at certain desired frequencies. DAQ devices from National Instrumentation (NI) has been used as an interface to generate and control B waveforms by using LabVIEW software.

In details, the magnitude and phase angle between B_x and B_y are controlled in front panel of LabVIEW which is able to produce AC voltage waveforms in x and y - directions. Then, the waveforms are being amplified by using power amplifier (model: AM3002) which can amplify 63.5 times or 36 dB before generating B by the existence of excitation winding coil in the 3-D tester (14).

4. Results and Findings

The series magnetic properties of the SOMALOY 700 material is measured from low to high frequency. At 50 Hz, the excitation of circular magnetic fields is controlled to be increased up to 1.4 T. Due to high vibration and high heat generation at high frequency, the magnetic flux excitation is circularly controlled up to 0.36 T for 500 Hz and 0.08 T for 1000 Hz. All the recorded B and corresponding H loci are shown in figure 6 (a), (b) and (c) respectively where the left side represents the B loci and the other side gives the information of H loci. The figures explain that both B and H loci lie in the same magnetization plane. However, the H loci are started with elliptical shape and become distorted in the end of the measurement. It is caused by the movement of rotating domain during the magnetization which will portray the anisotropy property when there is involvement of high magnetic field in different direction (11)(15).

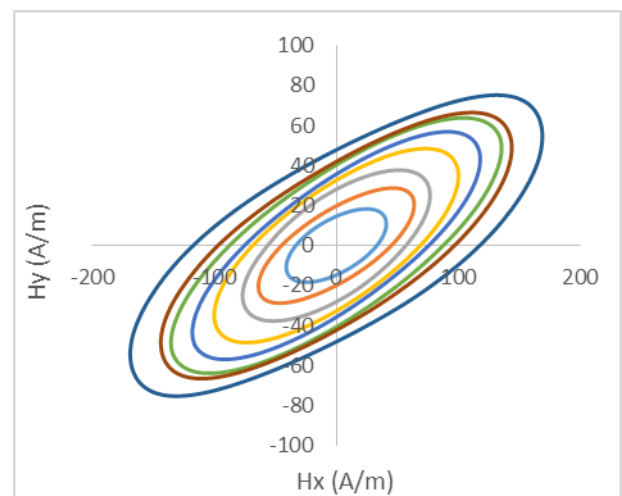
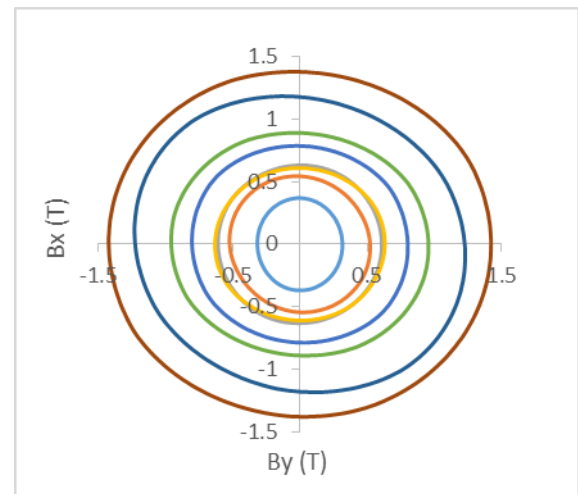

(a)

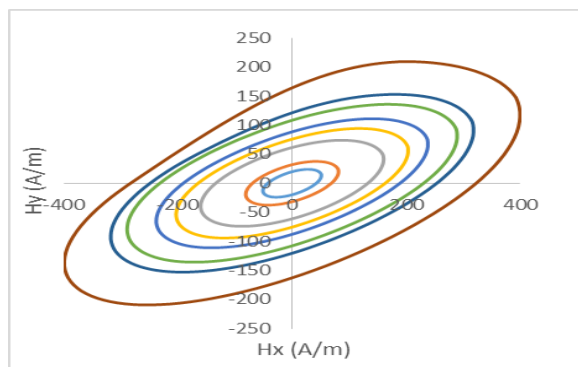
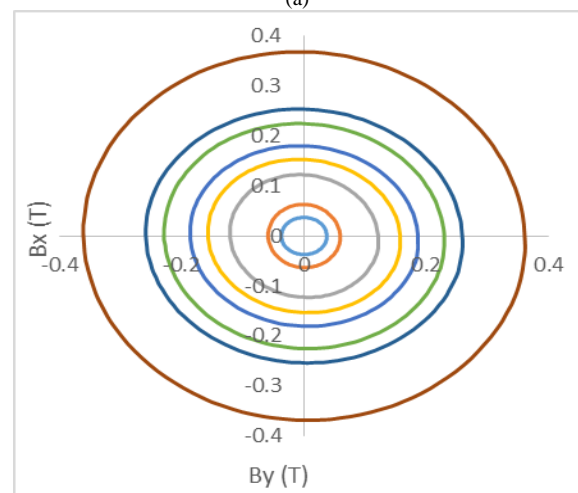

(b)

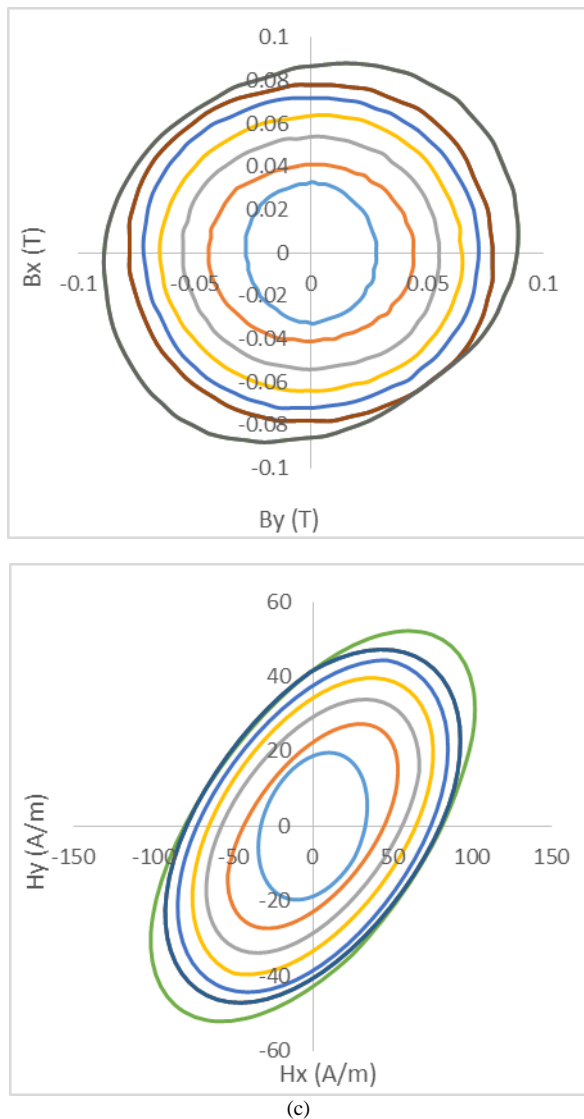

Fig. 6: Circular B loci and their corresponding H loci in 2-D plane at three different operating frequencies: (a) 50 Hz (b) 500 Hz and (c) 1000 Hz.

At 1000 Hz of magnetization, it shows that the shape of circular B loci is quite shaky due to coupling between core poles. This also leads to the noise production but it does not contribute to the core losses (16). Figure 7. (a), (b) and (c) describe the total core loss of 2-D measurement for SOMALOY 700 material at 50 Hz, 500 Hz and 1000 Hz respectively. It is total summation of individual core loss form x and y magnetic field excitations. This figure also can be known as loss curve that explains the core loss versus magnetic flux density graph. From this figure, it obviously shows the total core loss is proportional to the squared of B. The changes of the magnetic domain during the sample magnetization will make the domain wall to be moved. Thus, in the presence of high magnetic flux excitation, the possibility of domain walls to be snagged to crystal structure of material is high and this situation contributes to the high core loss.

At 1.4 T of B, the recorded total core loss at 50 Hz is around 4 Watt/ kg which is lower than total core loss at 500 Hz and 1000 Hz. However, the total core loss recorded at 500 Hz is 342.6 Watt/ kg and the total core loss at 1000 Hz is 1343.5 Watt/ kg. The limitation in obtaining the core loss at high magnetic flux excitation is solved by considering the trendline in plotting the core loss curves. When comparing all graphs in figure 7, it obviously shows that the core loss is increased with the operating frequency. This is caused by the magnetic material vibration that leads to the extra heat dissipation upon core loss measurement. Other than magnetic core loss, there are another effect that can contributed in high frequen-

cy of magnetization such as thermal effects on hysteresis, skin effects in winding coils and cores, and the effect of leakage inductance and stray capacitance (17).

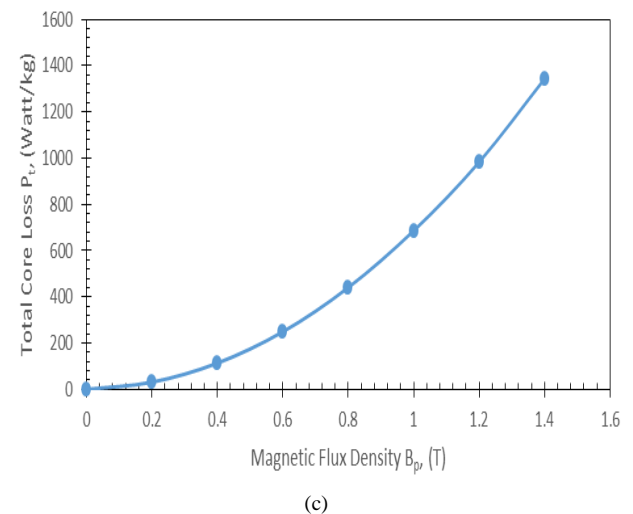
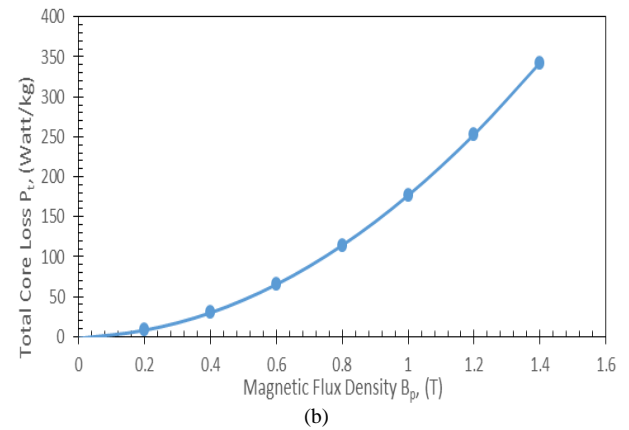
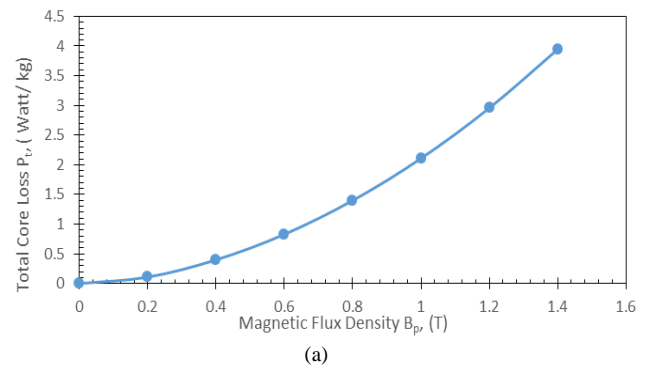

Fig. 7: Loss curve of SOMALOY 700 material in xoy - plane when flux densities are controlled to in round shape at (a) 50 Hz (b) 500 Hz and (c) 1000 Hz

5. Conclusion

The measurements that involved the circular magnetic fluxes have been conducted by using the 3-D tester. The results of experiment at certain range of frequency such as B loci, corresponding H loci and loss curve are described. The loci of both B_x and B_y are controlled to be circular in order to resemble the actual magnetic flux excitation in rotating electrical machines. It can be concluded that the core loss is higher at 1000 Hz compared to 500 Hz and 50 Hz due to the rotating domain particle during the magnetization process. In the future, the magnetic properties of this material will be measured up to 3-D of magnetization phenomenon.

References

- [1] J. J. Zhong and J. G. Zhu, "Electromagnetic design of a 3D tester for magnetic properties of soft magnetic materials," in *ICEMS 2001 - Proceedings of the 5th International Conference on Electrical Machines and Systems*, 2001.
- [2] J. G. Zhu, "MEASUREMENT OF CORE LOSSES WITH 3D MAGNETIC FLUXES," no. 5, p. 4405, 2003.
- [3] Z. W. Lin, H. W. Lu, J. G. Zhu, J. J. Zhong, X. L. Wang, and S. Y. Ding, "Vector characterization of soft magnetic materials," *J. Appl. Phys.*, vol. 97, no. 10, 2005.
- [4] Y. Li *et al.*, "Improved measurement of three-dimensional magnetic properties of SMC material," in *2009 International Conference on Applied Superconductivity and Electromagnetic Devices, ASEMD 2009*, 2009.
- [5] M. Tadashi Sasaki and S. T. and Y. S. Imamura, "Measurement of rotational power losses in silicon-iron sheets using wattmeter method," vol. M, no. 5, pp. 1918–1920, 1985.
- [6] Y. G. Guo, J. G. Zhu, Z. W. Lin, and J. J. Zhong, "3D vector magnetic properties of soft magnetic composite material," *J. Magn. Magn. Mater.*, vol. 302, no. 2, pp. 511–516, 2006.
- [7] Z. W. Lin, J. G. Zhu, G. Guo, J. J. Zhong, and H. W. Lu, "B and H sensors for 3-D magnetic property testing," *Int. J. Appl. Electromagn. Mech. Netherlands*, vol. 25, no. 1–4, pp. 517–520, 2007.
- [8] Y. Guo, J. Zhu, Z. Lin, J. Zhong, H. Lu, and S. Wang, "Calibration of sensing coils of a three-dimensional magnetic property tester," *IEEE Trans. Magn.*, 2006.
- [9] Y. Guo, J. G. Zhu, Z. W. Lin, J. J. Zhong, H. Y. Lu, and S. Wang, "Determination of 3D magnetic reluctivity tensor of soft magnetic composite material," *J. Magn. Magn. Mater.*, vol. 312, no. 2, pp. 458–463, 2007.
- [10] Y. Li, Q. Yang, Y. Liu, Z. Zhao, C. Zhang, and D. Li, "A Novel Combined B–H Sensing Coil in Three-Dimensional Magnetic Properties Testing System," *IEEE Trans. Appl. Supercond.*, vol. 24, no. 3, 2014.
- [11] Y. Li, Q. Yang, J. Zhu, and Y. Guo, "Magnetic properties measurement of soft magnetic composite materials over wide range of excitation frequency," *IEEE Trans. Ind. Appl.*, 2012.
- [12] J. J. Zhong, Y. G. Guo, J. G. Zhu, and Z. W. Lin, "Characteristics of soft magnetic composite material under rotating magnetic fluxes," *J. Magn. Magn. Mater.*, vol. 299, pp. 29–34, 2006.
- [13] M. Enokizono, G. Shirakawa, T. Suzuki, and J. Sievert, "Two-Dimensional Magnetic Properties of Silicon-Steel Sheet," no. 1, pp. 937–946, 1991.
- [14] A. Monitor, "Australian Monitor."
- [15] V. Basso and G. Bertotti, "Hysteresis in soft magnetic materials," *J. Magn. Magn. Mater.*, vol. 215, pp. 1–5, 2000.
- [16] Y. J. Li, Q. X. Yang, Y. H. Wang, J. G. Zhu, and Z. W. Lin, "Rotational core loss features of soft magnetic composite materials under excitation frequencies from 5 Hz to 1000 Hz," in *2013 IEEE International Conference on Applied Superconductivity and Electromagnetic Devices, ASEMD 2013*, 2013.
- [17] H. Lu, Y. Guo, J. Zhu, J. Zhong, and J. Jin, "Soft Magnetic Materials for High Frequency High Power Density Transformers in Power Electronic Systems," *Acad. Mag.*, vol. 11, no. 1, 2007.