

Design and Analysis of Modified Diode Rectifier Circuit Suitable for Piezoelectric Energy Harvester for Biomedical Applications

S S. Dhayabarasivam^{1*}, K.Jayanthi², Gouthame Pragatheeswaran³

¹Department of Electronics and Communication Engineering, Pondicherry Engineering College, Puducherry state, 605014, India;

²Department of Electronics and Communication Engineering, Pondicherry Engineering College, Puducherry state, 605014, India;

³Department of Electronics and Communication Engineering, Coimbatore Institute of Technology, Coimbatore, India;

*Corresponding author E-mail: engineersshivam@rediffmail.com

Abstract

Nowadays renewable energy sources play a significant role in the energy harvesting. For the past decade various energy harvesting methods have been discussed by researchers for capturing the energy from different sources. From the survey, one of the most prominent methods is the use of piezoelectric transducers for harvesting the energy. It is known that piezoelectric energy harvesting is the easiest method of energy harvesting from the various sources available such as human walking, dancing etc. Therefore this method can be implemented in system for wide variety of applications. The piezoelectric transducer AC output is of very low voltage and power and hence insufficient to drive any electrical application. Most of the small scale electrical application generally runs on the DC voltage, therefore the AC voltage obtained from the piezo transducer vibration is rectified using rectifiers to generate DC voltage. Thus in this paper, a modified rectifier AC/DC converter with the combination of an inductor is placed in the rectifier, which enhances the voltage and power from the rectifier output. In order to enhance the voltage rating, a DC/DC converter has been added at the end of a rectifier circuit. From the simulation results the proposed circuit modified rectifier has improved the output voltage as well as output current by 10.19 volts and 0.1019 amps respectively for input voltage of 5V. When compared with conventional rectifier circuit.

Keywords: Energy harvesting; Rectifier; Converter; Piezoelectric

1. Introduction

Generally abundant quantity of ambient energy such as heat flows, visible light, physical motion are existing in and around us, which can be transformed into a valuable amount of electrical energy. Out of these energies, the most prevalent generated electrical energy is through the process of mechanical to electrical energy in the form of vibration which was described by Beeby et al. [1]. Usually, vibration energy harvesting uses transducers to harvest small-scale ambient energy. As we know that in electromagnetic converters, voltage is generated by voltage by moving a coil relative to a fixed magnetic field [2]. In the electrostatic converters, energy is generated by changing the distance between the conducting plates placed due to vibrations in the variable capacitor. The piezoelectric converter consists of mechanical to electrical and electrical to mechanical converters. In the mechanical to electrical energy conversion the energy harvesting circuits are usually applied [3]. The generated output power ranges from hundred micro-Watts to several milli-Watts. When applied in the real time application, the acceleration level of ambient vibration is relatively low, hence it is not compatible with conventional rectifying circuit. It is defined that energy harvesting is a process of capturing small amounts of energy being lost in the form of heat, light, sound, vibration or movement. These ambient vibrations are transformed in to electrical energy using piezoelectric materials. This can be stored and used to power other devices. Several research papers have discussed harvesting of piezoelectric energy using rectifier circuits with larger input voltage [4, 5, 6]. This paper focuses on

proposing a piezoelectric energy harvester that can tap human potential into alternating current (AC) due to the occurrence of distortion in the piezoelectric element using full bridge rectifier [7], [8]. But, the piezoelectric energy circuit using only one rectifier as an interface circuit cannot obtain the electrical energy efficiently because of "energy return phenomenon" where the electrical energy returns to the vibration energy in each cycle [9]. It is known that piezoelectric energy circuit designed using a half wave rectifier cannot be connected to a switched-inductor, hence the switched-inductor is usually used in a piezoelectric energy circuit with full-wave rectifier [10], [11]. In this work, a modified rectifier based energy harvesting circuit has been demonstrated to perform better harvesting than the classic rectifier based piezoelectric energy harvesting circuit. The MATLAB-Simulink software is used of the conventional rectifier and proposed modified full wave rectifier for comparative analysis.

2. Piezoelectric Energy Harvester

A rare characteristic of particular crystalline minerals was discovered by Jacques and Pierre Curie in 1880, i.e., when crystalline minerals were subjected to a mechanical force, the crystals became electrically polarized. Most of the piezo type materials such as lead zirconate titanate; piezo-ceramic etc. is used in the energy harvesting applications. When an input vibration is applied onto a piezoelectric material, mechanical strain develops across it, which in turn results in the form of electrical charge [12]. From the analysis for power generation, the commonly used piezoelectric material is Lead-Zirconate-Titanate (PZT). The Fig.1 repre-

sents an equivalent circuit of the piezoelectric harvester, where a mechanical spring mass system is being coupled to an electrical domain. Here, L_M represents the mechanical mass, C_M the mechanical stiffness and R_M takes into account the mechanical losses. A transformer couples the mechanical domain to the electrical domain to generate current from strain.

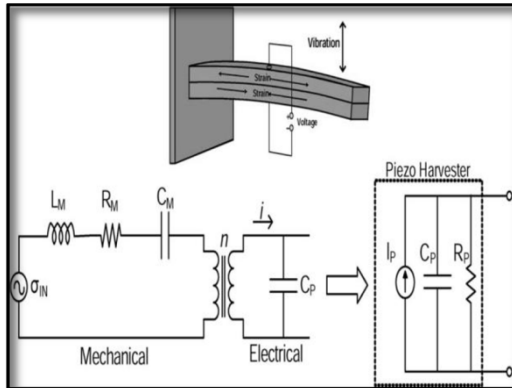

Fig. 1: Equivalent circuit of piezoelectric harvester [12].

On the electrical side of the Fig. 1, the plate capacitance of piezoelectric material is represented as C_p . The entire circuit can thus be transformed into the electrical domain. In this electric domain, the piezoelectric element excites due to sinusoidal vibrations on the piezoelectric element is generally modeled as a sinusoidal current source connected in parallel with a capacitance C_p and resistance R_p . The most challenging part with this type of a power generator circuit relates to process of design and construction. This circuit is used to harvest the energy from the PZT membrane. Another unique characteristic of this power source in ambient conditions is that it outputs relatively low output voltages when low levels of input vibration are encountered. Thus the low output voltage obtained makes it challenging task to develop an efficient rectifier circuits because of nonzero turn-on voltages available in rectifiers. When pressure is applied to the piezoelectric transducer, it conceives deformation in the material. When the piezo strain creates electrical potential difference energy and the voltage is formed. The piezoelectric transducer generates AC output voltage and should be converted to desired dc voltage through the rectifier. To pump the voltage from the rectifier output, DC/DC converter stage is added at the end of the output rectifier for using different applications. The generalized piezoelectric energy harvesting block diagram is shown in Fig. 2.

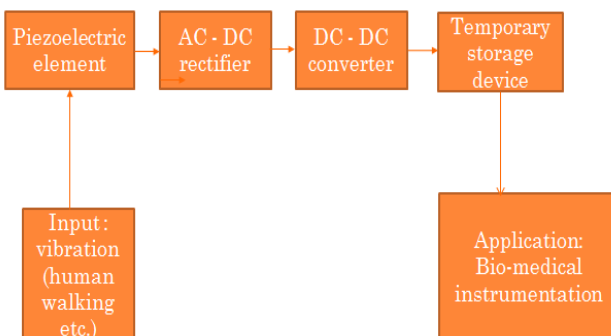

Fig. 2: General block diagram of piezoelectric vibrational energy harvesting system

3. Conventional Rectifier Model

The full wave bridge rectifier circuit is based on four diodes with a smoothing capacitor and a storage element like a battery or resistive load as shown in Fig. 3. In the open circuit piezoelectric transducer, the absolute voltage value is lower and depends on the type of transducer and number of piezo transducers used for the particular applications. In the conventional rectifier, positive and

negative splits are functioning by two pairs of diodes. The output signal produced by the rectifier is a DC voltage, but it is pulsating DC. Smoothing Filter is added parallel to the output load.

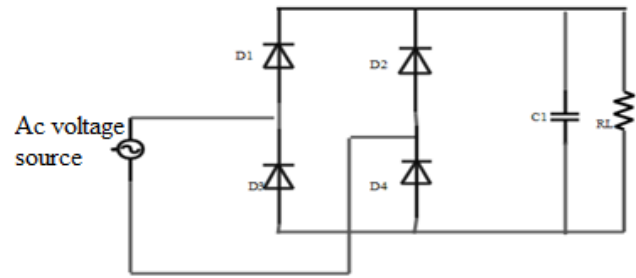

Fig. 3: Conventional circuit of full wave bridge rectifier

4. Proposed Method

The circuit for piezoelectric energy harvesting is generally based on the full wave bridge rectifier circuit model. Due to the conversion of rectifier low AC/DC output voltage it becomes insufficient for driving application uses. So, double stage energy harvesting circuit having first stage has rectifier and followed by converters i.e. step up converter DC/DC is needed. The proposed rectifier circuit is modified with an inductor which is connected with a series capacitor and the diode is connected in parallel to the series combination of inductor and capacitor. It will gain a rectifier output voltage and current and compared to the classic rectifier Piezoelectric energy harvesting output voltage and current. To double the voltage, the generalized dc/dc converter is added at the end of the rectifier output. The voltage and the current values are more comparable to the rectifier output and are shown in the Table 1.

Table 1: Comparison table of between conventional rectifier with proposed energy harvesting rectifier

AC voltage	Conventional rectifier			Proposed energy harvesting rectifier		
	(AC-DC) Output voltage(V) single stage(rectifier)	(DC-DC) Output voltage (V) Double stage (rectifier + converter)	DC Current (A)	(AC-DC)Output voltage(V) single stage(rectifier)	(DC-DC)Output voltage (V) Double stage (rectifier +converter)	DC Current (A)
5	3.325	8.886	0.0889	3.415	10.19	0.1019
6	4.303	11.88	0.1188	4.407	13.58	0.1358
7	5.281	14.87	0.1487	5.405	16.97	0.1697
8	6.26	17.86	0.1786	6.406	20.36	0.2036

The circuit was simulated in a MATLAB-SIMULINK. The generalized block diagram of the proposed system consisting piezoelectric transducer outputting an AC signal is represented in the Fig. 4(a). In the piezo-transducer voltage starts from mill volts to volts. The ac signal is not possible to apply to the load because of the wide frequency range. Generalized inputs is given in the SIMULINK model as shown in Fig. 5 and are rectified by the proposed modified rectifier bridge ac to dc converter. The inductor based rectifier converter is capable of improving more voltage and current values. It is inferred that the proposed piezoelectric rectifier output is much improved than the classic one in terms of significant improvement in voltage and current. The stored energy is applied generally to small scale electronics applications.

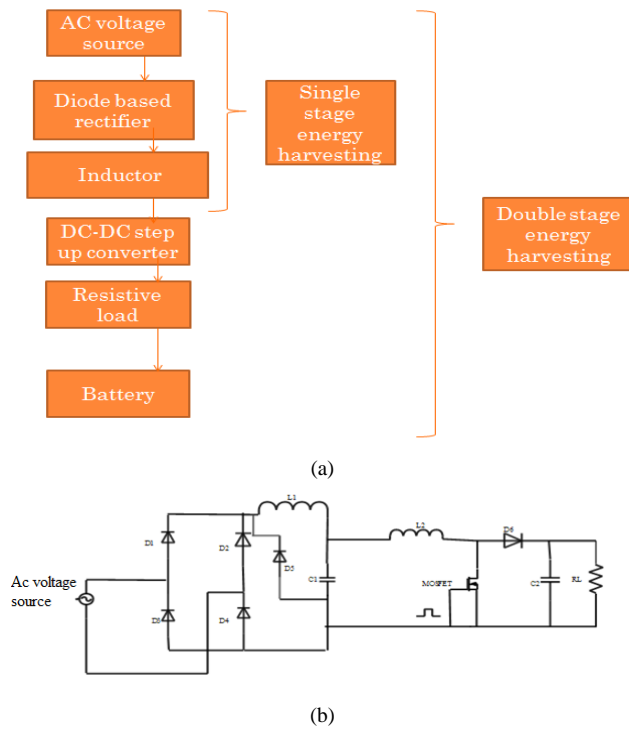

Fig. 4: (a) Block diagram of the proposed double stage energy harvesting system (b): circuit of proposed modified rectifier with step up boost converter

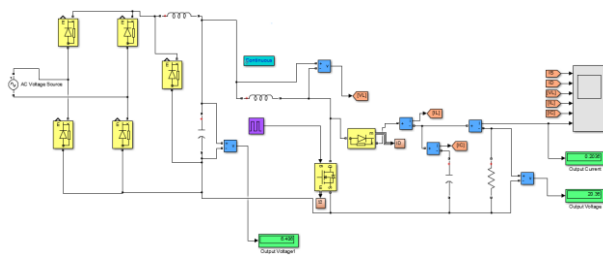

Fig. 5: Simulink diagram of proposed energy harvesting method

5. Simulation Results

The performance of classic rectifier and the proposed are compared and summarized in Table 1. The proposed rectifier with double stage energy harvesting circuit exhibits improved voltage and also the current value in milli amps. Compared to classic rectifier, the much better efficiency has been achieved in the proposed rectifier circuit. From the simulation graph shown in Fig. 6(a), the Classic rectifier double stage based piezoelectric harvesting has obtained voltage and current values of 3.325V/0.08886 amps respectively for the input range of 5V with frequency 50 Hz. On the other hand, from figure 6(b), it is evident that the Modified double stage based energy harvesting circuit was obtained a voltage and current value as 10.19 V/0.1019 amps, for the same input voltage 5V.

6. Conclusion

A theoretical model of the piezoelectric energy harvesting circuit using the full-wave rectifier circuit has been presented and analyzed through the simulation. It is been analyzed that the energy harvested through piezoelectric materials provides a cleaner way of power generation for low power equipment. When single stage energy harvesting circuit is simulated in the MATLAB, the output ranges in positive values. As suggested above, the purpose of dual stage energy harvesting system is boosting the output. The output of the single stage energy harvesting obtained was 3.415V with the input of 5 AC voltage source. But in the improvised circuit called double stage energy harvesting, the voltage obtained was

10.19V and current was 0.1019 amps with the input of 5AC voltage source. Throughout the proposed energy harvesting circuit, the voltage and current values are positively obtained as compared to classic interface piezoelectric rectifier energy harvesting circuit. In the future work, the parameter values for both single and double stage energy harvesting circuits may be properly identified with a millivolt range and given to the input of the small scale electronics application. Due to the forward voltage drop in the PN junction diode, by replacing a diode based rectifier circuit as schottky diode and MOSFET switching device, a much better performance may be achieved.

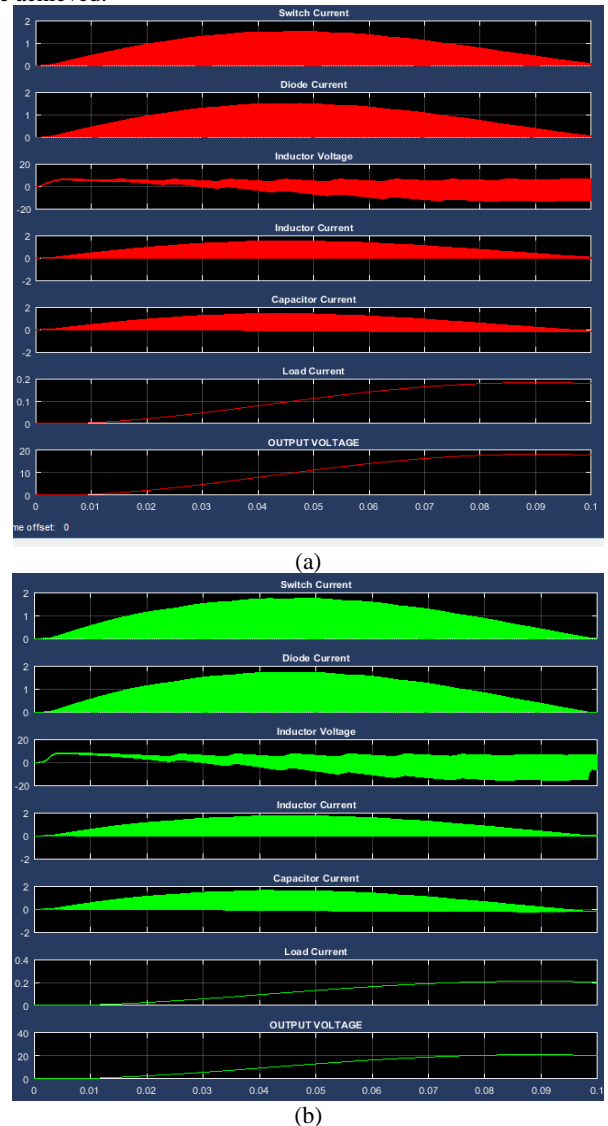

Fig. 6: (a) Simulink graph of conventional rectifier (b) Proposed rectifier for the energy harvesting graph

References

- [1] S.P. Beeby, D.Zhu (2015). Vibration energy harvesting: fabrication, miniaturization and applications. *SPIE Microtechnologies, Barcelona*, ES.8.
- [2] K A Cook-Chennault, N Thambi and A M Sastry (2008). Powering MEMS portable devices- a review of non- regenerative and regenerative power supply systems with special emphasis on piezoelectric energy harvesting system, *Smart Material Structure*.1.7, 1-33.
- [3] Faurk Yilidz (2011). Energy harvesting from passive human power, *Journal of applied science and engineering technology issue 4*.
- [4] S.Lu, F.Boussaid (2015). A Highly efficient P-SSIH rectifier foe piezoelectrci energy harvesting. *IEEE Transactions on power electronics* 30(10), 53645369.
- [5] Y. Kushino, H. Koizumi (2014). Piezoelectric energy harvesting circuit using full wave voltage doubler rectifier and switched induc-

- tor. *IEEE Energy conversion congress and exposition (ECCE), Pittsburgh, PA*. 2310-2315.
- [6] Y. Sun, I.Y. Lee, C.J. Jeong, S.K. Han, S.G. Lee (2011). An comparator based active rectifier for vibration energy harvesting systems. *13th Inter. Conf. on Advanced Communication Technology (ICACT), Seoul*. 1404-1408.
- [7] G.K. Ottman, H.F. Hofmann, A.C. Bhatt and G.A. Lesieutre (2002). Adaptive piezoelectric energy harvesting circuit for wireless remote power supply. *IEEE Trans. Power Electron, vol.17, no.5, pp.669-676*.
- [8] G.K. Ottman, H.F. Hofmann, A.C. Bhatt and G.A. Lesieutre (2003). Optimized piezoelectric energy harvesting circuit using step-down converter in discontinuous conduction mode. *IEEE Trans. Power Electron, vol.18, no. 2, pp. 696-703*.
- [9] J.R. Liang and W.H. Liao (2009). Piezoelectric energy harvesting and dissipation on structural damping. *J.Intell. Mater.Syst. Struct. Vol. 20, no.5, pp. 515-527*.
- [10] Jinhaoqiu, Haojiang, Hongliji, Kongjumzhu (2009). Comparison between four piezoelectric energy harvesting circuits. *Front. Mech.Eng.China, 4(2)*. pp. 153-159.
- [11] A. Tabesh and L.G. Frechette (2010). A low power stand-alone adaptive circuit for harvesting energy from a piezoelectric micro power generator. *IEEE Trans. Ind. Electron. Vol.57, no.3, pp. 840-849*.
- [12] S. Roundy, P.Wright and J.Rabaey (2003). Energy scavenging for wireless sensor networks with special focus on vibrations. *Boston, MA. Kluwer Academic*.