

Survey on Neuro-Fuzzy Based Single Phase Multi-Level Inverters Using FPGA

Ameer Ahamed Z^{1*}, Anuj Jain²

¹Research Scholar, ²Research Guide,

^{1,2}Department of Electronics and Communication Engineering, Bhagwanth University
Ajmer, India

*Corresponding Author E-mail: ¹ameerahamed007@gmail.com, ²a1978jain@gmail.com

Abstract

In the Power electronic converters harmonic reductions is the main issue which will affect the power factor which intern affects power quality. The multi-level inverters here studied the inverter switches strategy is controlled by FPGA technique and the space vectors are assigned using the NN strategy, a survey is made on different types of multi-level inverters which is controlled using FPGA and NN. In this paper a survey is done on Multi level inverters using different control techniques to know how far FPGA and NN is better in performance for power electronic applications.

Keywords: FPGA, Neuro Fuzzy(NF), Neural Networks(NN)

1. Introduction

In the Power electronic converters harmonic reductions is the main issue which will affect the power factor which intern affects power quality. When there is a low power factor the availability of power to the grid will be less, the low power intern causes EMI which will affect the power quality between different systems connected to the same grid. When we go for several applications such as UPS and inverters there should be fast response. The use of microcontrollers is one of the best methods, which is flexible straight forward in designing hardware. The survey is carried out to represent a digital controller which can be applied to single phase inverters. The pulse width modulation technique is used in which the a comparison between the carrier wave and a sinusoidal input, which intern used to drive the power switches, here the pulses produced using the FPGA technique, which is a programmable device.

A. Disadvantages of Microcontroller and DSP

The digital motors are controller and implemented widely using Digital Signal Processing or microcontrollers in many industries, but these two facing problem with long development period and poor portability of software. If any changes needed or to add any extra feature there will be huge procedure with huge revision of the project to match the new system. PWM generation and current control loop requires high sampling rate to achieve wide band width performance and for that purpose most of the computational resources of the controller must be utilized. The drive is controlled but should be controlled in a limited time. A new design methodology that can satisfy these demands are Field Programmable Gate Array, finds the application in high speed switching/high speed digital motor control algorithm, but these are

costly, but these designs are very simple and advantageous, hence these are considered rather than the cost.

The fuzzy logic controller gives better for steady state output voltage with non linear loads whereas PID controller is well suitable for linear loads [10]. The FLC gives the efficient output, accordingly the fuzzy logic controller is made combined with the FPGA, and hence these together give best performance for the controlling of switches in which PWM pulses are produced, by using MATLAB-Simulink software. In Power electronic controllers the PWM control is more efficient and simple method for the control of analog systems used in digital processors. According to The research paper published by IJER journal is about Pulse Width Modulation Implementation using FPGA and CPLD ICs 1 Pulse Width Modulation Implementation using FPGA and CPLD ICs [11].

B. Neuro-Fuzzy Implementation Using FPGA

The control technique used in inverter is based on FPGA which here generates PWM pulses are discussed: The FPGA control is advantageous for controlling of PWM inverters, here the FPGA based inverters are obtained by a verilog/VHDL programming with a Xilinx software. The DSP processor here used as a co-processor in AC-voltage regulation[3]. The Neural networks based SVM for different levels of inverters is designed and implemented using hardware, these NN are independent of switching frequencies [4]. The NFC and FPGA controller used in the implementation of 5 level inverter or PWM inverters, in which the modulation index is was selected by calculating the required DC-bus voltage of a active filter through a digital controller.

2. Multi Level Inverters

A. Three Level Inverter

Figure 2.0 shows the circuit of NPC inverter, here IGBT's are series connected, the input voltage applied is one half of the input voltage applied for the two level inverter. The bus voltage divides equally in series which is connected to bus capacitors and each leg held's 2 clamping diodes.

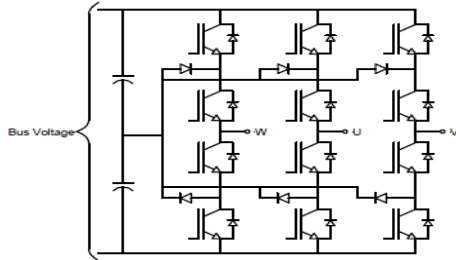

Fig. 2: NPC Inverter

This It is used in the medium voltage drive application, which is having capacity of handling higher voltages. The NPC inverters is high advantageous with lower line to line voltage, common mode voltage strips and lower current ripple for the switching frequency same as that of two level inverter.

B. Output Voltage and Switching States

The NPC inverter has three levels of output, positive DC voltage, and negative DC voltage (Refer to Figure 2.1 for the following example.), and a zero voltage (For Three level inverter), where in two level positive DC voltage and negative DC voltage, here the first and second (Q1 and Q2) are turned ON for positive DC voltage, second and third IGBT (Q2 and Q3) are turned ON for the zero voltage output and thus for (Q3 and Q4) are turned ON for negative DC voltage. Table 1 has a list of switching states of four IGBTs. Clamp diodes diode 4 and 5 (D4 and D5) builds the connection to the neutral point.

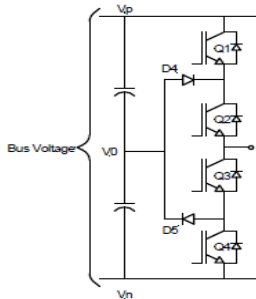

Fig. 2.1: Single leg Inverter

Table 1: Switching States

IGBT	Vout = Vp	Vout = V0	Vout = Vn
Q1	On	Off	Off
Q2	On	On	Off
Q3	Off	On	On
Q4	Off	Off	On

The capacitors are connected in the circuit both in series and parallel to maintain the voltage balance between the capacitors, NPC capacitors is important factor in NPC topology.

Figure 2.2 shows the leg output voltage and Figure 2.3 phase to phase output voltage, here phase to phase voltage is of figure 2.3 is twice that of phase voltage in figure 2.2.

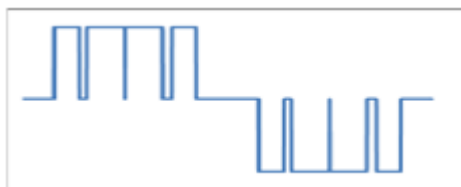

Fig. 2.2: Leg Output Voltage

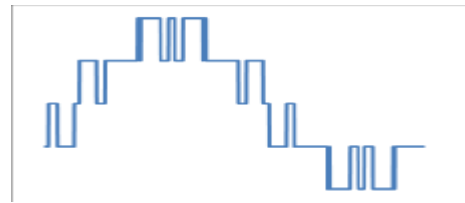

Fig. 2.3: Phase to Phase Output Voltage

C. Diode Clamped Inverter

The diode clamped three level inverter system will be analyzed. The circuit to be investigated theoretically and experimentally is the one depicted in figure. This type of inverter corresponds to a three level topology which means that the output voltage from one inverter leg, measured using the DC midpoint, M, as a reference, can get three different values, a positive voltage, +UDC, a negative voltage, -UDC and a zero voltage or state. The single phase equivalent circuit of the diode clamped three level inverter can be found in figure, where only the one inverter leg is depicted. Below in figure a three phase diode clamped inverter. The principle of operation of the inverter can be clearly elucidated. Having two different current directions, positive and negative, and three different output voltages it is deduced that six current paths are available. In the above figure the current path depends on the state of each switch of the inverter. Below the current path is further explained for both current directions, positive and negative where, the components names are based on figure 2.4.

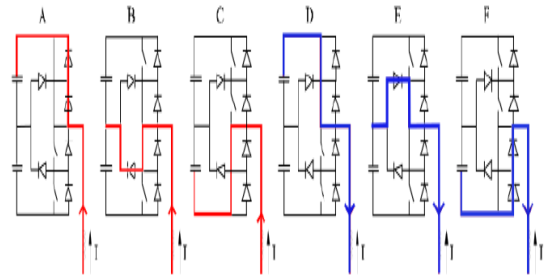

Fig. 2.4: The current paths of diode clamped inverter

- 1) Positive Current Direction:
 - When the switches, S1 and S2 are turned-on the current is flowing through the freewheeling diodes, S1 and S2, and reaches the positive side of the capacitor. The measured output voltage is VDC.
 - a) When the two middle switches, S2 and S3, are turned on, current initially flows through the collector of the lower switch, S3, and eventually through the lower Clamped diode, D1, reaches the DC midpoint. The measured output voltage is 0.
 - b) When the two lower switches, S3 and S4, are turned on current flows through the collectors of the two IGBTs and eventually reaches the negative plate of the capacitor C2. The latter yields a voltage output -VDC.
- 2) Negative Current Direction:
 - a) When the two upper switches, S1 and S2, are turned on, the current originates from the upper capacitor, C1, and flows through the collectors of the IGBTs towards the output. The latter gives a positive DC voltage VDC.
 - b) In this state, the two middle switches, S2 and S3 are turned on and the current runs from the DC midpoint through the upper clamped diode, Dc11 and through the collector of S2 to the output. The measured output voltage is 0.
 - c) In this state the two lower switches, are turned on. The current runs through the free-wheeling diodes of, S3 and S4, to the output and the measured voltage is negative, VDC.

D. Power Inverters and Converters

Generally speaking an inverter is can be defined as an electrical device which converts the direct current, DC, to alternating current, AC. This property of the inverters appoint them very useful for the cases where AC power is not available. Examples include operating appliances in mobile homes as well as audio, video and computing equipment in remote areas. The principle of operation of an inverter is based on the “inverter leg”. Its principal construction. As it can be seen, using a pair of IGBT units the DC power can be easily converted into AC power. The inverter leg consists of two controllable semiconductors S1 and S2, in this example two IGBT units are shown, with their corresponding free-wheeling diodes.

E. Five Level Inverter

The below figure shows the five level inverter, the five levels are obtained by number of cells required which is n-2 as shown in figure 2.5. The voltages $V_1=V_2=V_{dc}$, there are mainly two dc link voltages V_{dc} and $2V_{dc}$ in that it is divided into 5 levels $0.5V_{dc}$, V_{dc} , 0 , $-V_{dc}$, $-0.5V_{dc}$. The zero stage of output is obtained by switching the upper and lower switches together [12]. The other four states can be generated from the dc bus voltage V bus based on folded cascade unit operation, the below figure shows conventional single-phase five-level inverter diagram. The switching states are listed in table 2 as shown below. The PWM method is used here in which one modulating signal and two carrier comparison id done to generate the pulses.

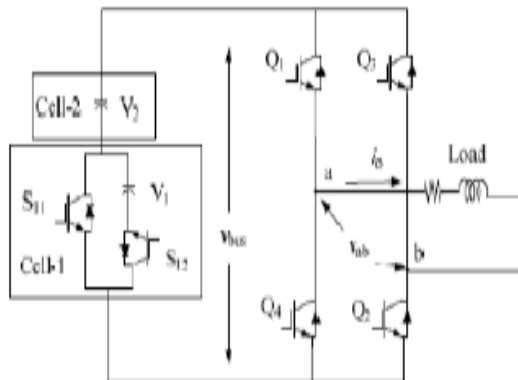

Fig. 2.5: Conventional single-phase Five-level inverter configuration

Table 2. Switching States and direction of output current

V_{dt}	Switching states					
	Q_1	Q_2	Q_3	Q_4	S_{11}	S_{12}
$+V_{dc}$	ON	ON	OFF	OFF	OFF	ON
$+0.5 V_{dc}$	ON	ON	OFF	OFF	ON	OFF
0	ON	OFF	ON	OFF	OFF	OFF
0	OFF	ON	OFF	ON	OFF	ON
$-0.5 V_{dc}$	OFF	OFF	ON	ON	ON	OFF
$-V_{dc}$	OFF	OFF	ON	ON	OFF	ON

3. F.P.G.A

A. Advantages of FPGA

In Power electronic applications usually Field Programmable Gate Array (FPGA) are preferred due to its high switching frequency. They are basically interconnection between different logic blocks. The FPGA design is having reprogrammable capability which will be helpful in adding characteristics in future. Here by changing the

interconnection between these logic blocks. FPGA technique plays vital role in industries, associated with manufacturing of the processors. FPGA along with Xilinx are user programmable. The data loading and programming can be referred as configuration. FPGAs load automatically from external processors easily, The FPGA, Spartan-3E, is used here which can be downloaded and can be programmed by some external sources. The external sources are microprocessors, microcontrollers and DSP processors. In all cases serial communication is used for the transfer of data path, because it requires less pin for transferring, hence it is fully considered.

B. Programming the FPGA, CPLD

The Design finds the application i. hazardous situations; hence it is widely used in real time outputs, especially in the operation of nuclear, aircraft and communication systems.

In the FPGA 8-bit sinusoidal input is used, which can be compared with the triangular wave. The triangular wave is generated by programming with external clock; when it reaches the maximum value of clock that is at 255, the clock is reset, hence the triangular wave compared with sinusoidal bit steam to generate PWM pulses, which are used to drive the switches, which intern produces the inverter output.

The efficient switching sequence is provided by designing the pulses with different phase shift depending upon the levels of inverters designed.

4. Neuro Fuzzy Logic

A. Neural Networks

The Neural networks functioning are to shape out the biological functioning of the human brain, the neural networks can be learnt with training vectors, input and output samples of the systems.

The main functioning of neural networks is to build a connection between artificial neuron by modifying the internal structure, to make the mapping with a output of acceptable error, in comparison with the input/output, which represents the behavior of the system.

- 1) Fuzzy Systems: It propose a mathematic calculus in which the fuzzy logic rules are applied to translate the subjective human knowledge of real processes.
- 2) Neuro-Fuzzy Systems: The combination of fuzzy logic and neural networks is called neuro-fuzzy systems.

Neuro-Fuzzy System (NFS) = Neural Network (NN) +Fuzzy Logic (FL)

5. Conclusion

Many intelligent control techniques are developed such as fuzzy logic, Proportional Integrator Derivative, Neural Networks and also FPGA control are developed to obtain high performance; here we are using FPGA control technique for obtaining PWM pulses required for inverters since it has shorter design cycle, low cost and higher density. During hardware implementation the Neural Network (NN) based Space vector modulation (SVM) is used for inverters which is independent of switching frequencies. The Research objective is, The fuzzy logic control is applied for single phase Multi-level inverters to reduce the harmonic contents, An FPGA based NFC single phase multi-level inverters are designed and the co-simulation can be done by MATLAB simulink and Modelsim. The fuzzy control can be applied by a optimal setting of membership function and the combination of Neuro-Fuzzy is used to design the PWM inverters used for ac power conditioning and also the proposed digital controller has been realized by an FPGA from Xilinx.

References

- [1] Fatih Korkmaz, Smail Topaloglu and Hayati Mamur "Fuzzy logic based direct torque control of induction motor with space vector modulation", International Journal on Soft Computing, Artificial Intelligence and Applications (IJSCAI), Vol. 2, No. 5/6, December 2013.
- [2] Pawel Z Grabowski, Bimal K Bose and Frede Blaabjerg "A simple direct torque neuro-fuzzy control of PWM-inverter-fed induction motor drive", IEEE transactions on industrial electronics Vol.47, No.4, August 2000.
- [3] M. Valan Rajkumar, P. S. Manoharan "Space vector pulse width modulation of three phase DCML1 with neuro fuzzy MPPT for Photo voltaic systems" ISSN 1 746-7233, England, UK World Journal of Modelling and Simulation Vol. 10 (2014) No. 3, pp. 193-205.
- [4] S. Lisauskas, D. Udris, D. Uznys "Direct torque control of induction motor drive using fuzzy controller", ELEKTRONIKA IR ELEKTROTECHNIKA, ISSN 1392-1215, VOL. 19, NO. 5, 2013.
- [5] C.Vignesh, S.Shantha Sheela, E.Chidam Meenakchi Devi R.Balachandar, "Direct torque control of induction motor using fuzzy logic controller", International Refereed Journal of Engineering and Science (IRJES) ISSN (Online) 2319-183X, (Print) 2319-1821 Volume 3, Issue 2 (January 2014).
- [7] C.Bharatiraja, R.Latha "A 3 - Dimensional SVPWM algorithm, its FPGA - implementation for multilevel inverters" Journal of Electrical Engineering.
- [8] V.Kumar Chinnaiyan, Dr.Jovitha Jerome and J.Karpagam, Member IEEE "An FPGA Based Control Algorithm for Cascaded Multilevel Inverters", IACSIT International Journal of Engineering and Technology Vol.1, No.5, December, 2009 ISSN: 1793-8236.
- [9] A. Dinesh Babu, B. Bhuvanewari, P. Priya and S. Lakshmi Shankar "FPGA Based Design and Implementation of Low Cost High Performance Generalised Cascaded Asymmetric Multilevel Inverter" I J C T A, 9(15), 2016, pp. 7221-7234 © International Science Press.
- [10] K.R.Rekha, Shalini Vashishtha "Survey on FPGA Based Space Vector PWM Motion Control", IJAREIE ISSN (Print) : 2320 – 3765 10.15662/ijareie.2015.
- [11] Aasha Chauhan, Dr. Ravindra Pratap Singh "A STUDY PAPER BASED ON SPACE VECTOR PULSE WIDTH MODULATION TECHNIQUE FOR POWER QUALITY IMPROVEMENT", International Journal of Science Technology & Management Volume No.04, Special Issue No.01, February 2015 ISSN 2394-1529.
- [12] Qamar Muhammad Attique, Yongdong Li, and Kui Wang, "A Survey on Space-Vector Pulse Width Modulation for Multilevel Inverters", CPSS TRANSACTIONS ON POWER ELECTRONICS AND APPLICATIONS, VOL. 2, NO. 3, SEPTEMBER 2017.
- [13] Vijay Y. Patil and V.V.Patil, "Multilevel Inverters – A Survey", International Journal of Current Engineering and Technology E-ISSN 2277-4106, P-ISSN 2347-5161 at 2015.