

Density Based Traffic Light Controlling System using IOT

K. Bhagavan¹, B Yaswitha Reddy², T Krishna Sujay³, T Sravan Kumar⁴

^{1,2,3,4}Dept of CSE, K L E F, Vaddeswaram, India

*Corresponding author E-mail: bhagavan@kluniversity.in

Abstract

The present existing frameworks do dominant the traffic becomes major issue owe to fast increase in vehicles and conjointly owing to giant time lag between the traffic lights. So, so as to improve the downside, I am going to opt for the effective traffic lights system using Density technique. This paper illustrate you how to manage traffic density. During this scheme, the sensing are adopted to live traffic substantially. we rearrange one LDR sensing element for each one road; these Light Dependent resistors sensors forever the traffic thereon specific roadway. of these LDR sensors are interfaced with micro controller. Supported controller & Sensors recognize traffic after that traffic system has been controlled.

Keywords: Microcontroller, GSM SIM 900A, LCD display, LDR.

1. Introduction

In modern life we've got to face with several issues one in all that is hold up changing into additional serious day when day. it's aforementioned that the high volume of vehicles, the inadequate infrastructure and also the irritational distribution of the event area unit main reason for increasing traffic congestion. once traffic demand is nice that the interaction between vehicles slows the speed of traffic stream, these leads to some congestion. This paper largely concentrates on the safety of a home once the shopper is way from the place. 2 frameworks area unit planned, one depends on GSM innovation and totally different uses internet camera to tell apart the intruder. The principal security framework utilizes an online camera, introduced in house premises, that is worked by programming introduced on the computer and it utilizes net for correspondence. The camera identifies movement of any unwelcome person before the camera measurements or camera run. The merchandise conveys to the planned shopper through net organize and within the meanwhile it offers sound alarm. The second security framework is SMS based mostly and utilizes GSM innovation to send the SMS to the man of affairs. The planned framework is gone for the safety of Home against Intruders and hearth. In any of the higher than cases happens whereas the proprietor's area unit out of their home then the gizmo sends SMS to the crisis variety that is given to the framework. The framework is comprised of 3 segments: sensors, GSM (sim548c), At89s52 microcontroller, transfers to manage the gizmo and bells to convey security prepared flag as way as sound.

2 Block Diagram and Modules Description

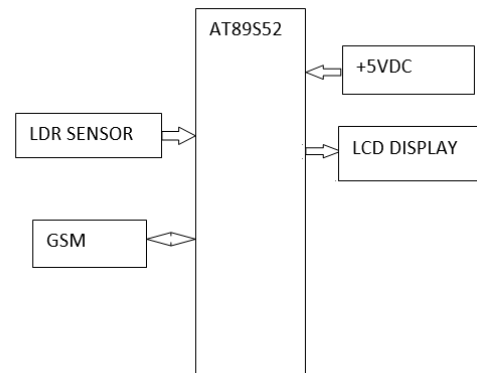

Fig1: block diagram

1. Modules and Description 1. AT89S52 Micro controller

AT89S52 microcontroller board is predicated on a 8-bit microcontroller with period emulation and embedded trace support, that mix microcontrollers with embedded high-speed memory board eight K and 256 bytes of data RAM32 I/O lines, 3 16-bit counters/timers, one full duplex pin/port and 2 level 8 vector interrupt style, on-chip generator, and clock equipment.

In addition, the AT89S52 is supposed with a static logic for progress right drop to 0 frequencies and shores one software pair package preferable power save mode. In this idle mode the C.P.U stopped. Whereas concede Counters / timer, RAM, interrupt system and a port running the function. The ISP (serial in system programming, parallel algorithm supported by flash program memory. The IAP, allowing the Flash application reminiscence to be reconfigured even whereas the making use of is jogging in addition to 89S52.

The combination of Flash on a chip and 8bit C.P.U. with, the Atmel AT89S52 which is the robust laptop computer. Gives a very versatile and value effective answer to many embedded management applications.

2. Features of AT89S52 Micro Controller

- Non volatile storage of an 8 kilo bytes of In System Re programmable.
- Absolutely Static Operation: from 0 cps to the 33 rate.
- 3 Level Programmed Memory Lock.
- 256x8 bit RAM (internal). 32 I/O lines which are Programmable. 3 16-bit timer / counters. Interrupt sources count of six.
- A Serial channel which is Programmable.
- Model of Idle Low power, Power down, 4.0volts to 5volts in operation vary.
- UART Serial Channel (Full Duplex). Watchdog timer. Twin knowledge Pointer and quick programming time.

3. Power Supply –

At low DC Voltage, **every** electronic circuits work very solely in low DC voltage, therefore I'd like an influence provide unit {to produce} the suitable voltage supply for his or her correct operating. It having of , rectifier, electrical device, a regulator & a filter;. Generally a 230 volts RMS AC voltage of generally 230volts RMS and an electrical device voltage combined all the way reduce, to the extent to the required ac voltage which required. The diode which is acts as rectifier gives a complete waveform corrected the voltage it's filtered with the help of DC voltage and straightforward capacitive filter. It ensuring the direct current voltage typically has few disturbances / ac voltage ripples or variation. The typical electrical circuit will utilize available direct current (DC) input to produce DC voltage which not absolutely having a lot of lower ripple voltage however conjointly remainder a similar DC worth although DC voltage somewhat varies, or the O/P DC voltage changed where the load connected.

4. Transformer –

The transformer is the static segment where the power, in a electrical circuit is remodeled into a power of the same frequency in an another electric circuit. The Transformer increases / decreases a voltage within one circuit, however similar raise or less in the current also. It works on the principle of a mutual induction. In our proposed system we have tendency for an area unit employing one step down electrical device for giving the necessary thing to an electronic circuit. Here having the tendency to drop out 230volts AC into a 12 volt AC

5. Rectifier:

A dc stable wave recovered from a curving i/p can be enhanced a hundred employing a method known as the full wave rectification. Here in this approach, for getting a fully wave rectification, the bridge wave rectifier used. In the bridge rectifier circuit we tend to use the 2 diodes those are D2 & D3 connected whereas on other side D1 and D4, 2 diodes are in the non conduction state throughout $t = 0$; to $T/2$. Similarly for the next half cycle i.e. negative input the D1 & D4 are in conduction state .Thus the polarity is same across the load. Within this bridge rectifier; we used the variable diodes Such as 1N4005; 1N4007; 1N4004; 1N4003; and 1N4001; etc. Therefore here I tend to utilise 1N4007, as a result of it will stand capable to 1000v

6. Filters:

For getting a Zero Hertz DC voltage; use an occasional LP (pass filter). Instead of electrical phenomenon filter employed wherever the electrical condenser connects at the output of the rectifier; The DC attain across it. The undulation filtered basically negligible ripples of the DC Voltage & transfers to the output / load.

7. Regulators:

An electrical device o/p voltage additional filtering done & finally it regulated. A transformer could be a electric device, that gives a constable / stable output that is voltage constant regardless modification in offer differences, load differences & difference in temperature. In this, A tendency to use fastened transformer particularly 7805.; which is used as +5v regulator employed to the micro controller.

3. Design Process: Interface of Micro controller & GSM Module:

The Atmega16 micro controller; also connected with the SIM900A GSM Module area unit connected for intercommunica-

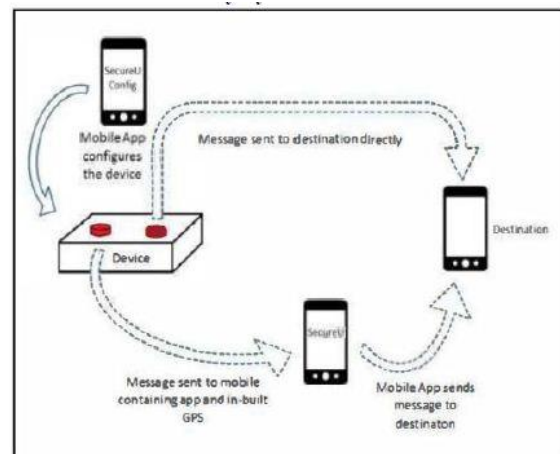

tion purpose with the help of UART circuit gift within an AT89S52. The Receiver Rx (P3.0); and the American state (P3.1) pins of AT89S52 area unit attached with the American state; & GSM Module Receiver severally The GSM Module SIM900A will settle for power offer within the vary nine to fifteen volts. it's battery-powered with a twelve potential unit of the adapter of DC The micro controller of AT89S52 is battery-powered connected to 5 volts power with pin of power output within A GSM Module. A switch /button connection given to the PORT B of the micro controller. This button is employed for causation a message. The data formatting method usually having a baud setting, frame format setting the transmitter / receiver. And that we have to be compelled to match the baud of controller to the baud of GSM module that is 9600. we've got used

Timer one in mode two by setting T MOD register 0x20 and better computer memory unit of Timer one 0xFD to induce the baud of 9600. Also S CON register is employed to line the mode of serial communication, we've used mode one with receiving enabled. B. causation SMS with the help of GSM Module and a micro controller delivers associate SMS degree within the below functions: one Write Function: S BUFFER is employed for serial communication, Whenever we wish to send any computer memory unit to serial device we tend to place that computer memory unit in S BUFFER register, once the whole computer memory unit has been sent then TI bit is ready by hardware. We want to reset it by causation next computer memory unit. It's a flag that indicates that computer memory unit has been sent with

success. TI is that the second little bit of S CON register. We've sent "AT" exploitation this function.

Read Function: Same as sending, whenever we have a tendency to receive any computer memory unit from external device that computer memory unit is place in S BUFFER register; we have a tendency to simply ought to scan it. And whenever the whole computer memory unit has been received RI bit is about by hardware. once ought to reset it for receiving next computer memory unit. RI is that the initial little bit of S CON register. We've got scan response "OK" victimization this function.

4. Conclusion

This project aimed to reduce the existing frameworks which are dominant where traffic becomes major issue owing to fast increase in vehicles and owing to more time lag between the traffic lights to improve the downside, Here we opted for the effective traffic lights system using Density technique. In this scheme, the LDR sensors are used to track live traffic substantially. Rearranging one LDR sensing element for each road; these Light Dependent resistors sensors are used to analyze the traffic there on specific roadway and these LDR sensors are interfaced with micro controller. These Supported controller & Sensors recognize traffic after that traffic system has been controlled.

References

- [1] Anvari-Moghaddam, A., Monsef, H. and Rahimi-Kian, A., "Optimal smart home energy management considering energy saving and a comfortable lifestyle," *IEEE Transactions on Smart Grid*, vol. 6, no. 1, pp.324-332, 2015.
- [2] Wu, Y., Lau, V.K., Tsang, D.H., Qian, L.P. and Meng, L., "Optimal energy scheduling for residential smart grid with centralized renewable energy source," *IEEE Systems Journal*, vol. 8, no.2, pp.562-576, 2014.
- [3] Han, J., Choi, C.S., Park, W.K., Lee, I. and Kim, S.H., "Smart home energy management system including renewable energy based on ZigBee and PLC," *IEEE Transactions on Consumer Electronics*, vol. 60, no. 2, pp.198-202, 2014.
- [4] Jaradat, M., Jarrah, M., Jararweh, Y., Al-Ayyoub, M. and Bousselham, A., "Integration of renewable energy in demand-side management for home appliances," in 2014 International Renewable and Sustainable Energy Conference (IRSEC), October, pp. 571-576, 2014.
- [5] Missaoui, R., Joumaa, H., Ploix, S. and Bacha, S., "Managing energy smart homes according to energy prices: analysis of a building energy management system," *Energy and Buildings*, vol. 71, pp.155-167, 2014.
- [6] FitzPatrick, G.J. and Wollman, D.A., "NIST interoperability framework and action plans," in *IEEE PES General Meeting*, July, pp. 1-4, 2010.
- [7] Garner, G., "Designing Last Mile Communications Infrastructures for Intelligent Utility Networks (Smart Grids)," IBM Australia Limited, 2010.
- [8] Al-Omar, B., Al-Ali, A.R., Ahmed, R. and Landolsi, T., "Role of information and communication technologies in the smart grid," *Journal of Emerging Trends in Computing and Information Sciences*, vol. 3, no.5, pp.707-716, 2012.
- [9] Gungor, V.C., Sahin, D., Kocak, T., Ergut, S., Buccella, C., Cecati, C. and Hancke, G.P., "A survey on smart grid potential applications and communication requirements," *IEEE Transactions on Industrial Informatics*, vol. 9, no.1, pp.28-42, 2013.
- [10] Huang, Z. and Yuan, F., "Implementation of 6LoWPAN and Its Application in Smart Lighting," *Journal of Computer and Communications*, vol. 3, no.3, p.80, 2015.