

Optimal 2-DOF PID controller design for load frequency control with various nonlinearities

Tarakanta Jena¹, Manoj Kumar Debnath^{1*}, Prateek Prasad Ray¹, Smaran Kumar Sanyal¹

¹ Siksha O Anusandhan University, Bhubaneswar, Odisha, India

*Corresponding author E-mail: mkd.odisha@gmail.com

Abstract

This article includes an efficient and effective hybrid optimization technique called as Differential Evolution - Particle Swarm Optimization (DE-PSO) is used to optimize the controller gains parameters of two-degree of freedom-proportional-integral-derivative controller (2-DOF-PID) by considering the Integral time absolute error (ITAE) in load frequency control of three area non-linear interconnected reheat thermal system. The nonlinearities of the system are implemented by generation rate constraints (GRC) in each of the control areas. The incomparability of the suggested method is recognized above some pre-published outputs. The domination of 2-DOF-PID controller in conditions of responses of the settling time, minimum undershoots & overshoot over other controllers is proved on the nonlinear system. For the verification of the robustness of the mentioned controller a time delay is introduced in the scrutinized system as a second source of nonlinearity.

Keywords: 2-Degree Freedom of Proportional-Integral-Derivative Controller; Load Frequency Control, Differential Evolution; Particle Swarm Optimization; Nonlinear System.

1. Introduction

At present, due to the load frequency control the procedure of interconnected power systems is achievable and has achieved significance by means of the development of interconnected power systems. To have a successful maneuver of interconnected power systems, it necessitates balancing the complete amount of generation of power with the total demand in load plus the losses allied with the system. During the normal condition as well as in case of a very minute variation in the load, the Automatic generation control (AGC) helps in maintaining the frequency to its desired value and the transfer of power in their planned value [1]. The aim of the control strategy is to not only deliver power to the system but also to generate power in an interconnected power system that too as inexpensively and consistently as possible. It also aims to do so while keeping the voltage and frequency within acceptable limits. The real power and the frequency of the system are controlled by the load frequency control loops of the system [2].

Many control strategies are introduced recently over the past few decades in the interconnected linear as well as nonlinear power system to develop the performances of the system. S. Mishra and C.N. Bhende investigated in their paper [3] about BFO technique which is based on the PI controller, where the results show impressive results in the performance of the proposed controller. In the paper [4], bacteria foraging optimization technique is utilized to tune the controller gain parameters in an unequal three area thermal system and the performance is paralleled with genetic algorithm and the results show that BF algorithm is much faster in optimization. Article [5] examines LFC as well as AGC for both interconnected and isolated power systems and the performance of the proposed FO controllers showed superior output results than classical integer order controllers. An effective control scheme is proposed and applied to solve

the problems related to LFC [6]. The paper [7] investigated the performance of the Differential evolution optimization technique which is applied to tune the 2DOF-PID controller gain parameters of a two area non-linear powers system and the performance is compared with the CPSO technique and outputs show that the proposed controller performs better. Ahmad M Hamza, et al investigated in their paper [8] about the optimization technique called BFO as well as Zeigler method for optimizing the gains of PID controller of LFC along with AVR for a single area system. Paper [9] proposed FOPID controller that is tuned by the imperialist competitive algorithm (ICA) operated on the power system model and the performance is being compared with the conventional PID controllers. In the paper [10] an unequal three area system is presented where it is controlled through the controller 2DOF-PID and 2DOF-PI based on an optimization technique (Firefly algorithm) and the results show that the 2DOF-PID shows better response. Rabindra Kumar Sahoo proposed about the TLBO algorithm i.e., Teaching Learning Based Optimization algorithm in their paper [11]. It was used to tune the 2DOF-PID controller based first on a two area system and then on multi source system. The gains were compared between the different controllers and the output shows that the 2DOF-PID controller optimizes in a better way. The paper [12] investigates about the hybrid optimization technique called as DE-PSO or differential evolution-particle swarm optimization. It is used to optimize the fuzzy-pid controller. The hybrid DE-PSO technique is utilized to optimize the lead-lag controller and the technique is compared with PSO as well as with DE algorithm in the paper [13]. A derivative termed filter along with the PID controller is tuned by the JAYA algorithm in a two area linear system and the result is compared with various different optimization techniques [14]. The paper [15] suggested the 2DOF-PID controller which is tuned by the differential evolution technique basing upon a double area unequal system.

Here we suggested the non-linear power system for LFC using a very superior optimization technique called as DE-PSO which is used to optimize the 2DOF-PID controller.

2. System investigated

Here the investigations have been carried out on the nonlinearities of the systems. The exploration regarding the nonlinear system is carried on a three area thermal reheat power system comprising Generation Rate constraints (GRC) in each area. The parameters for the nonlinear system are considered from the paper [4]. The model of the transfer function of the three area nonlinear reheat thermal system with GRC is exposed in Fig.1. The governor rate constraint per minute is taken as 3%. The outline of 2-DOF-PID controller is presented in Fig.2. The 2-DOF-PID controller is tuned via the hybrid DE-PSO technique for the frequency oscillation observation. The operation and evaluation of the responses were done using the MATLAB version 7.10.0.499 (R2010a). The governor time constant, turbine time constant, reheat and power system time constant is represented as T_G, T_T, T_R & T_p respectively. Biased frequency for each area is denoted by B_i ; the speed regulation of the governor is represented by R and Δf_i denotes the change in frequency in each area.

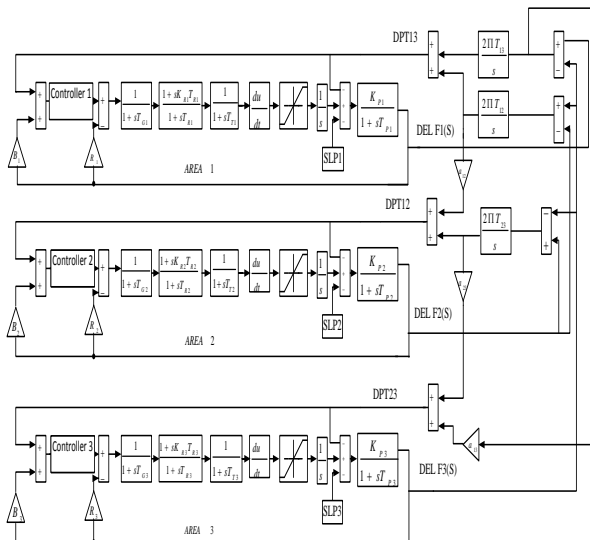

Fig. 1: Three Area Unified System with GRC.

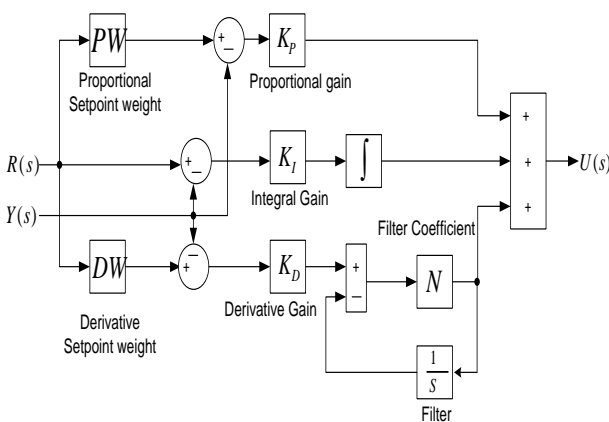

Fig. 2: Outline of 2-DOF PID Controller.

3. Suggested method

3.1. Design of controller

A degree of freedom in the control system is defined as the total number of closed loop transfer functions which can be completely

tuned. The two-degree of freedom (2DOF) controller has more number of advantages than the single-DOF or 1-degree, such as tracking the set point variables very smoothly and rejecting the disturbances which occurs in the system. In a traditional SDOF controller tuning is done according to the load to disturbance condition. SDOF controller also cannot provide with additional flexible condition because the set point weight's performance is not considered unlike the 2DOF controller. An output signal that is generated by the 2DOF controller is the result from the difference between reference signal and the system's output that is measured. The difference in the set point weight signal is calculated for each of the derivative, integral along with proportional actions. The output of the controller is the summation between the derivative actions and also with the proportional and integral actions on their difference in the signals respectively. For the large delays in the transportation of the system and for the period where the system is not required to respond quickly, the derivative mode is removed from the controller. Proportional-Integral with derivative controller (PID) is utilized to give stability to the system and to make the system respond fast. The derivative filter is applied during the errors which are generated randomly and also for the duration of the existence of noise for the improvement of system performance. In the outlined figure (Fig.2) of 2-DOF PID controller, the proportional, derivative as well as integral control gains are denoted as K_p, K_d & K_i , N is coefficient for the derivative filter, PW is proportional set-point weight, DW is derivative set-point weight and $U(s), R(s)$ & $Y(s)$ represent the output's signal, reference signal and system's feedback signal respectively.

3.2. Optimization techniques

3.2.1. Differential evolution

The differential evolution technique is a population centered technique which is very easy to implement and it requires negligible parameter for tuning and it is known for its outstanding property of combinatorial optimization. The three most important parameters are coefficients due to weighting, the crossover probability and DE scheme. The new testing solutions are generated by the usage of the weighting coefficients. To determine about the accuracy of the trial solutions to be implemented on the current solutions the crossover probability is used and finally the DE scheme is used to produce the trial vectors. The detailed investigations about the differential evolution are shown in paper [8].

3.2.2. Particle swarm optimization

The PSO technique was developed by Kennedy and Eberhart in the year of 1995. The Particle Swarm Optimization technique was developed on the source for searching of foods by the flock of birds or by the school of fish. It is a search procedure based on the swarm intelligence. In this method population is referred as swarm. To make the most of the survival of the species, the PSO technique studies the actions of the individuals in the group. All particles have X_i as their position vector, the vector for velocity is represented by V_i and the best solution met by the particle is termed as P_{ibest} . Paper [5] shows the detailed information regarding the Particle Swarm Optimization.

3.2.3. Hybrid depso technique

For each and every particle, there are three updating strategies in the algorithm: first the updating strategy for differential evolution, then the randomly updating strategy and finally the updating strategy for Particle swarm optimization. The algorithm for the hybrid DE-PSO optimization technique is as follows:-

- i) Initialization of randomly generated population i.e. X_{G1} .
- ii) The iteration counter is set up i.e. $j = 1$.

- iii) The objective function directed the computation of the fitness value.
- iv) Differential evolution technique is implemented.
- a) Mutation as well as cross-over operators are used to generate the mutant vectors i.e. X_{G2} .
- b) The new fitness values are calculated.
- v) Particle Swarm Optimization (PSO) is implemented.
- a) The population is initialized as X_{G1} .
- b) Depending upon the individual's fitness value, the best population i.e. P_{best} is generated from X_{G1} .
- c) The global best or the overall best i.e. G_{best} is also found out.
- d) The new velocity is found out and with the help of the newly found velocities the updation of population is done and therefore generating the new population.
- e) The fitness value is found out.
- vi) For finding out the best individual all the fitness values are compared.
- vii) The iteration counter is incremented i.e. $j = j + 1$.
- viii) The loop should be recurring from the step 4 if the end condition is not satisfied.

4. Result and analysis

At first the multi-area system with proper GRCs is examined by comparing the results of 2DOF-PID controller with integral controller. All the nonlinear systems were examined in the MATLAB/SIMULINK software. For optimization of the recommended controllers DE-PSO optimization technique is used with ITAE (Integral Time Absolute Error) as fitness function (Eq.1). The superior convergence of DEPSO over DE and PSO is depicted in Fig.3.

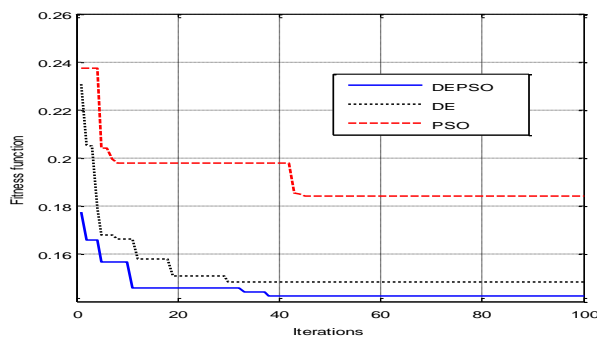

Fig. 3: Convergence Behavior of Different Optimization Methods.

For investigating the frequency as well as the oscillations between inter-line powers, a load disturbance of 1% is applied on area-1. Initially the three area thermal system [4] is considered and the system nonlinearities are included in terms of 3% GRC. The variations of frequencies are denoted as Δf_i and the oscillations due to inter-line power is denoted as ΔP_{tie} . The deviations Δf_1 , Δf_2 , Δf_3 and ΔP_{tie12} are shown in the Fig.4-7 respectively. For the three distinct 2DOF-PID controllers, eighteen controllers parameters are optimized simultaneously. The controller gains of 2DOF-PID optimized by DE-PSO are listed in Table I. The Table II represents the response indices such as peak overshoot, minimum undershoot as well as settling time. The results of the scrutinized non-linear system are compared with the results of paper [4]. It can be concluded from the Fig.4-7 and Table I that the suggested method produces superior performance as compared to existing one in terms of response indices.

$$ITAE = \int (|\Delta f_1| + |\Delta f_2| + |\Delta f_3|) t . dt \tag{1}$$

The expression of fitness function (Eq.1) shows that it is a time dependent combination of frequency variations of each area.

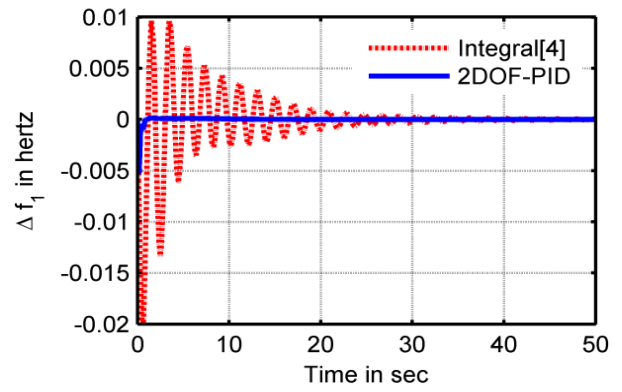

Fig. 4: Frequency Oscillations in Area 1.

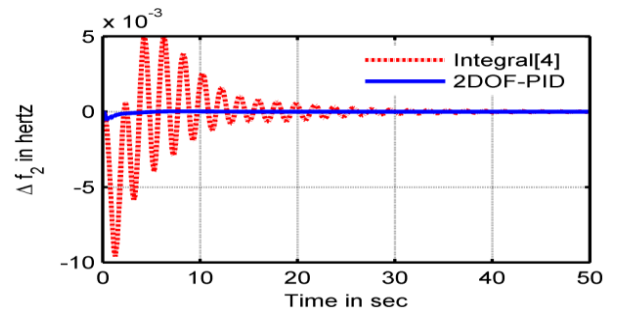

Fig. 5: Frequency Oscillations in Area 2.

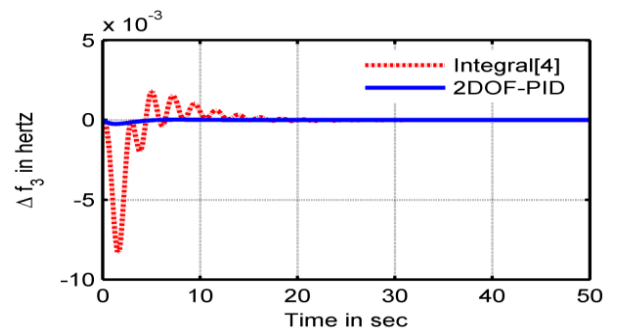

Fig. 6: Frequency Oscillations in Area 3.

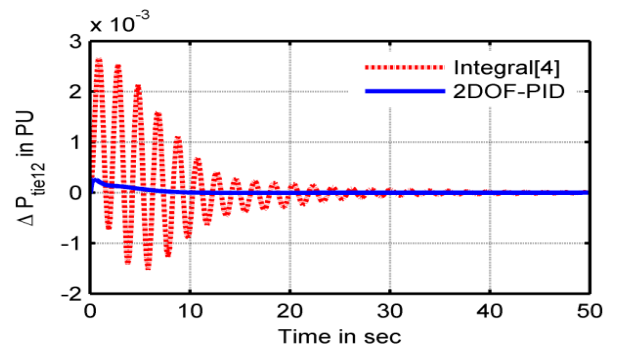

Fig. 7: Tie-Line Power Oscillations between Area 1&2.

In the later case, a time delay is introduced as a second source of nonlinearities in the system. A delay of 0.1s is inserted in each area to investigate the system response with existing controller parameters. The deviations such as Δf_1 and ΔP_{tie12} are depicted in Fig.8-9 respectively. From these figures it can be judged that 2DOF-PID controller shows superior performance as compared other controllers and proves its robustness.

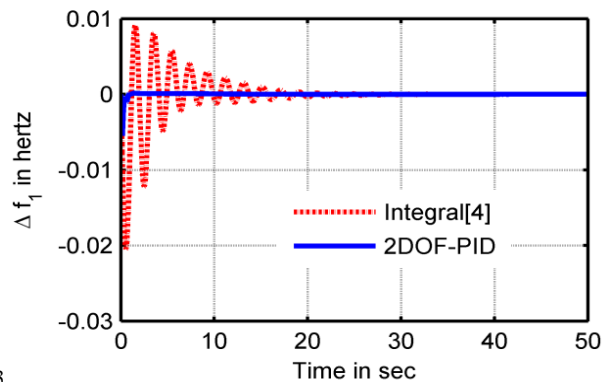

Fig. 8: Frequency Oscillations in Area 1 with Delay.

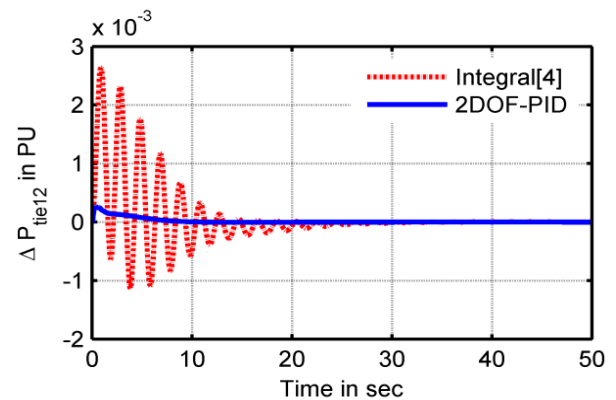

Fig. 9: Tie-Line Power Oscillations with Delay

Table 1: The Finest Value of Gains of 2-DOF PID Controllers Tuned by DEPSO.

Parameters	2-DOF PID Controller			Integral Controller [4]		
	Thermal Area 1	Thermal Area 2	Thermal Area 3	Thermal Area 1	Thermal Area 2	Thermal Area 3
N	150.7720	47.9685	118.1311			
K_p	1.8813	1.8772	1.0530			
K_I	1.8103	1.6691	0.4344	$K_I = 0.4465$	$K_I = 0.2191$	$K_I = 0.2799$
K_D	1.0850	0.8800	1.6717			
PW	4.4386	4.2548	0.7768			
DW	1.1179	3.5214	0.5677			

Table 2: Settling Time, Peak Overshoots and Undershoot

Deviations	Response Indices O_{sh}, T_s & U_{sh}	controllers	
		Integral [4]	2DOF-PID
Δf_1	Overshoot	0.0096	0.0001458
	T_s in sec	25.6986	0.7164
	Undershoot	-0.0199	-0.0053
Δf_2	Overshoot	0.0050	0.0000290
	T_s in sec	20.8329	0.4190
	Undershoot	-0.0096	-0.0006
Δf_3	Overshoot	0.0018	0.0000247
	T_s in sec	21.7752	4.2557
	Undershoot	-0.0083	-0.0002

5. Conclusion

In this analysis the load frequency control is attained by the application of 2DOF-PID controller in the three area non-linear power system and DE-PSO optimization technique is used to control and optimize the parameters. Here the pre-eminence of the proposed method is also found out by comparing hybrid DE-PSO with Bacteria Foraging technique. The responses are also analyzed in terms of undershoot, overshoot and settling time and it was found to be better in hybrid DE-PSO technique with 2DOF-PID controller. By introducing time delay as second source of nonlinearities, the robustness of the system is also confirmed.

References

- [1] Kundur, Prabha, Neal J. Balu, and Mark G. Lauby. Power system stability and control. Vol. 7. New York: McGraw-hill, 1994.
- [2] Saadat, Hadi. Power system analysis. McGraw-Hill, 1999.
- [3] Mishra, S., and C. N. Bhende. "Bacterial foraging technique-based optimized active power filter for load compensation." IEEE Transactions on Power Delivery 22.1 (2007): 457-465.
- [4] Nanda, Janardan, Sukumar Mishra, and Lalit Chandra Saikia. "Maiden application of bacterial foraging-based optimization technique in multiarea automatic generation control." IEEE Transactions on power systems 24.2 (2009): 602-609.
- [5] Alomoush, Muwaffaq Irsheid. "Load frequency control and automatic generation control using fractional-order controllers." Electrical Engineering 91.7 (2010): 357-368.
- [6] Gupta, M., et al. "A Novel Approach for LFC and AVR of an Autonomous Power Generating System." International Conference on Mechanical Engineering and Technology (ICMET-London 2011). ASME Press, 2011.
- [7] Sahu, Rabindra Kumar, Sidhartha Panda, and Umesh Kumar Rout. "DE optimized parallel 2-DOF PID controller for load frequency control of power system with governor dead-band nonlinearity." International Journal of Electrical Power & Energy Systems 49 (2013): 19-33.
- [8] Hamza, Ahmad M., et al. "Design of LFC and AVR for single area power system with PID controller tuning by BFO and Ziegler methods." International Journal of Computer Science and Telecommunications 4.5 (2013): 12-17.
- [9] Taher, Seyed Abbas, Masoud Hajiakbari Fini, and Saber Falahati Aliabadi. "Fractional order PID controller design for LFC in electric power systems using imperialist competitive algorithm." Ain Shams Engineering Journal 5.1 (2014): 121-135.
- [10] Dash, Puja, Lalit Chandra Saikia, and Nidul Sinha. "AGC of a multi-area interconnected system with FACTS and firefly optimized 2DOF PID controller." Control, Instrumentation, Energy and Communication (CIEC), 2014 International Conference on. IEEE, 2014.
- [11] Sahu, Rabindra Kumar, et al. "Teaching learning based optimization algorithm for automatic generation control of power system using 2-DOF PID controller." International Journal of Electrical Power & Energy Systems 77 (2016): 287-301.
- [12] Debnath, Manoj Kumar, Sabita Tripathy, and Ranjan Kumar Mallick. "Hybrid DE-PSO optimized fuzzy-PID controller for Automatic Generation Control of a two area multi-unit power system." Electrical, Computer and Electronics Engineering (UPCON), 2016 IEEE Uttar Pradesh Section International Conference on. IEEE, 2016.
- [13] Mallick, Ranjan Kumar, and Narayan Nahak. "Hybrid differential evolution particle swarm optimization (DE-PSO) algorithm for optimization of unified power flow controller parameters." Electrical,

Computer and Electronics Engineering (UPCON), 2016 IEEE Uttar Pradesh Section International Conference on. IEEE, 2016.

- [14] Singh, Sugandh P., et al. "Analytic hierarchy process based automatic generation control of multi-area interconnected power system using Jaya algorithm." *Engineering Applications of Artificial Intelligence* 60 (2017): 35-44.
- [15] Panigrahi, Tapas Kumar, Aurobindo Behera, and Arun Ku Sahoo. "Novel approach to Automatic Generation Control with various Non-linearities using 2-degree-of-freedom PID controller." *Energy Procedia* 138 (2017): 464-469.