

# Iot Based Ware House Fire Safety System Using ARM7

Guggilla Anusha<sup>1\*</sup>, V.R. Seshagiri Rao<sup>2</sup>

<sup>1</sup>PG Student, Dept. Of Electronics And Communication Engineering, Institute Of Aeronautical Engineering, Hyderabad, India.

<sup>2</sup>Professor, Dept. Of Electronics And Communication Engineering, Institute Of Aeronautical Engineering, Hyderabad, India.

\*Corresponding Author E-Mail:Anushaanshu4@Gmail.Com

## Abstract

For the protection and safety of the garment plant staff has becoming a biggest issue now a days. The garment plant employees face a lot of problems and broken out of fireplace one of them for sure. The depositors aren't showing any interest in this sector and importance of this sector is obtaining toneless. In this research a fireplace detection system is propounded and conjointly provides information of the region affected. Here we used ARM7 which are embedded with different types of sensors. We provide associate authentication system to avoid warning. The system can instantly send a SMS to the admin. The admin will make sure or deny the information. If the admin make sure breaking out of fire then system can right away raise an alarm and a SMS will be sent to the nearby fire brigade.

**Keywords:** Fire safety, ARM7, ESP8266, sensors, authentication, GSM.

## 1. Introduction

The IOT is becoming very popular technology in both work place and outdoors of this we live and also how we have a tendency to work. In this concept any device will be connected with IOT and connect them to the internet. This includes devices like cell phones, laundry machines, earphones, coffee makers, sensors, actuators to the net and they are showing intelligence coupled to alter advanced types of communication among individuals and themselves nearly something. A survey is conducted by Gartner and explains that by 2020 over 26 billion to 64 billion devices will be connected.

The IOT is a large network in which things are connected and is related with people-people, people-things, and things-things. In last two years IOT [2] has vast advancement, this created a new increase in technology and communication. This increase and advancement technology of IOT is resulting to anyone, anything, anytime, anywhere things of property dynamic network of IOT [7] [10]. This technology ideas widely used for the development of space of sensible homes system so as to supply comfort, safety intellect and improved quality of living.

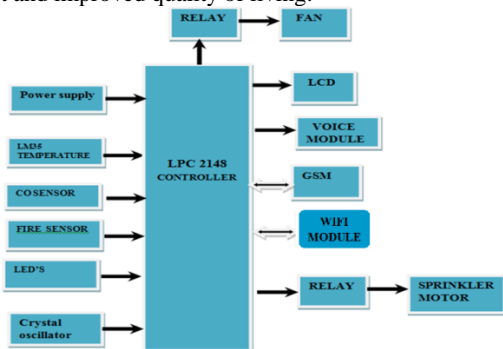

Figure 1.1: Block diagram

## 2. Literature Survey

This system is intended for fire detection in vehicle unclear logic. In this sensor like LM 35, fire and CO sensors square measure are used for sensing fire. This method will detect fire within 20 seconds and ac system is employed for blowout of fireside. The author [4] proposed a system for sensing and detecting forest fire with the help of wireless sensor network. The author implemented how to work on the data collected by sensors rather than sensing the fire. For processing and making the network energy efficient for collected data they used a neural network. Based on the video processing a fire forbidding system was propounded [5]. Spreading characteristics of smoke color square measure accustomed to detect fire outbreak. For processing image it needs highly developed resources because it is time consuming. When it comes to garment plant the fireplace ought to be detected as presently as attainable because garments are sensible to fire. A system [6] was designed for controlling and monitoring by using various sensors like CO, and temperature for sensing fire and starting fire extinguishing process.

## 3. Existing System

In this existing system, replacement is required for several reasons, such as; failure rates of system requirements, failure to meet owner needs, failure to provide replaced parts and lack of knowledge on this fire alarm system. In the previous system wherever the fire was detected it would make only the sprinkler motor and fan ON and also the message is distributed to the admin. There is a security issue that if the admin is not present nearby, then the fire accident would happen. To overcome these security issues, the data is stored in the web server in which the admin will monitor from anyplace in the world.

## 4. Proposed System

This system is capable to find fireplace. And we additionally provided false fireplace suspecting system to avoid any warning. Here we use ARM7 to control [12]. Multiple sensors like fire, temperature, and co sensor are used which are connected to ARM7. Whenever fireplace is detected the system will right away send a message to the admin. If the admin make sure breaking out of fire then system can right away raise an alarm and a SMS will be sent to the nearby fire brigade. The sensor information will be updated in the web page. The info are going to be updated from the enforced system are often accessible in the internet from anywhere within the world. If any sensors get abnormal conditions then voice modular will be on. The sensors knowledge are going to be unendingly observance on LCD [11].

## 5. Methodology

### Fire Sensors

Fire sensor is a simple and compact device that is used for sensing and protecting against hearth. It uses IR sensor and comparator to sense fire up to 1-2 meters of ranging depending on fire density. It consists of 3pins ground, vcc, and out. It consists of led which is used as fire indicator. For adjusting range calibration preset is used.



Fig. 5.1: Fire sensor

### Features

- Allows detecting flames up to 1-2 meter away.
- Fire indicator led is present.
- Operating voltage 4.5v to 6v.
- Input type -digital.
- Output type-digital.
- Operating temperature-0°C to 60°C.

### Temperature Sensor (LM35)

It is an associate IC sensor that is employed to temperature with an associated output voltage linearly proportional to the centigrade temperature. It's a plus over linear temperature sensor. It directly gives the temperature in degree centigrade. There is no need of conversion from Kelvin scale to centigrade. Thus it's appropriate for remote applications and it is higher than thermistor efficiency. In this third pin is connected to gnd, the primary pin is connected to vcc and the second pin is connected to the microcontroller input. Once the temperature is sensing the readings are given to the controller.

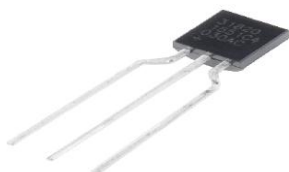

Fig. 5.2: Temperature sensor

### CO Sensor

The MQ2 flammable gas and smoke sensing element detects the concentrations of gas. It detects the carbon monoxide gas presence. It is measured in parts per million (ppm). Its operating range is 0-20000 ppm. It consumes low power. It has small form factor. It has long life and it is stable. It is available in high volume. The drive circuit is extremely simple. It has wide detecting scope.



Fig. 5.3: CO sensor

### Wifi Module [ESP8266]

It is a occasional price WIFI microchip. It follows TCP/IP stack. The capability of microcontroller is created by shanghai based Chinese manufacturers ESPRESSIF systems. It is terribly low price and it has terribly external parts on the module. It might terribly cheap in volume several hackers square measure drawn to explore the module, chip and software on it.



Fig. 5.4: Wi-Fi module

### Voice Module

In this switching is done between traditional broadcasting and voice alarm broadcasting. The control status indicators, output circuits and power provide is checked by this module. When auto feedback is set then the module will transmit feedback signal mechanically to the panel when it switches to fireplace alarm broadcasting. Voice modules are used in fire alarm systems to provide pre-recorded and manual voice messages. Voice modules are the unit systems that gives response personnel with the power to conduct orderly evacuation and apprise the persons present in that place. It will occupy one address. It will be changed through a handheld engineer or fireplace alarm control panel(FACP). It is loop powered mode. It is plug in structure. When the output circuit is brief then it will report fault message to manage panel once it is watching output circuit is brief then it will report fault message to the panel once it is watching output circuit in power on state [13].



Fig. 5.5: Voice module

### FAN

It is an crucial function of fireplace detection and alarm. There are different arrangements for interfacing. The shutdown ventilation fans in the event of a fire system can be configured. Smoke can be controlled depending up on the area of the building. These smoke control systems include fire detection and alarm system.

