

Remote Monitoring and Control of Electrical Appliances in Home for Economic Power Management by Using GSM & Android Application

M. Veerasundaram^{1*}, M. Duraimurugan², S. Karthickraj³, K.M. Sathish⁴, R. Srivenkatesh⁵

¹Department Of EEE, Sri Sairam Institute Of Technology, Chennai.

²Department Of EEE, Sri Sairam Institute Of Technology, Chennai.

³Department Of EEE, Sri Sairam Institute Of Technology, Chennai.

⁴Department Of EEE, Sri Sairam Institute Of Technology, Chennai.

⁵Department Of EEE, Sri Sairam Institute Of Technology, Chennai.

Abstract

The main objective of this paper is to monitor and control all the household electrical appliances with the help of GSM and android application. The system continually monitors voltage and current and calculate the power consumed for every 24 hours and also calculates the cost of the energy consumed by the load. The proposed system is low of cost, flexible in operation and provides benefits for both ends.

Keywords: Power management, wireless sensor network, signal conditioning, home automation, GSM, android application.

1. Introduction

It is known that the electricity is integral part of our life. So it is mandatory that the electricity produced must be utilized in a sensible manner. With the development of technologies monitoring and controlling of electrical appliances became very much important in our day today life. Wireless sensor network (WSN) is made of a large amount of miniature self-organizing wireless sensor nodes [1].By using three kinds of technology such as sensor, micro-mechatronics and wireless communication. It can deal, collect and detect the object information from its covering area and send it to the observer. This has the advantages of covering wide area, high monitoring condition, quick network establishment, remote monitoring and reasonable cost. GSM stands for Global System for Mobile Communication, developed by European telecommunications Standards Institute to give details about the protocols for the second generation digital cellular networks used by mobile devices. It is a mobile communication modem. GSM system was developed as a digital system using time division multiple access (TDMA) technique for communication purpose. It is a open source software.GSM (Global System for Mobile) network has the advantages of wide covering area, longer communication distance and sound communication effect and so on[2].The unit consumed and their respective cost is sent to consumer at remote location through GSM and ON & OFF of electrical appliances can be done from mobile app based on requirements.

2. Circuit Configuration

The existing system uses Zigbee network[11][12]. The proposed system is shown in fig 1.It consist of a PIC microcontroller,

Signal Conditioner, LDR detector, Short circuit detector, GSM and android application. From the network, AC supply is being converted to DC d by signal conditioning and then it is fed to PIC microcontroller.

According to the requirement, the program is being fed to the microcontroller. The LDR sensor[3][4] is used to recognize the light intensity and it is given as input to microcontroller. The short circuit detector detects the any short circuits in the system. The output of the PIC microcontroller is given to GSM, where the data is sent serially and transfer to the phone, where the android application is installed. Through which data is monitored and also controlled automatically for light and manually for other electrical appliances[7][8].Based on command given by the user, the power supply to the load is cutoff by the relay driver[6].The output of relay driver is given to the relay circuit and based on the driver output the relay will cutoff the supply of the load.

3. Circuit Operation Principle

In this paper, the existing technology is modified by the GSM[2].This paper deals with the monitoring and controlling of electrical appliances by using various components.

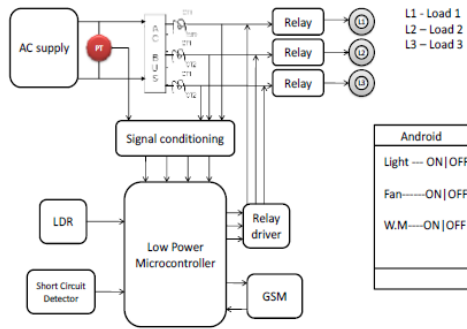

Fig. 1: Proposed block diagram

In the proposed method, potential transformer and current transformer is used to measure the voltage and current respectively. In the transformer, the supply voltage is step down to 6V.

Signal conditioner

The signal conditioner circuit is shown in fig 2. Signal conditioning can include amplification, filtering, converting, range matching, isolation and any other processes required to make sensor output suitable for processing after conditioning.

In other words signal conditioning means manipulating an analog signal in such a way that it meets the requirements of the next stage for further processing. Most common use is in analog-to-digital converters. In this paper, the reduced voltage is given to potential divider and then this voltage is again reduced to 1V. Then it is fed to inverting amplifier, where the negative pulse is converted to positive one. These pulses will be passed to the precision amplifier. In this amplifier required DC pulses will be obtained. The filter circuit is used in order to reduce the unwanted ripples. The zener diode is connected to ensure that the particular range of voltage is given to microcontroller. The voltage above the particular range will be eliminated since input voltage to the microcontroller.

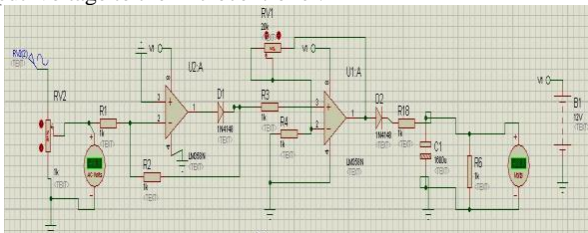

Fig. 2: Signal conditioner

Light dependent resistor (LDR)

An LDR is a component which has a resistance that changes according to the light intensity that falls upon it. This feature allows them to be used in light sensing circuits. In this paper, the LDR[3][5] is used in order to optimize the power consumption. Depending on the brightness level, LDR decides whether the lamp present in that particular room needs to be in ON or in OFF state. If the level of brightness is very high, then resistance of the LDR decreases dramatically and the conduction of electrons takes place resulting in passing of voltage to the micro controller and hence that particular pin of micro controller becomes high. Now the micro controller sends a signal to the Android application stating that the level of brightness is high and the lamp can be in OFF state. LDR characteristics are shown in fig 3.

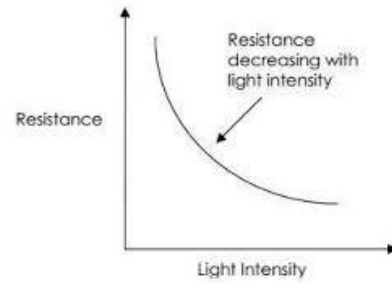

Fig. 3: LDR characteristics

PIC controller

PIC (Peripheral Interface Controller) 16F877 is one of the micro controller. This controller is widely used for experimental applications because of its low price, high quality, and ease of availability. The micro controller is programmed with the input and output port. The micro controller gets the signals from the LDR, signal conditioner and short circuit detector. Through the output port, the cost of energy consumed is transmitted to the android application via GSM. PIC micro controller is shown in fig 4.



Fig. 4: PIC micro controller

GSM 800

A GSM/GPRS module assembles a GSM/GPRS modem with standard communication interfaces like RS-232 (Serial Port), USB etc.[2], so that it can be easily interfaced with a computer or a microprocessor/microcontroller based system. The power supply circuit, activated by using a suitable adaptor and is also built in module. Designed for global market, SIM800 is a quad-band GSM/GPRS module that works on frequencies GSM 850MHz; EGSM 900MHz, DCS 1800MHz and PCS 1900MHz.

Though the Sim900 fulfills all the requirements in advance but for this paper SIM800 is more likely to serve our requirements at low-cost as it can meet almost all the space requirements in users applications such as machine-machine, smart phone, PDA and other mobile devices. GSM module is shown in fig 5.

The salient features of GSM 800:

- Coding schemes: CS-1, CS-2, CS-3, CS-4 TX power: Class 4 (2W), Class 1 (1W)
- Small package: 23 * 23 * 3mm
- Low power: down to 1mA in sleep mode
- TCP/IP AT firmware
- Operating temperature: -40C to +85C
- Audio channels which include a microphone input and a receiver output.
- One SIM card interface.



Fig. 5: GSM 800

Short circuit detector detects the short circuit fault in the lines. In this paper, if any short circuit occurs in the source to load at that instant it detects the short circuit and send command to the micro controller. In this paper the controlling of electrical appliances is done by android application. In which the user can acknowledge the information of electrical appliances from anywhere via GSM and also about the status of the electrical appliances.

Power management android app

The android application is developed by the JAVA language for back end programming and .xml for front end.

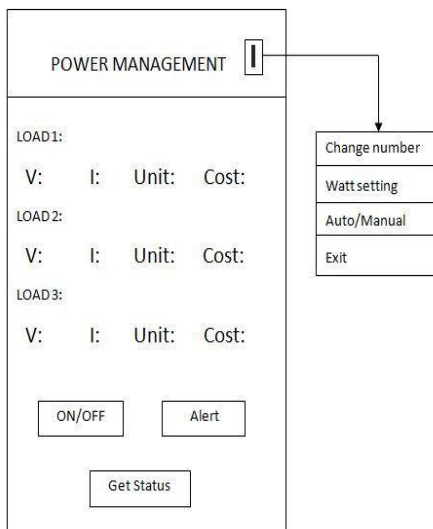

Fig. 6: Android App in mobile screen

The android application is shown in fig 6. In this application energy command, by displays the voltage, current, unit and cost of the electrical appliances. In the top right corner of the application, it has the options to modify the settings of the application like change number, watt setting, auto/manual and exit. The change number is used to change the number of sim, which is in GSM. The watt setting is used to set threshold watt. If appliances reaches this threshold value, it send notification to the application . The mode selection is used to select the mode of appliances like light. Based on the mode selection, the LDR sense the room light and glows the lamp based on that. Additionally, it has ON/OFF button which is used to on and off the load manually. The alert option displays notification about the status of appliances. Finally get status option is used to get the status of appliances, whether the loads are on or off. This application is developed in apk file and this can shared to other mobiles. The command is sent by the user through android application. This command is received by GSM and it will send to relay. The relay circuit is shown in fig 7.

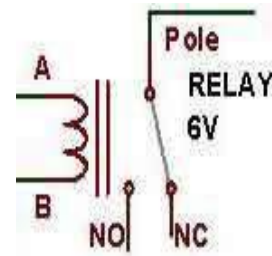

Fig. 7: Relay circuit

4. Relay Circuit

A relay is an electrically operated switch. The magnetic field is created by the relay coil when the current flow through it which attracts a lever and changes in the switch contacts occur. The relays have two switch positions in order to on or off the coil current and they are double throw (changeover) switches. The switch connection of relay are usually named as COM/POLE, NC and NO, COM/POLE= Common, NC= Normally Closed and NO= Normally Open always connect to this, it is the moving part of the switch. NC, COM/POLE is connected to this when the relay coil is not magnetized. When the relay coil is magnetized and vice versa NO, COM/POLE is connected to the relay .Two pins A and B are two ends of a coil that are kept inside the relay. The coil is wound on a small rod that gets magnetized whenever current passes through it. COM/POLE is always connected to NC pin. The pole gets connected to NO pin of the relay as the current is passed through the coil A, B. Relay driver is an electromagnetic switch that is used when we want to use a low voltage circuit to switch on or off the light bulb. Here the required current is supplied by the microcontroller. When the microcontroller receives a signal from the user to turn on the electrical appliance, the corresponding pin in microcontroller goes high and a small current flows through the base of the transistor. This small current gets amplified while it passes through the collector terminal of the transistor[6]. This energizes the relay which attracts the switch and the appliance turns on. Similarly, when appliance is required to be turned off the relay gets de-energize the switch gets released and the appliance is turned off. The developed product implemented in real-time electrical appliances is shown in fig 8.



Fig. 8: Developed system with different electrical appliance

5. Design and Simulation

The simulated circuit depicts the different loads consumption and their cost with respect to time and also defines status of the

electrical appliances (ON/OFF). The simulated circuit diagram is shown in fig 9.

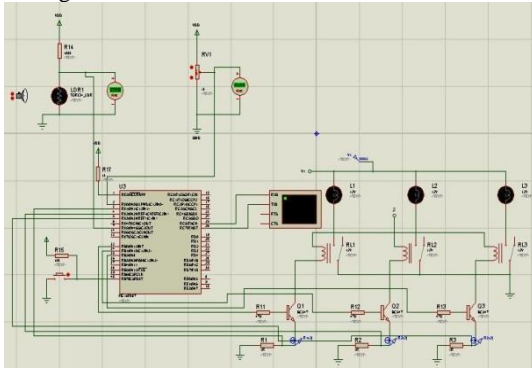

Fig. 9: Simulated circuit diagram

The main aim of the system is to measure the power consumed by the consumer. For this we have to measure the voltage and current consumed by each electrical appliances. For this purpose the voltage and the current transformers are used. In case of voltage transformer the voltage that is being measured from the supply will be stepped down to 1V by making use of the step down transformer and voltage divider rule. Then this voltage signal will be signal conditioned by passing it through the inverting and non-inverting amplifier. At first the AC supply will be applied to an amplifier where it is converted to uni-directional voltage and for precision control it is sent through the another amplifier. The final signal is given as a input to the microcontroller. Between these two amplifiers there is a diode which makes sure the signals between the inverting and non-inverting amplifier doesn't mix with each other. Finally there is a zener diode to make sure the voltage given to microcontroller doesn't exceed a particular value.

In the case of measurement of current the current transformer is used and the voltage drop is measured. Similar to the measurement of voltage this voltage drop measured is sent for signal conditioning through amplifiers and output of the amplifiers is given as a input to the microcontroller. The LDR is used in order to measure the amount of brightness present in the room. If LDR senses an excessive amount of brightness it directs the microcontroller to turn off the light.

There are two different modes of operation auto and manual .In the auto mode the control operations are automatically controlled by the microcontroller without any manual intervention. In the case of manual mode the user decides the status of each load (i.e) either in ON or OFF state. It can be controlled from android application developed. When the user makes a appliance ON in the application, the microcontroller receives the signal through GSM.

This signal activates the BJT which in turn makes the relay driver go be activated. When relay driver is activated the relay will be pulled and the appliance will be in ON state and vice versa to make the appliance OFF. The measured power will be sent to the android application through the GSM facility.

In the simulation, Virtual terminal acts as android application in which the amount of power consumed and the respective cost will be displayed .

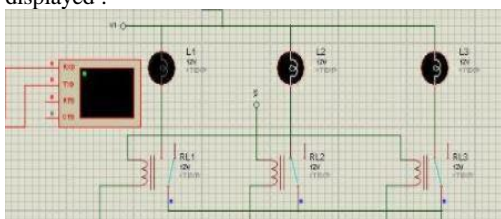

Fig. 10: Light glows

By the help of android application, the current status of appliance whether it is on or in off state will be known in which user will automatically control it from anywhere in the

locality.The result of simulation is shown in the fig.10 and fig.11.



Fig. 11: Simulation result

In the above fig, the mode is in manual mode and the consumer decides the lamp A to be in OFF state and the other two are in ON state. Since the LDR status is in low state the microcontroller allows the relay to switch ON the lights. Now the amount of current and voltage consumed by the appliance is shown in the virtual terminal.

6. Conclusion

Awareness of electricity consumption in the home or building is a first step towards saving energy. This system presents a smart energy management system for homes and buildings. The proposed system can monitor and measure electricity usage in real-time and it also serve benefits for both the providers and the users. With the proposed system, users can remotely control real-time electrical appliances through mobile device. Thereby controlling the consumption of electricity by user,will pave way for saving it for the future generation. Since every sources in the earth should be used in an appropriate manner to our requirements only not to make it to become an extinct one.

7. Future Scope

The main scope of this paper is to make sure that the people know how much energy is being consumed by them every day and thereby can reduce the unnecessary energy used by them. In future, the cost of the energy can be reduced due to advancement in technology. When cost is reduced significantly it can also be used in industries where the wastage of power is maximum. The time duration for which each appliance is operated can also be added and hence each appliance can be protected from over usage. Since the power consumption is reduced, both the consumer and the producer will be benefitted by application of this technology. In future, each device can be programmed in such a manner that if the power consumption exceeds a certain amount then power supply can be stopped to that appliance until the bill has been paid.

References

[1] Suryadevara NK, Mukhopadhyay SC, Kelly SDT & Gill SPS, "WSN-Based power sensor and actuators for power

- management in intelligent buildings”, *IEEE/ASME Transactions on Mechatronics*, Vol.20, No.2, (2017).
- [2] Huang H, Xiao S, Meng X & Xiong Y, “A Remote Home Security System Based on Wireless Sensor Network and GSM Technology”, *Second International Conference on Networks Security, Wireless Communications and Trusted Computing*, (2010).
- [3] Pan MS, Yeh LW, Chen YA, Lin YH & Tseng YC, “A WSNbased intelligent light control system considering user activities and profiles”, *IEEE Sensors J.*, Vol.8, No.10, (2008), pp.1710–1721.
- [4] Cheong P, Chang KF, Lai YH, Ho SK, Sou IK & Tam KW, “A zigbee-based wireless sensor network node for ultraviolet detection of flame”, *IEEE Trans. Ind. Electron.*, Vol.58, No.11, (2011), pp.5271–5277.
- [5] Suh C & Ko YB, “Design and implementation of intelligent home control systems based on active sensor networks”, *IEEE Trans. Consumer Electron.*, Vol.54, No.3, (2008), pp.1177–1184
- [6] Triacs-BT 138 Series, Philips Semiconductors (accessed on 8 Jan.2012).
<http://docs-asia.electrocomponents.com/webdocs/0b4b/0900766b80b4bf38.pdf>
- [7] Andrey E & Morelli J, “Design of a smart meter techno-economic model for electric utilities in Ontario”, *Proc. IEEE-Electric Power Energy Conf.*, (2010), pp. 1–7.
- [8] Ghataoura DS, Mitchell JE & Matich GE, “Networking and application interface technology for wireless sensor network surveillance and monitoring”, *IEEE Commun.Mag.*, Vol.49, No.10, (2011), pp.90–97.
- [9] Li L, Xiaoguang H, Jian H & Ketai H, “Design of new architecture of AMR system in Smart Grid”, *Proc. 6th IEEE Conf. Ind. Electron. Appl.*, (2011), pp. 2025–2029.
- [10] Erol-Kantarci M & Moutfah HT, “Wireless sensor networks for costefficient residential energy management in the smart grid”, *IEEE Trans. Smart Grid*, Vol.2, No.2, (2011), pp.314–325.
- [11] Man Han D & Hyun Lim J, “Smart home energy management system using IEEE 802.15.4 and zigbee”, *IEEE Trans. ConsumerElectron.*, Vol.56, No.3, (2010), pp.1403–1410.
- [12] Kamat VN, “Enabling an electrical revolution using smart apparent energy meters & tariffs”, *Proc. Annu. IEEE India Conf.*, (2011), pp. 1–4.
- [13] Han J, Choi CS & Lee I, “More efficient home energy management system based on zigbee communication and infrared remote controls”, *IEEE Trans. Consumer Electron.*, Vol.57, No.1, (2011), pp. 85–89.
- [14] The costs and benefits of smart meters for residential customers, (2012).
- [15] ZigBee alliance examining Japan’s new smart home recommendations (2012).