



A New Four-Scroll Chaotic System with a Self-Excited Attractor and Circuit Implementation

Sivaperumal Sampath¹, Sundarapandian Vaidyanathan², Aceng Sambas^{3*}, Mohamad Afendee Mohamed⁴, Mustafa Mamat⁴ and W. S. Mada Sanjaya⁵

¹Department of Electronics and Communication Engineering, Vel Tech University, Avadi, Chennai, India

²Research and Development Centre, Vel Tech University, Avadi, Chennai, India

³Department of Mechanical Engineering, Universitas Muhammadiyah Tasikmalaya, Indonesia

⁴Faculty of Informatics and Computing, Universiti Sultan Zainal Abidin, Malaysia

⁵Department of Physics, Universitas Islam Negeri Sunan Gunung Djati Bandung, Indonesia

*acengs@umtas.ac.id

Abstract

This paper reports the finding a new four-scroll chaotic system with four nonlinearities. The proposed system is a new addition to existing multi-scroll chaotic systems in the literature. Lyapunov exponents of the new chaotic system are studied for verifying chaos properties and phase portraits of the new system via MATLAB are unveiled. As the new four-scroll chaotic system is shown to have three unstable equilibrium points, it has a self-excited chaotic attractor. An electronic circuit simulation of the new four-scroll chaotic system is shown using MultiSIM to check the feasibility of the four-scroll chaotic model.

Keywords: Chaos, chaotic systems, circuit simulation, four-scroll system, Lyapunov exponents

1. Introduction

Chaos theory has applications in several branches of science and engineering. Some of the popular applications can be listed as oscillators ([1]-[6]), population ecology ([9]-[11]), epilepsy [12], neurons ([13]-[16]), random bit generators [17], neural networks ([18]-[20]), text encryption [21], image encryption ([22]-[24]), voice encryption [25], economy ([26]-[27]), weather systems ([28]-[30]), chemical reactions ([31]-[34]), robotics ([35]-[38]), and secure communication systems ([40]-[42]).

The development of multi-scroll chaotic attractors is an active research topic. Some classical examples of two-scroll chaotic attractors can be cited as Lorenz system [43], Lü system [44] and Tigan system [45]. Some recent examples of two-scroll chaotic attractors can be mentioned as Lien system [46], Vaidyanathan systems ([47]-[49]), Zheng system [50], etc. Some newly discovered examples of three-scroll chaotic attractors can be described as Dadras system [51], Pan system [52], Vaidyanathan 3-scroll system [53], etc. Many four-scroll attractors have been also reported in the literature such as Wang system [54], Lü 4-scroll system [55], Liu-Chen 4-scroll system [56], Sampath 4-scroll system [57], Akgul system [58], etc. In 2003, Yang and Li showed how to generate n -scroll chaotic system with the help of scalar output feedback control [59].

In this paper, we report the finding of a new four-scroll chaotic system with four nonlinear terms. We show that the system has dissipative and self-excited attractor with three equilibrium points. Furthermore, using MultiSIM, we design the electronic circuit of the new four-scroll chaotic system and verify the feasibility of

the new chaotic oscillator.

Circuit design of chaotic systems is important for their practical implementation. Many papers in the chaos literature have studied on the electronic circuit implementation of chaotic systems and the chaotic circuits are useful in many control applications ([60]-[69]).

2. A new four-scroll chaotic system with self-excited attractor

We report a new three-dimensional dynamical system given by

$$\begin{cases} \dot{x} &= a(y-x) + byz \\ \dot{y} &= -y - 10y|y| + 4xz \\ \dot{z} &= cz - xy \end{cases} \quad (1)$$

which has a total of four nonlinear terms in the dynamics.

We show that the system (1) is *chaotic* for the parameter values $(a, b, c) = (3, 12, 4)$.

For numerical simulations of phase portraits and for the calculation of Lyapunov chaos exponents, we take the initial values as $X(0) = (0.1, 0.1, 0.1)$ and parameter set as $(a, b, c) = (3, 12, 4)$.

The Lyapunov chaos exponents are determined as $(L_1, L_2, L_3) = (0.6022, 0, -15.0407)$ using Wolf's algorithm [70]. Since $L_1 > 0$, the new system (1) is chaotic. By adding L_1, L_2 and L_3 , we get the sum as -14.4385 , which is negative. This shows that the new system (1) is dissipative. The Kaplan-Yorke dimension is determined as

$$D_{KY} = 2 + (L_1 + L_2)/|L_3| = 2.0400 \quad (2)$$

which gives a pointer to the complexity of the four-scroll chaotic system (1).

We note that the four-scroll chaotic system (1) is invariant for all parameter values under the coordinates transformation $(x, y, z) \mapsto (-x, -y, z)$. This pinpoints that the four-scroll chaotic system (1) has *rotation symmetry* about the z -axis. Hence, every non-trivial system trajectory of the four-scroll model (1) has a twin trajectory of the four-scroll model (1).

The equilibrium points of the new system (1) are tracked by solving the following system:

$$\begin{cases} a(y-x) + byz & = 0 \\ -y - 10y|y| + 4xz & = 0 \\ cz - xy & = 0 \end{cases} \quad (3)$$

For the parameter values $(a, b, c) = (3, 12, 4)$, the system (3) has three equilibrium points given by

$$Q_0 = \begin{bmatrix} 0 \\ 0 \\ 0 \end{bmatrix}, \quad Q_1 = \begin{bmatrix} 3.0837 \\ 0.8509 \\ 0.6560 \end{bmatrix}, \quad Q_2 = \begin{bmatrix} -3.0837 \\ -0.8509 \\ 0.6560 \end{bmatrix} \quad (4)$$

A simple calculation using the Jacobian matrix of the system (1) shows that the equilibrium point Q_0 is a saddle point, while the equilibrium points Q_1 and Q_2 are saddle-foci equilibrium points. Thus, all three rest points Q_0, Q_1, Q_2 are unstable. This shows that the new four-scroll system (1) has a self-excited attractor.

The phase portraits of the new chaotic system (1) with four-scroll phase portraits are displayed in Figures 1-4.

The Lyapunov chaos exponents of the new chaotic system (1) are displayed in Figure 5.

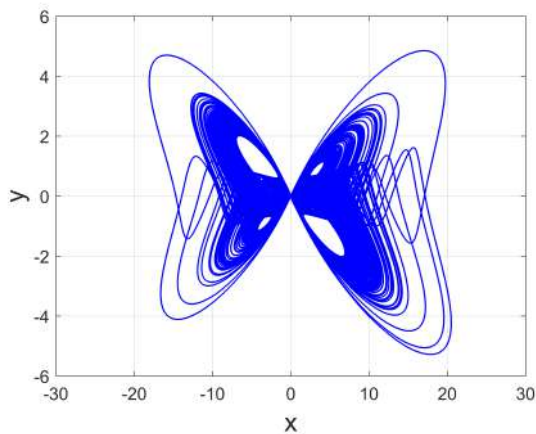

Figure 1: MATLAB simulations of phase portraits of the new four-scroll system (1) for $X(0) = (0.1, 0.1, 0.1)$ and $(a, b, c) = (3, 12, 4)$ in $x-y$ plane

3. Circuit Simulation

In the process of scaling, we proposed $(X, Y, Z) = (x/5, y, z)$ and then the scaled system is obtained as:

$$\begin{cases} \dot{x} & = a(\frac{y}{5} - x) + \frac{b}{5}yz \\ \dot{y} & = -y - 10y|y| + 20xz \\ \dot{z} & = cz - 5xy \end{cases} \quad (5)$$

Based on Kirchhoff's law, the corresponding circuit equations can

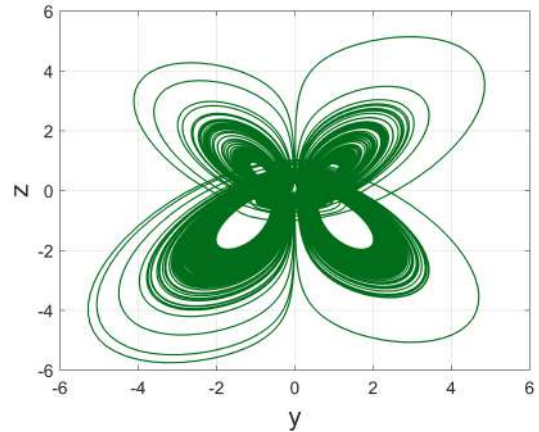

Figure 2: MATLAB simulations of phase portraits of the new four-scroll system (1) for $X(0) = (0.1, 0.1, 0.1)$ and $(a, b, c) = (3, 12, 4)$ in $y-z$ plane

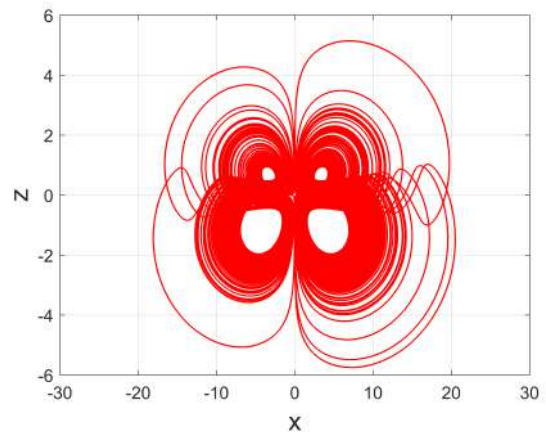

Figure 3: MATLAB simulations of phase portraits of the new four-scroll system (1) for $X(0) = (0.1, 0.1, 0.1)$ and $(a, b, c) = (3, 12, 4)$ in $x-z$ plane

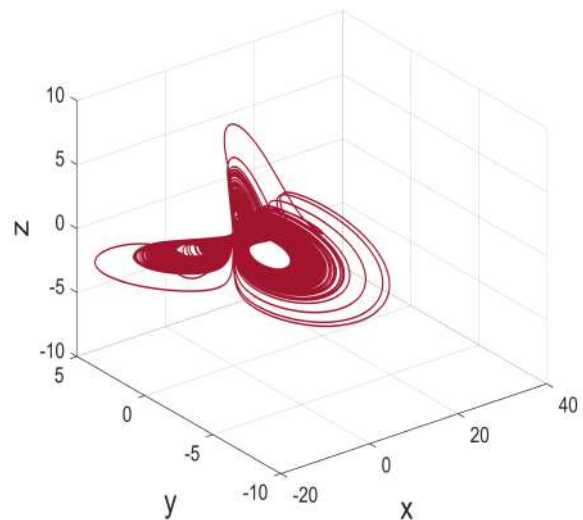

Figure 4: MATLAB simulations of phase portraits of the new four-scroll system (1) for $X(0) = (0.1, 0.1, 0.1)$ and $(a, b, c) = (3, 12, 4)$ in R^3

be expressed as

$$\begin{cases} \dot{x} & = \frac{1}{C_1R_1}y - \frac{1}{C_1R_2}x + \frac{1}{10C_1R_3}yz \\ \dot{y} & = -\frac{1}{C_2R_4}y - \frac{1}{10C_2R_5}y|y| + \frac{1}{10C_2R_6}xz \\ \dot{z} & = \frac{1}{C_3R_7}z - \frac{1}{10C_3R_8}xy \end{cases} \quad (6)$$

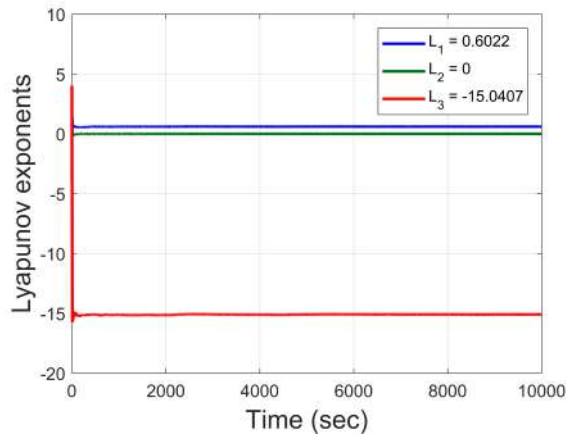

Figure 5: Lyapunov chaos exponents of the new four-scroll system (1) for $X(0) = (0.1, 0.1, 0.1)$ and $(a, b, c) = (3, 12, 4)$

where x , y , and z are the voltages on capacitors C_1 , C_2 and C_3 , respectively. While the power supply is ± 15 V. The circuit diagram of new four scroll system (6) raised by the MultiSIM software is presented in Fig. 6. The values of circuit components are $R_1 = 666.67$ k Ω , $R_2 = 133.33$ k Ω , $R_3 = 16.67$ k Ω , $R_4 = 400$ k Ω , $R_5 = 4$ k Ω , $R_6 = 2$ k Ω , $R_8 = 8$ k Ω , $R_7 = R_9 = R_{10} = R_{11} = R_{12} = R_{13} = R_{14} = R_{15} = R_{16} = R_{17} = R_{18} = R_{19} = 100$ k Ω and $C_1 = C_2 = C_3 = 2.2$ nF. Obtained MultiSIM results in Fig. 7 indicate that the circuit exhibits chaotic attractors. The oscilloscope results in Fig. 7 show good consistency with the MATLAB simulations in Fig. (1-3).

4. Conclusion

In this research paper, we found a new four-scroll system with a self-excited attractor. The proposed system is a new addition to existing chaotic systems with multi-scroll attractors in the literature. Lyapunov exponents of the new chaotic system were investigated for verifying chaos properties and phase portraits of the new system via MATLAB are unveiled. An electronic circuit simulation of the new chaotic system with four scroll attractors was carried out using MultiSIM to check the model feasibility. As future research work, application of the new chaotic system for voice or image encryption and secure communication systems can be investigated.

Acknowledgement

This project is partially funded by the Research Management, Innovation and Commercialization Center, Universiti Sultan Zainal Abidin.

References

- [1] E.H. Hellen and E. Volkov, "How to couple identical ring oscillators to get quasiperiodicity, extended chaos, multistability, and the loss of symmetry", *Communications in Nonlinear Science and Numerical Simulation*, Vol. 62, (2018), pp. 462–479.
- [2] L. Wang and X.S. Yang, "Global analysis of a generalized Nose-Hoover oscillator", *Journal of Mathematical Analysis and Applications*, Vol. 464, No. 1, (2018), pp. 370–379.
- [3] S. Vaidyanathan and S. Rasappan, "Hybrid synchronization of hyperchaotic Qi and Lü systems by nonlinear control", *Communications in Computer and Information Science*, Vol. 131, (2011), pp. 585–593.
- [4] V.T. Pham, C.K. Volos and S. Vaidyanathan, "Multi-scroll chaotic oscillator based on a first-order delay differential equation", *Studies in Computational Intelligence*, Vol. 581, (2015), pp. 59–72.
- [5] S. Vaidyanathan, C.K. Volos and V.T. Pham, "Global chaos control of a novel nine-term chaotic system via sliding mode control", *Studies in Computational Intelligence*, Vol. 576, (2015), pp. 571–590.
- [6] D. Ghosh, A. Mukherjee, N.R. Das and B.N. Biswas, "Generation & control of chaos in a single loop optoelectronic oscillator", *Optik*, Vol. 165, (2018), pp. 275–287.
- [7] S. Vaidyanathan, "Output regulation of the forced Van der Pol chaotic oscillator via adaptive control method", *International Journal of PharmTech Research*, Vol. 8, No. 6, (2015), pp. 106–116.
- [8] S. Vaidyanathan, "Global chaos synchronization of the forced Van der Pol chaotic oscillators via adaptive control method", *International Journal of PharmTech Research*, Vol. 8, No. 6, (2015), pp. 156–166.
- [9] O.I. Massoud, J. Huisman, E. Beninca, M.C. Dietze, W. Bouten, and J.A. Vrugt, "Probing the limits of predictability: data assimilation of chaotic dynamics in complex food webs", *Ecology Letters*, Vol. 21, No. 1, (2018), pp. 93–103.
- [10] S. Vaidyanathan, "Lotka-Volterra population biology models with negative feedback and their ecological monitoring", *International Journal of PharmTech Research*, Vol. 8, No. 5, (2015), pp. 974–981.
- [11] J.C. Sprott, J.A. Vano, J.C. Wildenberg, M.B. Anderson, J.K. Noel, "Coexistence and chaos in complex ecologies", *Physics Letters A*, Vol. 335, No. 2–3, (2005), pp. 207–212.
- [12] S. Panahi, Z. Aram, S. Jafari, J. Ma and J.C. Sprott, "Modeling of epilepsy based on chaotic artificial neural network", *Chaos, Solitons and Fractals*, Vol. 105, (2017), pp. 150–156.
- [13] I. Bashkirtseva, V. Nasyrova and L. Ryashko, "Noise-induced bursting and chaos in the two-dimensional Rulkov model", *Chaos, Solitons and Fractals*, Vol. 110, (2018), pp. 76–81.
- [14] J. Guckenheimer and R.A. Oliva, "Chaos in the Hodgkio-Hoxley model", *SIAM Journal on Applied Dynamical Systems*, Vol. 1, No. 1, (2002), pp. 105–114.
- [15] S. Vaidyanathan, "Adaptive control of the FitzHugh-Nagumo chaotic neuron model", *International Journal of PharmTech Research*, Vol. 8, No. 6, (2015), pp. 117–127.
- [16] Y. Yang, X. Liao and T. Dong, "Period-adding bifurcation and chaos in a hybrid Hindmarsh-Rose model", *Neural Networks*, Vol. 105, (2018), pp. 26–35.
- [17] M. Kim, U. Ha, K.J. Lee, Y. Lee, and H.J. Yoo, "A 82-nW Chaotic Map True Random Number Generator Based on a Sub-Ranging SAR ADC", *IEEE Journal of Solid-State Circuits*, Vol. 52, No. 7, (2017), pp. 1953–1965.
- [18] K. Bouallegue, "A new class of neural networks and its applications", *Neurocomputing*, Vol. 249, (2017), pp. 28–47.
- [19] S. Vaidyanathan, "Synchronization of 3-cells cellular neural network (CNN) attractors via adaptive control method", *International Journal of PharmTech Research*, Vol. 8, No. 5, (2015), pp. 946–955.
- [20] M. Sadeghpour, M. Khodabakhsh and H. Salarieh, "Intelligent control of chaos using linear feedback controller and neural network identifier", *Communications in Nonlinear Science and Numerical Simulation*, Vol. 17, No. 12, (2012), pp. 4731–4739.
- [21] Y. Dai, H. Wang, and H. Sun, "Cyclic-shift chaotic medical image encryption algorithm based on plain text key-stream", *International Journal of Simulation: Systems, Science and Technology*, Vol. 17, No. 27, (2016), pp. 24.1-24.8.
- [22] A. Ullah, S. S. Jamal and T. Shah, "A novel scheme for image encryption using substitution box and chaotic system", *Nonlinear Dynamics*, Vol. 91, No. 1, (2018), pp. 359-370.
- [23] N.K. Pareek, V. Patidar and K.K. Sud, "Image encryption using chaotic logistic map", *Image and Vision Computing*, Vol. 24, No. 9, (2006), pp. 926–934.
- [24] A.A. Elsadany, A.M. Yousef and A. Elsonbaty, "Further analytical bifurcation analysis and applications of coupled logistic maps", *Applied Mathematics and Computation*, Vol. 338, (2018), pp. 314–336.
- [25] S. Vaidyanathan, A. Sambas, M. Mamat, and W. S. M. Sanjaya, "Analysis, synchronisation and circuit implementation of a novel jerk chaotic system and its application for voice encryption", *International Journal of Modelling, Identification and Control*, Vol. 28, No. 2, (2017), pp. 153-166.
- [26] O.I. Tacha, Ch. K. Volos, I.M. Kyprianidis, I.N. Stouboulos, S. Vaidyanathan and V. T. Pham, "Analysis, adaptive control and circuit simulation of a novel nonlinear finance system", *Applied Mathematics and Computation*, Vol. 276, (2016), pp. 200–217.
- [27] I. Klioutchnikov, M. Sigova and N. Beizerov, "Chaos theory in Finance", *Procedia Computer Science*, Vol. 119, (2017), pp. 368–375.
- [28] M.O. Fen, "Persistence of chaos in coupled Lorenz systems", *Chaos, Solitons & Fractals*, Vol. 95, (2017), pp. 200–205.
- [29] S. Rasappan and S. Vaidyanathan, "Global chaos synchronization of WINDMI and Couillet chaotic systems by backstepping control", *Far East Journal of Mathematical Sciences*, Vol. 67, No. 2, (2012), pp. 265–287.
- [30] S. Vaidyanathan, C.K. Volos, K. Rajagopal, I.M. Kyprianidis and I.N. Stouboulos, "Adaptive backstepping controller design for the anti-synchronization of identical WINDMI chaotic systems with unknown parameters and its SPICE implementation", *Journal of Engineering Science and Technology Review*, Vol. 8, No. 2, (2015), pp. 74–82.
- [31] S. Vaidyanathan, "Adaptive synchronization of novel 3-D chemical chaotic reactor systems", *International Journal of ChemTech Research*, Vol. 8, No. 7, (2015), pp. 159–171.
- [32] S. Sarwar and S. Iqbal, "Stability analysis, dynamical behavior and analytical solutions of nonlinear fractional differential system arising in chemical reaction", *Chinese Journal of Physics*, Vol. 56, No. 1, (2018), pp. 374–384.
- [33] C. Xu and Y. Wu, "Bifurcation and control of chaos in a chemical system", *Applied Mathematical Modelling*, Vol. 39, No. 8, (2015), pp. 2295–2310.

- [34] I. Dodale and V.A. Oancea, "Chaos control for Willamowski-Rössler model of chemical reactions", *Chaos, Solitons & Fractals*, Vol. 78, (2015), pp. 1–9.
- [35] S. Vaidyanathan, A. Sambas, M. Mamat, and W. S. M. Sanjaya, "A new three-dimensional chaotic system with a hidden attractor, circuit design and application in wireless mobile robot", *Archives of Control Sciences*, Vol. 27, No. 4, (2017), pp. 541–554.
- [36] S. Iqbal, X. Zang, Y. Zhu and J. Zhao, "Bifurcations and chaos in passive dynamic walking: A review", *Robotics and Autonomous Systems*, Vol. 62, No. 6, (2014), pp. 889–909.
- [37] S.M. Jafarov, E.R. Zeynalov and A.M. Mustafayeva, "Synthesis of the optimal fuzzy T-S controller for the mobile robot using the chaos theory", *Procedia Computer Science*, Vol. 102, (2016), pp. 302–308.
- [38] A. Sambas, S. Vaidyanathan, M. Mamat, W. S. M. Sanjaya and D. S. Rahayu, "A 3-D novel jerk chaotic system and its application in secure communication system and mobile robot navigation", *Studies in Computational Intelligence*, Vol. 636, (2016), pp. 283–310.
- [39] C.K. Volos, V.T. Pham, S. Vaidyanathan, I.M. Kyprianidis and I.N. Stouboulos, "Synchronization phenomena in coupled Colpitts circuits", *Journal of Engineering Science and Technology Review*, Vol. 8, No. 2, (2015), pp. 142–151.
- [40] C. Jayawickrama, S. Kumar and H. Song, "Novel wideband chaotic approach LNA with microcontroller compatibility for 5G wireless secure communication", *Microwave and Optical Technology Letters*, Vol. 60, No. 2, (2018), pp. 48–494.
- [41] A. Sambas, W. S. M. Sanjaya, M. Mamat and R. P. Prastio, "Mathematical modelling of chaotic Jerk circuit and its application in secure communication System", *Studies in Fuzziness and Soft Computing*, Vol. 337, (2016), pp. 133–153.
- [42] S. Khorashadizadeh and M.H. Majidi, "Chaos synchronization using the Fourier series expansion with application to secure communications", *AEU-International Journal of Electronics and Communications*, Vol. 82, (2017), pp. 37–44.
- [43] E.N. Lorenz, "Deterministic nonperiodic flow", *Journal of the Atmospheric Sciences*, Vol. 20, (1963), pp. 130–141.
- [44] J. Lü and G. Chen, "A new chaotic attractor coined", *International Journal of Bifurcation and Chaos*, Vol. 9, (1999), pp. 1465–1466.
- [45] G. Tigan and D. Opris, "Analysis of a 3D chaotic system", *Chaos, Solitons and Fractals*, Vol. 36, (2008), pp. 1315–1319.
- [46] C.H. Lien, S. Vaidyanathan, A. Sambas, Sukono, M. Mamat, W.S.M. Sanjaya and Subiyanto, "A new two-scroll chaotic attractor with three quadratic nonlinearities, its adaptive control and circuit design", *IOP Conference Series: Materials Science and Engineering*, Vol. 332, No. 1, (2018), art. no. 012010.
- [47] S. Vaidyanathan, "Global chaos control and synchronization of a novel two-scroll chaotic system with three quadratic nonlinearities", *Studies in Computational Intelligence*, Vol. 636, (2016), pp. 235–255.
- [48] S. Vaidyanathan and K. Rajagopal, "Analysis, control, synchronization and LabVIEW implementation of a seven-term novel chaotic system", *International Journal of Control Theory and Applications*, Vol. 9, No. 1, (2016), pp. 151–174.
- [49] S. Vaidyanathan and A. Boulkroune, "A novel hyperchaotic system with two quadratic nonlinearities, its analysis and synchronization via integral sliding mode control", *International Journal of Control Theory and Applications*, Vol. 9, No. 1, (2016), pp. 321–337.
- [50] P. Zheng, W. Tang and J. Zhang, "Some novel double-scroll chaotic attractors in Hopfield networks", *Neurocomputing*, Vol. 73, Nos. 10–12, (2010), pp. 2280–2285.
- [51] S. Dadras and H.R. Momeni, "Generating one-, two-, three- and four-scroll attractors from a novel four-dimensional smooth autonomous chaotic system", *Chinese Physics B*, Vol. 19, (2009), art. no. 060506.
- [52] L. Pan, W. Zhou, J. Fang and D. Li, "A new three-scroll unified chaotic system coined", *International Journal of Nonlinear Science*, Vol. 10, (2010), pp. 462–474.
- [53] S. Vaidyanathan, "Mathematical analysis, adaptive control and synchronization of a ten-term novel three-scroll chaotic system with four quadratic nonlinearities", *International Journal of Control Theory and Applications*, Vol. 9, No. 1, (2016), pp. 1–20.
- [54] Z. Wang, Y. Sun, B.J. van Wyk, G. Qi and M.A. van Wyk, "A 3-D four-wing attractor and its analysis", *Brazilian Journal of Physics*, Vol. 39, (2009), pp. 547–553.
- [55] J. Lü, G. Chen and D. Cheng, "A new chaotic system and beyond: the generalized Lorenz-like system", *International Journal of Bifurcation and Chaos*, Vol. 14, (2004), pp. 1507–137.
- [56] W. Liu and G. Chen, "Can a three-dimensional smooth autonomous quadratic chaotic system generate a single four-scroll attractor?", *International Journal of Bifurcation and Chaos*, Vol. 14, (2004), pp. 1395–1403.
- [57] S. Sampath, S. Vaidyanathan, C.K. Volos and V.T. Pham, "An eight-term novel four-scroll chaotic system with cubic nonlinearity and its circuit simulation", *Journal of Engineering Science and Technology Review*, Vol. 8, (2015), pp. 1–6.
- [58] A. Akgul, I. Moroz, I. Pehlivan and S. Vaidyanathan, "A new four-scroll chaotic attractor and its engineering applications", *Optik*, Vol. 127, No. 13, (2016), pp. 5491–5499.
- [59] X.S. Yang and Q. Li, "Generate n -scroll attractor in linear system by scalar output feedback", *Chaos, Solitons & Fractals*, Vol. 18, (2003), pp. 25–29.
- [60] F. Yu, P. Li, K. Gu and B. Yin, "Research progress of multi-scroll chaotic oscillators based on current-mode devices", *Optik*, Vol. 13, (2016), pp. 5486–5490.
- [61] L. Chen, "A framework to enhance security of physically unclonable functions using chaotic circuits", *Physics Letters A*, Vol. 382, No. 18, (2018), pp. 1195–1201.
- [62] C. Volos, J.O. Maaïta, S. Vaidyanathan, V.T. Pham, I. Stouboulos and I. Kyprianidis, "A novel four-dimensional hyperchaotic four-wing system with a saddle-focus equilibrium", *IEEE Transactions on Circuits and Systems-II: Express Briefs*, Vol. 64, No. 3, (2017), pp. 339–343.
- [63] V.T. Pham, S. Jafari, C. Volos, A. Giakoumis, S. Vaidyanathan and T. Kapitaniak, "A chaotic system with equilibria located on the rounded square loop and its circuit implementation", *IEEE Transactions on Circuits and Systems-II: Express Briefs*, Vol. 63, No. 9, (2016), pp. 878–882.
- [64] X. Zhang, Z. Li and D. Chang, "Dynamics, circuit implementation and synchronization of a new three-dimensional fractional-order chaotic system", *AEU - International Journal of Electronics and Communications*, Vol. 82, (2017), pp. 435–445.
- [65] S. Behnia, Z. Pazhotan, N. Ezzati and A. Akhshani, "Reconfigurable chaotic logic gates based on novel chaotic circuit", *Chaos, Solitons & Fractals*, Vol. 69, (2014), pp. 74–80.
- [66] A. Sambas, Mujiarto, M. Mamat, and W.S.M. Sanjaya, "Numerical simulation and circuit implementation for a sprout chaotic system with one hyperbolic sinusoidal nonlinearity", *Far East Journal of Mathematical Sciences*, Vol. 102, No. 6, (2017), pp. 1165–1177.
- [67] A. Sambas, S. Vaidyanathan, M. Mamat, W.S.M. Sanjaya and R.P. Prastio, "Design, analysis of the Genesio-Tesi chaotic system and its electronic experimental implementation", *International Journal of Control Theory and Applications*, Vol. 9, No. 1, (2016), pp. 141–149.
- [68] S. Vaidyanathan, A.T. Azar, K. Rajagopal, A. Sambas, S. Kacar and U. Cavusoglu, "A new hyperchaotic temperature fluctuations model, its circuit simulation, FPGA implementation and an application to image encryption", *International Journal of Simulation and Process Modelling*, Vol. 13, No. 3, (2018), pp. 281–296.
- [69] E. Tlelo-Cuautle, J. Rangel-Magdaleno and A. Pano-Azucena, "FPGA realization of multi-scroll chaotic oscillators", *Communications in Nonlinear Science and Numerical Simulation*, Vol. 27, Nos. 1–3, (2015), pp. 66–80.
- [70] A. Wolf, J. B. Swift, H. L. Swinney and J. A. Vastano, "Determining Lyapunov exponents from a time series", *Physica D: Nonlinear Phenomena*, Vol. 16, No. 3, (1985), pp. 285–317.

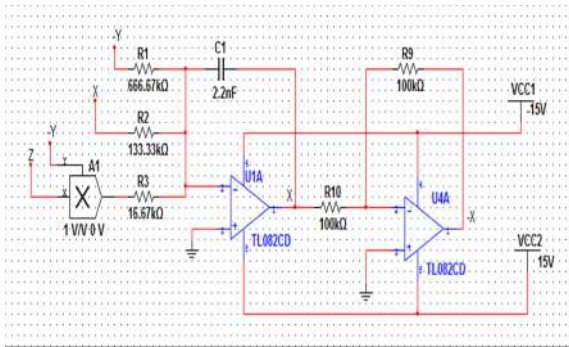

(a)

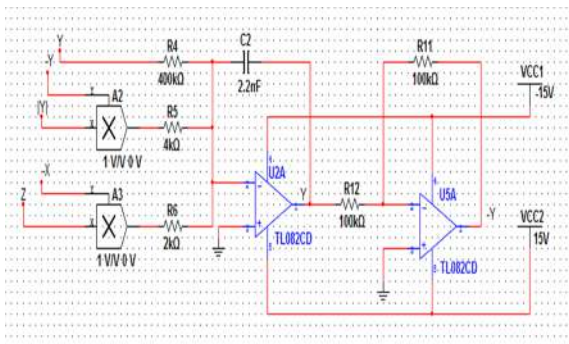

(b)

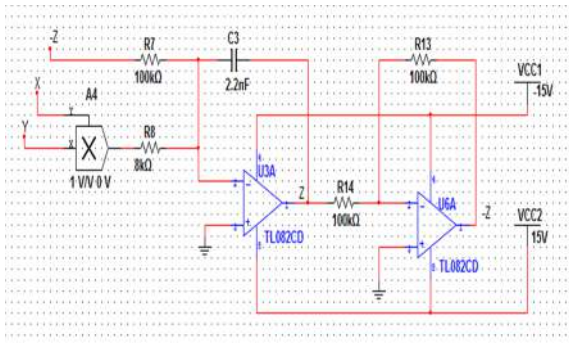

(c)

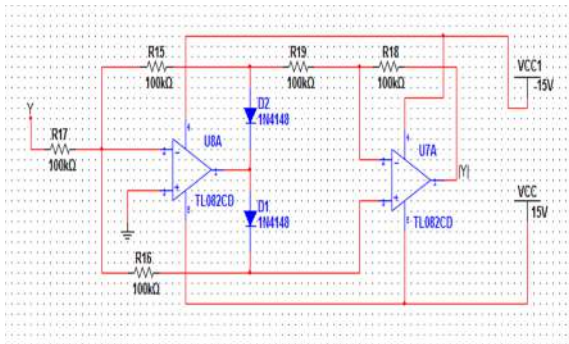

(d)

Figure 6: Circuit design of the new chaotic system (1) (a) x signal, (b) y signal, (c) z signal, and (d) |y| signal

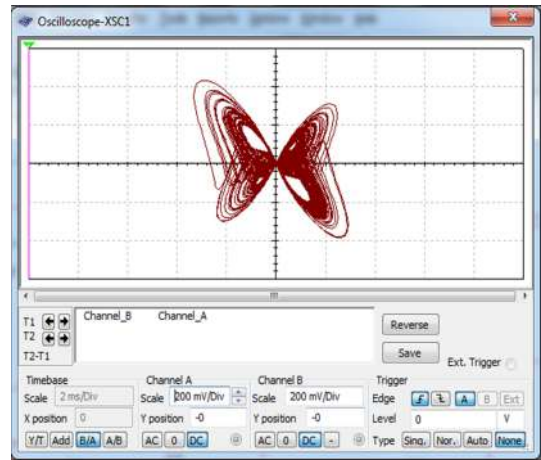

(a)

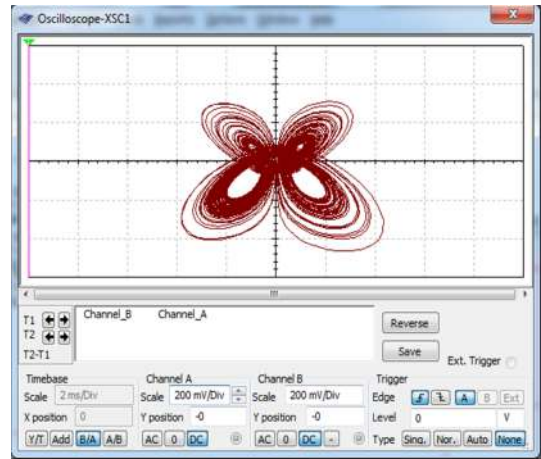

(b)

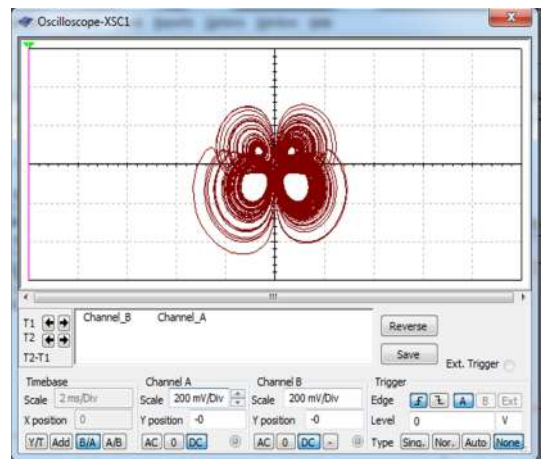

(c)

Figure 7: Chaotic attractors of the new chaotic system (1) using Multisim circuit simulation: (a) x – y plane, (b) y – z plane, and (c) x – z plane.