

The Ideal Plasticity Theory Usage Peculiarities to Concrete and Reinforced Concrete

Volodymyr Pohribnyi^{1*}, Oksana Dovzhenko², Olena Maliovana³

¹Poltava National Technical Yuri Kondratyuk University, Ukraine

¹Poltava National Technical Yuri Kondratyuk University, Ukraine

¹Poltava National Technical Yuri Kondratyuk University, Ukraine

*Corresponding author E-mail: v.v.pogrebnoy1960@gmail.com

Abstract

The usage aspects of ideal plasticity theory for concrete and reinforced concrete are investigated. The plastic deformation is considered to be localized in thin layers on the failure plane which divides the element into rigid parts. The variation method is used and the solutions in discontinuous functions are received. The functional of virtual velocities principle is investigated to stationary condition, the minimal capability of plastic deformation is found with which the solid changes into the mechanism. The limit and realization criterion of concrete failure under shear are set. The reinforcement influence on the element load-carrying capacity is taken into account.

Keywords: Shear, Plasticity theory, Variation method.

1. Introduction

One of the most significant challenges of nowadays is the building efficiency raise. The development of sufficiently general theoretically grounded calculation methods is actual for new building structures creation and providing the reliable operation of existing buildings and structures. It is of essential sense for concrete and reinforced concrete elements as their work differs by complication and variety of behavior under loading and identifies by many factors. Using the empirical relations does not rarely lead to significant inaccuracies that correlate with their limitations by experiment conditions. Meanwhile, the significant success has been obtained by the deformable solid mechanics classical theories usage [1 – 4], which has found numerous experimental confirmation [5 – 7]. For carrying capacity estimation of concrete and reinforced concrete structures, the most advanced are the brittle failure mechanics by the breaking form of their integrity, and the plasticity theory by the shear and fragmentation.

Mathematical tool of ideal plasticity theory has been grounded, as well as repeatedly approved on plastic materials, in particular steel [2 – 4, 8].

Based on plasticity theory the strength of massive and flat concrete elements under fragmentation has been determined [9, 10]. The most known tasks are stamping the concrete into the concrete base and limit equilibrium of symmetric compressed wedges with a cut facet within flat stress state and flat deformation conditions [9]. The characteristic lines method has been used. The plastic deformation has been considered to be localized in fields with stress state of uniaxial and biaxial compression that fit to stamp and wedge top.

The use of plasticity theory for concrete and reinforced concrete under shear has certain precautions that deal with their externally brittle character of failure. At the same time it should be pointed out that shear is realized only under condition of intense deformation presence and is its result. The concentrated deformation in

the shear area is also confirmed by the results of experimental research [11 – 13].

Plasticity theory provides for the plastic deformation localization directly near the failure surface [8, 14, 15]. Widely known discrete strength tasks solutions of plastic material elements are no less effective than those that take into account the intense deformation areas voluminosity.

The pointed out information grounds the localization of plastic deformation in thin layers on the displacement surface of concrete and reinforced concrete elements in low-deformed adjacent regions.

The purpose of this work is to establish the peculiarities and to confirm the usage perspective of ideal plasticity theory for concrete and reinforced concrete.

2. Basic Material

If the application results of the plasticity theory mathematical tool to concrete for its fragmentation may be referred to classical conception, then they need additional detailing and confirmation under shear.

Problems of concrete and reinforced concrete strength under shear hold a prominent place in general strength theory and have a significant practical value. The depth of their knowledge in a greater degree determines its development level and optimality of elements number structural solutions and connection joints.

Greater attention to the study of shear phenomenon in concrete devoted since the 90's of the 19th century, but the problem could not be treated as completely solved so far.

Whereas it is necessary to solve many practical strength tasks of concrete and reinforced concrete elements under the action of shear forces (beams and slabs in the zone of transverse forces action, short elements, key joints of slabs with girders and with each other, girders with columns and columns with foundations in the frame constructions, joints of wall panels in the frameless

constructions, contact joints of cast-in-place and precast constructions etc.), the question of concrete strength to so-called "pure shear" $f_{c,sh}$, becomes of particular importance. Its solving and the use of superposition principle – stress overlapping of shear, compression, and tension, would determine the strength of any construction destroyed under shear.

Definition of "pure shear" concept is of sufficient importance. In the mechanics of rigid deformed body it is understood under "pure shear" such kind of flat stress state, in which only tangential stresses act on two mutually perpendicular planes oriented in a certain way [1]. In this case, the deformations are characterized primarily by a right angles change of rectangular element, and the main stresses σ_1 and σ_2 are equal to each other in absolute value, are opposite in sign and are directed at the angle of 45° to the facets of rectangle. Consequently, on the limit surface in σ_1, σ_2 axes above-noted definition "pure shear" responses to the point in "tension-compression" area that lies on the bisecting line of the coordinate angle.

At the same time, the scientific works devoted to the research of concrete and reinforced concrete structures include certain characteristics in the "pure shear" definition. These characteristics are related to the failure character of elements under shear action, in particular: in pure form shear corresponds to the element separation in two parts along the section, where the shearing forces act and by means of displacement along the plane on which only tangential stresses act [2, 3].

Above-named "pure shear" definitions point out or unite two aspects of considered effect: the forced one – "pure shear" as a case of flat stress state that is characterized by acting of only tangential stress, and the cinematic one – "pure shear" as a failure mode that is characterized by the relative displacement of element parts which are separated by the shear plane.

In an attempt to combine above-named aspects of considered effect for concrete, searching of "the most relevant" sample was made for evaluation of concrete shear strength characteristics $f_{c,sh}$ over the decades. Such searching direction looked like logical enough and corresponded with known experimental data for plastic materials which had the pointed compatibility as possible. Experimental study of "pure shear" is actually divided in two directions, corresponding to one of the sides of the phenomenon under consideration. However, to date, no sample has been found that allows to combine the stress state of "pure shear" with the form of failure by shear. These difficulties, in our opinion, can not be overcome, since the desire to find the "most suitable" sample in the above-mentioned understanding does not take into account the real mechanical properties of concrete. For structurally inhomogeneous stone materials having different compression and tension resistance, the phenomena of "pure shear" as a case of a flat stress state and a form of failure are not compatible. That is, for concrete it is necessary to distinguish between two interpretations of the "pure shear" concept, having independent significance. These interpretations are very different: the first one is a "pure shear" as a particular case of a stress state, it is important in the development of strength theories, the second one - as a failure form, it is often encountered in practical tasks.

Researchers are offered by a variety of empirical dependencies for determining the concrete resistance to shear $f_{c,sh}$ as a function of concrete strength on compression $f_{c,cube}(f_{c,prizm})$, tension f_{ct} and both strength properties. The analysis of these dependencies shows a large discrepancy in the numerical values of the resistance to shear obtained by various authors, and almost all of them are confirmed by actual series of experiments. It testifies to their private nature, which is determined by the shape of the sample, the loading scheme and the conditions for conducting the experiment. Due to the variety in the construction practice of shear cases as failure forms it is impossible to establish a single characteristic of the concrete strength under shear. Only its particular values are obtained for individual cases. This leads to the domination of empirical dependencies in the strength calculations of concrete and

reinforced concrete elements and the impossibility of optimizing the constructive decisions of elements on their basis. Therefore, the development relevance of a sufficiently general and precise strength calculation theory of concrete and reinforced concrete elements under shear on the basis of the mechanics of a deformable solid is evident.

Characteristic features of such a scientific theory should be its commonality, the ability to explain the physical essence of a sufficiently wide range of known phenomena, to predict new dependencies, properties and phenomena, to describe with the necessary accuracy the quantitative relations of the processes parameters under consideration. The theory should be simple enough, to use standard tasks solving programs for its realization, easy to learn by users, to base on the elements failure stage consideration, and the design schemes to visualize the kinematics of the failure mechanisms.

When applying the plasticity theory, it is important to consider the development peculiarities of the deformable solid ultimate state from structurally inhomogeneous materials, to which concrete belongs.

This process leads to the formation of a ultimate macroscopical structure, the so-called kinematic mechanism. Its development is due to the achievement of the ultimate state of the body in the most intense and deformed region (the region of failure), where irreversible deformations are localized, due to which parts of the solid that are divided by the failure surface, acquire the possibility of mutual movement [16].

By character, two opposite types of kinematic mechanism are distinguished – brittle and plastic. In the first case, the level of stress and strain dominates in the tension zone, in which the microcrack of separation is formed, the sudden spread of which leads to brittle fracture. At the same time, the ultimate state in the compressed zone does not occur. As an example of a brittle kinematic mechanism is the structure of a concrete beam in the failure stage. To determine the strength of elements with such a failure mechanism, the most preferred is the brittle failure mechanics. In the plastic kinematic mechanism, the deformation process in the ultimate state passes more gradually (continuously). A characteristic feature of the plastic kinematic mechanism is the simultaneity of the existence of an ultimate state in the entire failure region, which is not possible under a brittle kinematic mechanism. This behavior of the plastic kinematic mechanism is due to the sufficient resource of materials plastic deformations of a deformable solid, for which a diagram of an elastic-plastic or rigid-plastic body with a limited range of ductility can be used.

The plastic properties of the concrete depend on many factors, of which the type and strength of concrete are the most important, as well as the character of the stress-strain state. For example, with average compressive stresses, plastic properties increase significantly.

Concrete deformation diagrams « $\sigma - \varepsilon$ » with sufficient accuracy can be approximated by a polygon consisting of three sections: the initial ascending, horizontal section of the conditionally ideal plasticity of a limited length at the limit stresses values and the descending - under extraterrestrial states. Usually an obstacle to applying ideal plasticity to concrete is the limitation of conditional plasticity length site on the approximated diagram " $\sigma - \varepsilon$ " for concrete. However, even for materials with increased plastic properties, a limited range of ideal ductility is actually used. Analysis of the concrete deformation diagrams indicates a significant increase in the intensity of plastic deformation at its top, especially in the area of the downward branch, which confirms the perspective of the plasticity theory [16]. At the same time, using the ideal plasticity theory for concrete, the question arises about the plastic deformations resource required in certain strength problems to ensure the simultaneity of an ultimate state existence across the entire failure area.

Among the prerequisites for creating a calculation method the concept of rigid-plastic body is used. The model of the localization of plastic deformation in a thin layer on the failure surface leads to really simple methods for assessing the strength of ele-

ments in complex inhomogeneous stress-strain states and is therefore attractive for use in practice. Plastic failure is characterized by large inelastic deformations without disturbance of macroscopicity (without macrocracks).

The presentation of concrete as a rigid-plastic body makes it possible to apply to it the ideal plasticity theory. The concept of rigid-plastic body allows us to apply the principle of virtual velocities, discontinuous solutions, an upper bound of the boundary load and creates conditions for a certain simplification of the strength problems. In a homogeneous ultimate stress-strain state, shear is realized in the local most stressed zone, in the inhomogeneous one - in the compressed failure area, which divides the body into rigid parts that make a mutual movement due to localized inelastic deformations. A qualitative criterion for the applicability of the plasticity theory can be formulated as the existence possibility (at least for a moment) of the plasticity conditions (strength) across the entire region of the concrete ultimate state, completely intersecting the body, the development of which is necessary for its transformation into a kinematic mechanism [17]. At the same time, the externally brittle failure character is not an obstacle to the shear realization and the inapplicability of the plasticity theory.

The task solution of the plasticity theory on the basis of differential equations is a rather complicated process. When calculating the ultimate load in the case of plane problems, the method of characteristics is sufficiently precise [9, 18]. However, the most versatile and simple is the variational method [16], the method of the ultimate equilibrium theory. In variational calculations, the solution is based on energy perceptions of a deformed solid, first of all, on the energy of deformation and its extreme properties.

As a plastic potential the concrete strength condition of Balandin – Geniev is offered [9]. This condition is rather exact and simple in writing in tensor form and is represented as rotational paraboloid

$$F(\sigma_{ij}) = T^2 + m\sigma - T_{sh}^2 = 0, \quad (1)$$

where $m = f_c - f_{ct}$, $T_{sh}^2 = \frac{f_c f_{ct}}{3}$, here f_c and f_{ct} – concrete strength to compression and tension; T – intensity of tangential stress; σ – average stress.

When compression strength equals to tension strength, it becomes classic condition of Mizes, according to that intensity of tangential stress remains constant.

Condition (1) in τ_n, σ_n coordinates has the following equation

$$|\tau_n| = f(\sigma_n) = \sqrt{K^2 - 0,25(\sigma_n - m)^2}, \quad (2)$$

where $K = \tau_{\max} = \frac{1}{\sqrt{3}} \sqrt{f_c^2 - f_c f_{ct} - f_{ct}^2}$.

Dependence between deformations velocity ε_{ij} and stress σ_{ij} determines by associate yielding law.

The functional of virtual velocities principle is used for strength tasks solving [13]. This functional in general form is written as following in the absence of inertial and mass forces

$$J = \int_{S_l} W_{cl} dS - \int f_i^* V_i dS - \int f_i V_i^* dS, \quad (3)$$

where W_{cl} – specific capacity of plastic deforming of concrete; f_i^*, V_i^* – forces and velocities that are relatively presented on S_f and S_V areas of element surface $S = S_f \cup S_V$.

Limit load value is determined as one that responses to minimum capacity of plastic deformation. And this deformation is localized in the thin layer with thickness $n \rightarrow 0$ on the failure surface.

First part of functional (3) for flat stress state is written with the velocity jumps on the failure surface as following

$$J_1 = \int_{S_l} m \left[B \sqrt{4\Delta V_n^2 + \Delta V_t^2} - \Delta V_n \right] dS, \quad (4)$$

where $B = \sqrt{(1 + f_c f_{ct} / m^2) / 3}$; ΔV_t and ΔV_n – velocities jumps

in tangential and normal to failure surface S_l directions (concrete volume increasing in ultimate state is taken into account – dilatancy).

Stresses on the failure surface in general form are determined as following

$$\sigma_n = m - 2K \frac{\Delta V_n}{\sqrt{\Delta V_n^2 + 0,25\Delta V_t^2}}, \quad (5)$$

$$\tau_n = K \frac{\Delta V_t}{2\sqrt{\Delta V_n^2 + 0,25\Delta V_t^2}}. \quad (6)$$

Selection of kinematically possible scheme is made for every failure case, and its specificity is reflected in the functional. The geometry of failure surface is varied, on which velocity breakups (jumps) ΔV_t and ΔV_n , and also angle ψ between the surface and velocity direction of one element part to another is varied. As the result, the functional J is investigated to stationary condition with the help of variation equation $\delta J = 0$. This equation is equivalent to boundary problem solving and ultimate load minimum value determining.

Strength task of concrete plate in biaxial stress state conditions has been solved for checking of above-proposed mathematical tool. This plate is one of the basic samples for experimental confirmation of strength condition with known stress state and direction of principal planes.

Angle ψ determines the stress in element failure area by means of shear according to the accepted condition (1):

normal

$$\sigma_n = m - 4K \frac{tg\psi}{\sqrt{1 + 4tg^2\psi}}; \quad (7)$$

tangential

$$\tau_n = \frac{K}{\sqrt{1 + 4tg^2\psi}}; \quad (8)$$

principal normal

$$\sigma_1 = \sigma_n + \tau_n \left(tg\psi + \sqrt{1 + tg^2\psi} \right); \quad (9)$$

$$\sigma_2 = \sigma_n + \tau_n \left(tg\psi - \sqrt{1 + tg^2\psi} \right). \quad (10)$$

Kinematical failure scheme of plate is given in fig. 1. Velocities jumps on failure surface are

$$\left. \begin{aligned} \Delta V_n &= V_x \cos \gamma - V_y \sin \gamma \\ \Delta V_t &= V_x \sin \gamma + V_y \cos \gamma \end{aligned} \right\}, \quad (11)$$

its surface area and surface areas of plate, where the stresses σ_1 and σ_2 act, are equal consequently

$$S_l = b\delta / \sin \gamma, S_1 = b\delta, S_2 = b\delta / tg\gamma, \quad (12)$$

where δ – thickness of plate

The functional (3) is being written with account of (4), (11), (12), taking into consideration that velocity in stresses direction σ_1 and σ_2 action are $V_1 = V_y \tan \gamma$ and $V_2 = -V_x$ consequently

$$J = m \left[B \sqrt{4(V_x \cos \gamma - V_y \sin \gamma)^2 + (V_x \sin \gamma + V_y \cos \gamma)^2} - (V_x \cos \gamma - V_y \sin \gamma) \right] b \delta / \sin \gamma - \sigma_1 V_y b \delta - \sigma_2 V_x b \delta / \tan \gamma. \quad (13)$$

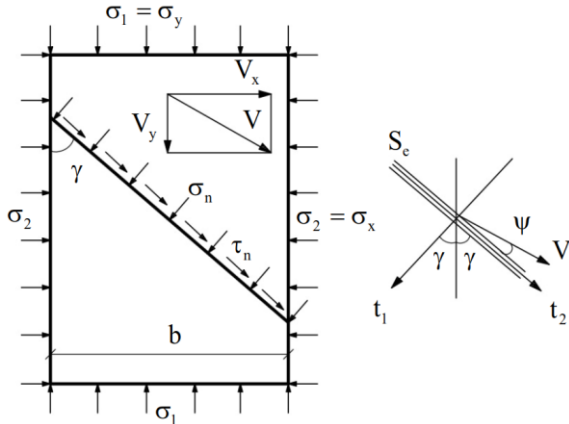

Fig. 1: Kinematically possible failure scheme of concrete plate with biaxial stress state:

t_1 and t_2 – possible directions of slide planes.

The functional becomes the following one after some simple transformations taking into account that $\kappa = V_x / V_y$

$$J = \frac{m \left[B \sqrt{4(\kappa - \tan \gamma)^2 + (1 + \kappa \tan \gamma)^2} - (\kappa - \tan \gamma) \right]}{\tan \gamma} - \sigma_1 + \frac{\kappa}{\tan \gamma} \sigma_2. \quad (14)$$

The formula for determining the stress σ_1 has been received from the equality of functional J to zero

$$\sigma_1 = \frac{m \left[B \sqrt{4(\kappa - \tan \gamma)^2 + (1 + \kappa \tan \gamma)^2} - (\kappa - \tan \gamma) \right]}{\tan \gamma} + \frac{\kappa}{\tan \gamma} \sigma_2. \quad (15)$$

Let's give consideration to characteristic points on the concrete strength condition.

Taking into account that angles ψ and γ are correlated one with another and with ratio k by the relation

$$\psi = \arctg \kappa - \gamma, \quad (16)$$

and writing $mB = K$ the following has been received

$$\sigma_1 = \left[\frac{\tan(\gamma + \psi)}{\tan \gamma} - 1 \right] \left[K \frac{\sqrt{1 + 4 \tan^2 \psi}}{\tan \psi} - m \right] + \frac{\tan(\gamma + \psi)}{\tan \gamma} \sigma_2. \quad (17)$$

When the formulation of concrete plastic deformation capacity by axial compression ($\sigma_2 = 0$) is accepted as the constituent, which is used by given below tasks solving

$$W_{c1} = \left[\frac{\tan(\gamma + \psi)}{\tan \gamma} - 1 \right] \left[K \frac{\sqrt{1 + 4 \tan^2 \psi}}{\tan \psi} - m \right] \quad (18)$$

the formula for value σ_1 determining in biaxial stress state conditions takes the form

$$\sigma_1 = W_{c1} + \sigma_2 \tan(\gamma + \psi) / \tan \gamma. \quad (19)$$

In the maximum tangential stress point (at $\psi = 0^\circ$) there is

$$\sigma_1 = m + K, \quad (20)$$

$$\sigma_2 = m - K. \quad (21)$$

Data about angles ψ and γ values, normal σ_1 , σ_2 , σ_n and tangential τ_n stresses on the displacement surfaces determined by (7–10) with different ratio of concrete strength to tension and compression χ are given in table 1.

Table 1: The calculation results in characteristic points of concrete strength condition

Parameter	At χ		
	0.15	0.1	0.05
In the point of maximum compression stresses			
ψ	-90°		
γ	90°		
σ_1/f_c	1.93	2	2.08
σ_2/f_c	1.39	1.45	1.51
σ_n/f_c	1.93	2	2.08
τ_n/f_c	0		
In the point of maximum tangential stresses			
ψ	0°		
γ	45°		
σ_1/f_c	1.39	1.45	1.51
σ_2/f_c	0.311	0.349	0.387
σ_n/f_c	0.85	0.9	0.95
τ_n/f_c	0.539	0.551	0.564
In the point of uniaxial compression: $\sigma_1=1, \sigma_2=0$			
ψ	38°15'	37°16'	36°16'
γ	13°30'	15°28'	17°28'
σ_n/f_c	0.383	0.367	0.35
τ_n/f_c	0.486	0.482	0.477
In the point of maximum tension stresses			
ψ	90°		
γ	0°		
σ_1/f_c	0.311	0.349	0.387
σ_2/f_c	-0.229	-0.201	-0.177
σ_n/f_c	-0.229	-0.201	-0.177
τ_n/f_c	0		

Stress values consist with specified concrete strength condition (1), which is taken as a basis of mathematic tool which is used.

One of the important tasks in developing of quite general design theory of concrete and reinforced concrete elements under shear are the area establishing of its realization.

Shear for plastic materials takes place in the presence of real displacement planes that are present on the stress states interval in coordinates of principle normal stresses σ_1, σ_2 , between the points of compression maximum stresses (in the biaxial compression area) and tension (in the biaxial tension area). For concrete the last one is shifted in the area of mixed stress states. Thereby the experimental research indicates the narrowing of pointed interval.

The boundary of shear realization in concrete is proposed to be established at points on the strength condition, the values of the angle ψ of which correspond to its magnitudes with uniaxial compression and tension of plastic materials, with the values equality of compression and tension strength.

The values of normal and tangential stresses that correspond to the boundaries of the shear implementation are given in table 2. For perception visibility of the obtained results the sections of concrete strength (plasticity) condition in the area of mixed stress states are given in fig. 2, where the shear failure form takes place. And this failure form is bordered with separation failure.

The analysis of the obtained results shows that in comparison with more plastic materials the boundary between shear and tear-off forms of failure is shifted in the direction of uniaxial compression (fig. 2).

For low strength concrete with high plastic properties the area of shear intervals is expanded (σ_1 / f_c from 1 to 0.85, σ_2 / f_c from 0

to -0.084 at $\chi = 0.15$) comparing to high strength concrete (σ_1 / f_c from 1 to 0.95, σ_2 / f_c from 0 to -0.026 at $\chi = 0.05$).

Table 2: Limit of the shear implementation in concrete in the zone of mixed stress states

Parameter	At χ		
	0.15	0.1	0.05
ψ	19°28'		
γ	35°16'		
σ_v / f_c	0.85	0.9	0.95
σ_2 / f_c	-0.084	-0.054	-0.026
σ_n / f_c	0.227	0.264	0.299
τ_n / f_c	0.44	0.45	0.46

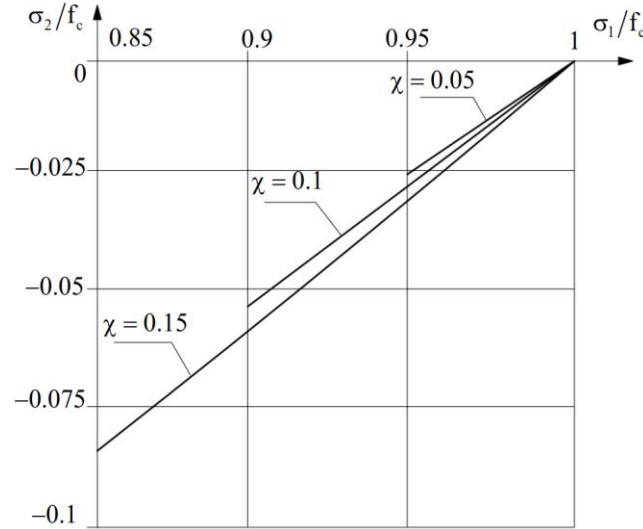

Fig. 2: Limit of the shear failure form implementation in concrete by the different ratios of tension and compression χ .

The lower boundary in the mixed stress states area corresponds to an angle $\psi = 19^\circ 28'$. The maximum tangential stresses occur in the region of non-uniform compression at an angle $\psi = 0$ and equal to the value of concrete characteristics K . The shear form is realized in concrete at the level of tangential stresses in the slide plane (failure surface) $\sqrt{2/3} \leq \tau_n / \tau_{max}$, that is determined by the formula (8) and in the area of mixed stress states under condition $\psi \leq \arcsin 1/3$.

These limits take into account the concrete properties. For most concrete elements the direction of external forces action does not coincide with the principal stresses.

Let's concrete plate loaded with normal σ and tangential τ stresses.

Kinematically possible failure scheme of such a plate is shown in fig. 3.

The value of relative stresses on the loaded facet of plane is equal to

$$\sigma = \frac{W_{c1}}{1 + tg(\gamma + \psi)tg\beta}, \quad (22)$$

$$\tau = \frac{W_{c1}tg\beta}{1 + tg(\gamma + \psi)tg\beta}, \quad (23)$$

where $tg\beta = \tau / \sigma$.

Such case of failure is realized in short consoles and beam-walls and in areas of bending elements at the supports. The boundary value of the relative load under sloping strip shear at different angles of its inclination (fig. 4) is determined by the dependence

$$\frac{V_u}{b\delta} = \frac{W_{c1}}{[\sin\theta + tg(\gamma + \psi)\cos\theta]}, \quad (24)$$

where b and δ – width and thickness of the strip.

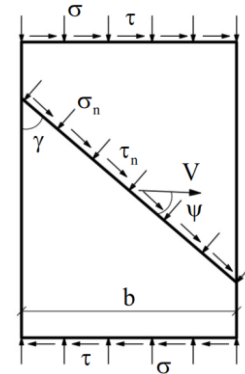

Fig. 3: Kinematically possible failure scheme of a concrete plane loaded at the ends with a normal and tangential force.

The calculation results are given in table 3.

Table 3: Calculation results of concrete plate strength with the joint action of surface stresses σ and τ

Angle $\beta, ^\circ$	Parameters-characteristics at $\chi = 0.1$					
	$\psi, ^\circ$	$\gamma, ^\circ$	σ_n / f_c	τ_n / f_c	σ / f_c	τ / f_c
10	19.59	40.2	0.261	0.449	0.792	0.14
20	23.38	43.31	0.179	0.417	0.621	0.226
30	26.96	46.52	0.115	0.386	0.481	0.278
40	30.39	49.8	0.062	0.357	0.364	0.305
45	32.08	51.46	0.039	0.343	0.312	0.312
50	33.75	53.1	0.018	0.33	0.265	0.316
60	35.3	54.7	0.001	0.318	0.183	0.318
70	35.31	54.7	0	0.318	0.116	0.318

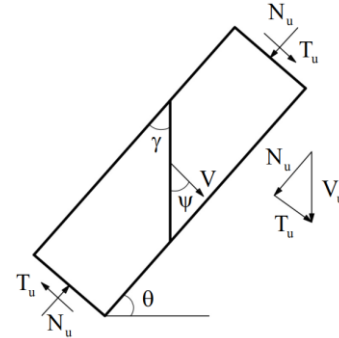

Fig. 4: Kinematically possible scheme of failure of an inclined compressed strip.

It should be noted that the area of shear implementation in the inclined strip extends to the action of compression stresses $\sigma_n \rightarrow 0$ due to the limitation of transverse deformations in its work in the structure. This is evidenced by the consideration of shear failure form in the norms of Eurocode [19] when calculating the strength of the compressed element on the action of transverse force provided $ctg\theta = 2.5$, where $\theta = 21,8^\circ$, $\beta = 90^\circ - 21,8^\circ = 68,2^\circ$ (see table 1).

The wedges simulate the strength of the compressed zone of concrete over the dangerous inclined crack of reinforced concrete bending elements. These wedges are loaded with normal and tangential forces behind the cut facet.

The failure of such wedges is possible in two schemes: at the right angle between the horizontal and the cut facets and near the blunt angle (fig. 5).

The first case of failure, as the experimental research shown [20], is realized under the action of tangential forces in the direction to the right angle, or from it at small values T .

The second case of wedge failure occurs when it is directed towards a blunt angle with increasing values $tg\beta = T / N$ and depends on the wedge angle α unlike the first case.

The ultimate load in the first case of wedge failure is determined from the equation

$$\frac{V_u}{bh} = \frac{tg\beta}{1 \pm tg(\gamma + \psi)tg\beta} W_{c1}, \quad (25)$$

where b and h – width and height of the wedge cut facet.

In the formula, the sign “+” corresponds to the direction of transverse force V to the right angle, and the sign “-” corresponds to the V direction from the right angle. In the second case of failure the ultimate load equals

$$\frac{V_u}{bh} = \frac{[1 + tg\alpha / (tg\gamma - tg\alpha)]tg\beta}{1 + tg(\gamma + \psi)tg\beta} W_{c1}. \quad (26)$$

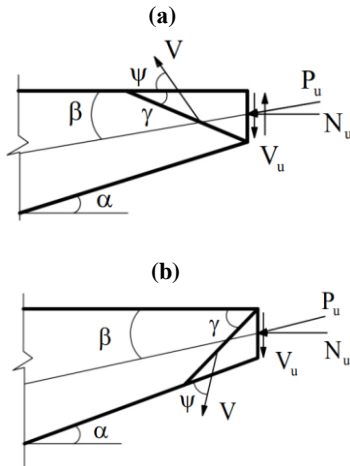

Fig. 5: Kinematically possible scheme of wedge failure as the models of the compressed zone of concrete over the dangerous inclined crack: 1st (a) and 2nd (b) failure cases.

The calculation results of concrete wedges are given in table 4. At local compression of a concrete plate under the loaded area a seal wedge is formed, over the facets of which the plastic deformation is concentrated [21]. In ratio of the plate height to the length of the loading area under the wedge there is a tensioned zone with stresses along the tearing plane f_{ct} . Depending on the load transfer scheme, there are two cases of failure. The kinematic failure scheme with one-sided and double-sided local compression is shown in fig. 6.

Table 4: The calculation results of the concrete wedges strength

Angle of inclination $\beta, ^\circ$	Characteristics at $\chi = 0.1$			
	$\psi, ^\circ$	$\gamma, ^\circ$	$\frac{N_u}{f_c bh}$	$\frac{T_u}{f_c bh}$
First case of failure				
-5	38.71	17.58	0.891	0.078
5	35.89	13.22	1.12	0.098
10	34.6	10.79	1.25	0.221
15	33.43	8.14	1.4	0.375
20	32.42	5.16	1.56	0.567
Second case of failure				
$\alpha=15^\circ$				
0	8.14	48.43	1.4	0
10	13.22	50.89	1.07	0.189
20	17.58	53.71	0.812	0.296
$\alpha=30^\circ$				
10	5.16	62.42	1.41	0.249
20	10.79	64.6	1.04	0.377
30	15.47	67.27	0.75	0.433
$\alpha=45^\circ$				
20	1.67	76.67	1.27	0.462
30	8.14	78.43	0.887	0.512

(a)

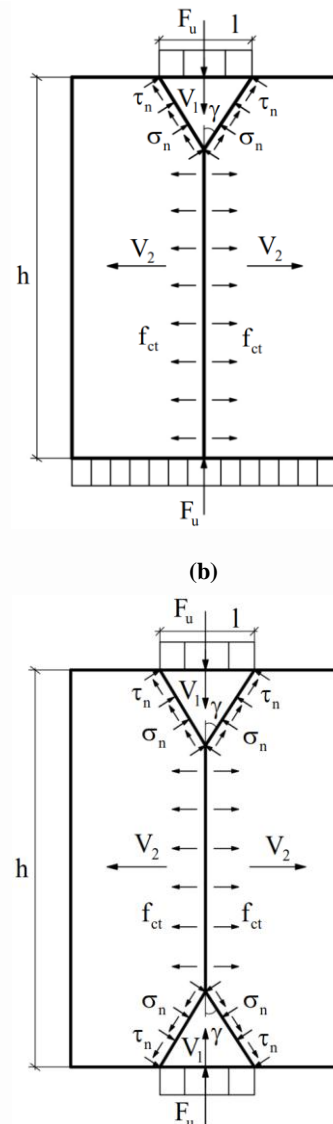

Fig. 6: The kinematic failure scheme of concrete plate with one-sided and double-sided local compression: one-sided (a); double-sided (b).

The value of the boundary load on the plate in one-sided and double-sided local compression is accordingly determined by the dependencies:

$$\frac{F}{f_c b \delta} = W_{c1} + tg(\gamma + \psi)\chi \left(2\frac{h}{l} - \frac{1}{tg\gamma} \right), \quad (27)$$

and

$$\frac{F}{f_c b \delta} = W_{c1} + tg(\gamma + \psi)\chi \left(\frac{h}{l} - \frac{1}{tg\gamma} \right). \quad (28)$$

Shear in concrete is realized both at homogeneous stress state of the failure zone, and in the presence of compression areas and tension. [12, 20 – 26]. In a heterogeneous stress state, the criterion of the shear implementation is the simultaneous existence of an ultimate stress state on the entire failure surface. It is possible only if the stress level in the compression zone exceed the stress level in the tension zone at the stages preceding the failure. That is, failure from shear occurs throughout the entire section simultaneously in the compression and tensile zone.

It should be noted that the shear failure form of bending concrete elements looks like a sudden breaking away avalanche-like character, and with the relative shear span $0.15 \leq c/h \leq 0.4$ it is visually difficult to distinguish the shear form from the breaking. Only in the case of pointed ratio increase a clearly expressed breaking form takes place with a characteristic for it low deformed failure zone, the determining resistance f_{ct} and a sharp decrease of the ultimate load value. In the case of insignificant influence of bend-

ing moment M conditions are created for the plastic deformations localization on the failure surface in the compressed zone, that is an essential requirement for the shear form implementation. This form combines the external fragility and the presence of intense directional deformation in thin concrete layers. The pointed fact is characteristic for pseudoplastic materials with a large difference in the strength values f_c and f_{ct} , which include concrete.

When designing concrete elements it is necessary to avoid their failure by breaking, that necessitates the introduction of a c/h value limitation. This limitation would correspond to the boundary of the shear failure form, which, despite the external avalanche-like character, makes it possible to use the plastic properties of concrete even in a thin layer on the shear surface. The strength at shear is higher than at breaking and depends both on the resistance f_c and on the characteristics f_{ct} . Strength lowering with increasing of c/h occurs more slowly than at the breaking.

To establish the boundary between the above noted forms of failure, let's consider the distribution of stresses in the normal section at the breaking (fig. 7, a). The effort taken by the concrete element is determined from the zero equation of the moments sum

$$M_u = V_u c = f_{ct} W_{pl}, \quad (29)$$

where $W_{pl} = bh^2 / 3,5$ – plastic moment of rectangular cross section resistance.

Let's write down the given dependence in the form

$$f_{sh} c = 0,29 \alpha f_{ct} h, \quad (30)$$

where $f_{sh} = V_u / bh$, coefficient $\alpha = 1$ with a dominant influence of M and $\alpha > 1$ – for short elements.

Stresses in the area near the supports of bending elements significantly exceed the strength f_{ct} . during the failure. This is due to the influence of the principal compression stresses.

Taking into account that the failure surface under shear (fig. 7, b) is close to the normal section, it is possible to equate the stresses f_{sh} and αf_{ct} , to establish the boundary between the shear and the breaking, and $c/h = 0,29$. is obtained from the formula (28).

According to the results of experimental researches for the ratio of concrete resistance $\chi = 0.1$ the boundary between the shear and the breaking away of concrete keys has been fixed at $c/h = 0.3$.

According to the strength task solving of beam concrete element based on ideal plasticity theory the shear stresses at $c/h = 0,3$ are $f_{sh} = 1,4 f_{ct}$. The shear stresses were obtained by formulas (32), (33) at $\sigma = 0$.

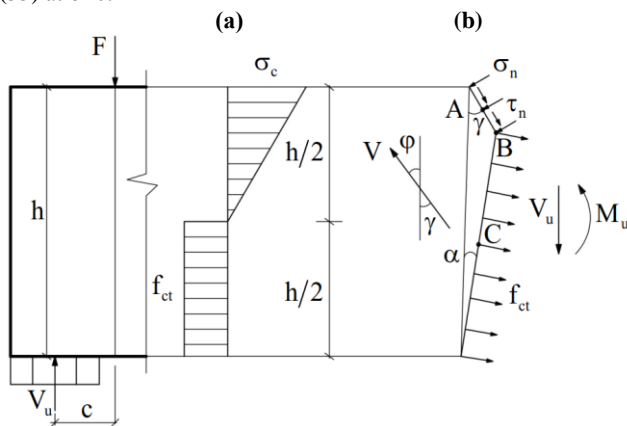

Fig. 7: For strength calculating of bending concrete element in the normal section: the distribution of forces in the section at the breaking away (a) and at the shear (b).

For reinforced concrete elements the implementation area of the failure shear form is expanding. The influence of reinforcement is taken into account by applying on the calculation schemes of external compressive forces in the locations of the reinforcement.

The moment, which is perceived by the reinforced concrete element in the normal section (fig. 8, a), is determined by the formula

$$M_u = V_u c = \bar{\alpha}_m f_c b d^2, \quad (31)$$

where $\bar{\alpha}_m = \rho \frac{f_y}{f_c} \left(1 - \bar{\chi} \rho \frac{f_y}{f_c} \right)$ – relative moment that is perceived

by an element, b and d – width and working height of the section, ρ – reinforcement factor, f_y and f_c – the yielding point of reinforcement and the resistance of concrete compression, $\bar{\chi}$ – a coefficient that takes into account the application place of the resulting force in the concrete compressed zone.

The ultimate value of transverse force for the shear form of failure is equal to $V_u = f_{sh,cs} b d$ and is determined by the resistance to shear $f_{sh,cs}$, of reinforced concrete element. This resistance is established when solving this strength problem by the variation method in the plasticity theory.

The resistance $f_{sh,cs}$ of the bending reinforced concrete element in the approximate normal section (fig. 8, b) is equal to

$$f_{sh,cs} = tg \gamma \left[W_{c1} \frac{tg \alpha}{tg \alpha + tg \gamma} + \chi \frac{tg(\gamma + \psi) + tg \alpha}{tg \alpha + tg \gamma} \right] + tg(\gamma + \psi) \sigma, \quad (32)$$

where $\sigma = \rho f_y$ – pressing stress.

Three equations of equilibrium are used as additional conditions:

$$M_A = 0, M_B = 0. \text{ and } M_C = 0. \quad (33)$$

The calculation results indicate that ψ is equal to zero.

Then the dependence (30) takes on a form

$$f_{sh,cs} = \sqrt{\frac{1 - \chi + \chi^2}{3}} (1 + tg^2 \gamma) \frac{tg \alpha}{tg \alpha + tg \gamma} f_c + tg \gamma (f_{ct} + \sigma). \quad (34)$$

The equation (31) can be represented as

$$c / d = \bar{\alpha}_m f_c / f_{sh,cs}. \quad (35)$$

The shear resistance value $f_{sh,cs}$ also depends on the ratio c / d .

Setting the parameter c / d with conditions (33) the value of $f_{sh,cs}$, is being found from (34) by the iteration method. And at this value the equation (35) is executed. When reinforcing the element with a longitudinal reinforcement of class A400C with reinforcement percentage of 1,5% and the concrete class on the compression C30/35, the shear implementation boundary corresponds to the ratio of $c / d = 1$.

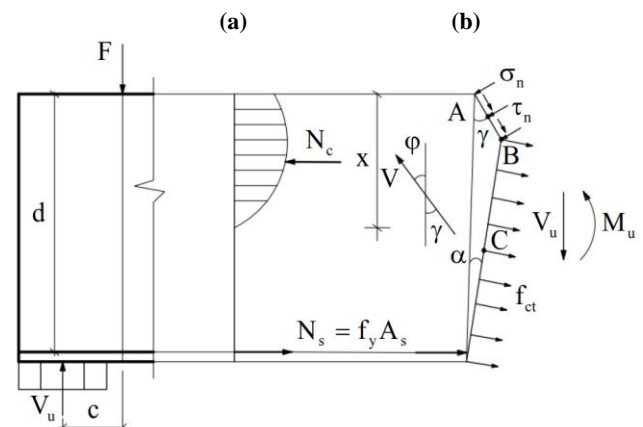

Fig. 8: For setting the failure boundary of a reinforced concrete element by concrete fragmentation in the compressed zone at reinforcement yielding (a) and at shear (b).

3. Conclusion

The theory of ideal plasticity is perspective for the solution of the strength tasks of concrete and reinforced concrete elements under shear.

Features of its application for concrete and reinforced concrete consist of: possibility of solving strength tasks with external avalanche-like failure character by shear; localization of intense deformation in thin layers on the displacement surface in the compression zone; taking into account the abruptions (jumps) of velocity in the direction normal to the failure surface; advanced stress level in the compression zone above the stress level in the tension zone at the stages preceding the failure in conditions of heterogeneous stress-strain state; simultaneity of reaching the ultimate state on the entire failure surface; clarification of the shear area realization in concrete and reinforced concrete compared with plastic materials. Failure through the shear occurs in the entire section.

The application of the variation method in the plasticity theory allows to obtain theoretically reasoned, sufficiently simple and precise solutions of practical significance.

References

- [1] Mielnik EM (1991), *Metalworking Science and Engineering*, McGraw-Hill, New York, London, 976 p. ISBN 0-07-041904-3.
- [2] Mineola LJ (2008) *Plasticity theory*, Dover, NY, 969 p. ISBN 9780486462905.
- [3] Nielsen MP & Hoang LC (2011), *Limit Analysis and Concrete Plasticity*, CRC Press, Taylor & Francis Group. 3rd ed., 669 p. ISBN 781439803967.
- [4] Ivlev DD (2001), *Mechanics of Plastic Media. T. 1. Theory of Ideal Plasticity [Mekhanika plasticheskikh sred. T. 1. Teoriya ideal'noj plastichnosti]*, Fizmatlit, Moscow, Russia, 448 p. ISBN 5-9221-0140-4. (In Russian).
- [5] Minhho J, Yang MK, Byeong-Joo L, Börje J, Levente V & Se KK (2014), Theory for plasticity of face-centered cubic metals, *PNAS*, 111 (18), pp. 6560-6565, <https://doi.org/10.1073/pnas.1400786111>
- [6] Wilson CD (2002), A Critical Reexamination of Classical Metal Plasticity, *Journal of Applied Mechanics*, Vol. 69, Iss. 1, pp. 63-68, DOI:10.1115/1.1412239
- [7] Ashour A & Yang K-H (2008), Application of plasticity theory to reinforced concrete deep beams: A review, *Magazine of Concrete Research*, Vol. 60, Iss. 9, pp. 657-884, <https://doi.org/10.1680/macr.2008.00038>
- [8] Kachanov LM (1969), *Basic of the plasticity theory [Osnovy teorii plastichnosti]*, Moscow, Russia, 420 p. (2013) Ripol Klassik, 426 p. ISBN 5458436059, 9785458436052. (In Russian).
- [9] Geniyev GA, Kissyuk VN & Tyupin GA (1974), *Concrete and reinforced concrete plasticity theory [Teoriya plastichnosti betona i zhelezobetona]*, Moscow, Russia, 316 p. (In Russian).
- [10] Grassl P, Lundgren K & Gylltoft K (2002), Concrete in compression: a plasticity theory with a novel hardening law, *International Journal of Solids and Structures*, Vol. 39, Iss. 20, pp. 5205-5223, [https://doi.org/10.1016/S0020-7683\(02\)00408-0](https://doi.org/10.1016/S0020-7683(02)00408-0)
- [11] Sørensen JH, Hoang LC, Olesen JF & Fischer G (2017), Test and analysis of a new ductile shear connection design for RC shear walls, *Structural Concrete*, Vol. 18, Iss. 1, pp. 189-204, <https://doi.org/10.1002/suco.201600056>
- [12] Kim HS, Chin WJ, Cho JR, Kim YJ & Yoon H (2015), An Experimental Study on the Behavior of Shear Keys According to the Curing Time of UHPC, *Engineering*, Vol. 7, No 4, pp. 212-218, <http://dx.doi.org/10.4236/eng.2015.74017>
- [13] Dovzhenko O, Pogrebnyi V, Yurko I, Shostak I (2017), The bearing capacity experimental determination of the keyed joints models in the transport construction, *Web of Conferences*, Vol. 116, <https://doi.org/10.1051/mateconf/201711602011>
- [14] Kolmogorov VL (1986), *Metal forming mechanics [Mekhanika obrabotki metallov davleniyem]*, Moscow, Russia, 689 p. (In Russian).
- [15] Ebobisse F & Reddy BD (2004), Some mathematical problems in perfect plasticity, *Comput. Methods Appl. Mech. Engrg.*, Vol. 193, pp. 5071-5094, DOI: 10.1016/j.cma.2004.07.002
- [16] Mitrofanov VP (2006), The theory of perfect plasticity as the elementary mechanic pseudo-plastic ultimate state of concrete: bases, imitations, practical aspects, *Proc. of the 2nd fib. Congress*, Naples, Italy, pp. 7-6.
- [17] Mytrofanov V, Dovzhenko O, Pogribnyi V (2002), About applying possibility premise ideal plasticity for concrete [Pro mozhyvist' zastosuvannya peredumovy pro ideal'nu plastychnist' do betonu], *Bulletin of the Odessa State Academy of Civil Engineering and Architecture [Visnyk ODABA]*, Odesa, Ukraine, Vol. 7, pp. 118 – 124. (In Ukrainian).
- [18] Mitrofanov V, Pogrebnyi V, Dovzhenko O (2006), Strength of Concrete Elements Under Shear Action According to the Theory of Plasticity and Tests, *Proc. of the 2nd fib Congress*, Naples, Italy, pp. 284-285.
- [19] Eurocode 2, Part 1 Design of concrete structures, EN 1990:1992 (1992), [Publication Date 1992-11-23], 292 p. (European standard).
- [20] Dovzhenko OO, Pohribnyi VV, Usenko IS, Mal'ovana OO, Akopyan MK (2016), Concrete Elements Strength Under The Shear Action According To The Variation Method In The Theory Of Plasticity And Tests, *ISJ Theoretical & Applied Science*, 12 (44), pp. 12-18, <http://dx.doi.org/10.15863/TAS.2016.12.44.3>
- [21] Pohribnyi V, Dovzhenko O, Karabash L, Usenko I (2017), The design of concrete elements strength under local compression based on the variational method in the plasticity theory, *Web of Conferences*, Vol. 116, <https://doi.org/10.1051/mateconf/20171160201>
- [22] Dovzhenko OA, Pohribnyi VV, Karabash LV (2018) Effective Keyed Connections Of Hollow-Core Floor Slabs With Walls In Modern Large-Panel House Building, *Science & Technique*, 17(2), pp. 146-156. (In Russian), 10.21122/2227-1031-2018-17-2-146-156
- [23] Lee ChH, Chin WJ, Choi ES & Kim YJ (2011), An Experimental Study on the Joints in Ultra High Performance Precast Concrete Segmental Bridges, *J. of the Korea Concrete Institute*, Vol. 23 (2), pp. 235-244, <https://doi.org/10.4334/JKCI.2011.23.2.235>
- [24] Dovzhenko O, Pogrebnyi V, Yurko I (2018), Shear Failure Form Realization in concrete, *News NAS RK. Series of geology and technical science*, Vol. 2 (428), pp. 212-219.
- [25] Kim HS, Chin WJ, Cho JR, Kim YJ, Yoon H (2015), An Experimental Study on the Behavior of Shear Keys According to the Curing Time of UHPC, *Engineering*, Vol. 7, pp. 212-218, <http://dx.doi.org/10.4236/eng.2015.74017>
- [26] Haibo J, Li C, Zhongguo JM, Wenxian F (2015), Shear Behavior of Dry Joints with Castellated Keys in Precast Concrete Segmental Bridges, *Journal of Bridge Engineering*, Vol. 20, Iss. 2, [https://doi.org/10.1061/\(ASCE\)BE.1943-5592.0000649](https://doi.org/10.1061/(ASCE)BE.1943-5592.0000649)