

ZVS based switching technique mitigates the power losses using mosfet based full bridge dc converter

Durgam Kumara Swamy^{1*}, Dr. B. V. Sanker Ram²

¹ Research Scholar, JNTUH, Hyderabad

² Professor, Dept. of EEE, JNTUH, Hyderabad

*Corresponding author E-mail: dkswamy1213@gmail.com

Abstract

In today's vitality power industries Boost converters highly required to convert the normal power into improvised power. Normally vitality converters struggled with voltage pressure over the power electronics switching nature and undulation. The renewable energy of a kind that vitality Photovoltaic (PV)-cell sources, windmill and battery are the sources for the converters; in this Photovoltaic play a vital role and mostly used medium to provide converters for further processing. The vitality PV is basically acted along with solar power efficiency, which is improvised ZeroVoltage Switching [ZVS] converters. The Zero-Voltage Switching [ZVS] converters transforms the low-power DC energy to high-power or vitality DC-energy, which reduces the voltage pressure over the power electronics switching units and undulation is improving execution of the electrical system vitality efficiently and simplifying the circuit nature.

Keywords: Photovoltaic (PV)-Cell; Zero Voltage Switching - (ZVS); Fuzzy Based Fuel-Cell DC-DC Converter-(FBFCDC).

1. Introduction

Vitality Photovoltaic (PV)-Cells are the highly required and demandable energy vitality providers, which are also identified as a important supplement to provide an enhanced renewable sources to electrical units. Now-a-days the problem of pollution overloads and natural improper leadings, requirement is large for fuel-cell based energy sources as a supplement to the present energy providing sources, which is can provide good efficiency with power emissions. Generally vitality Photovoltaic (PV)-Cells are acting as a vitality transforming device, which transforms the Light energy converted to electrical energy and produces the electrical power.

Photovoltaic (PV)-Cells are capable of providing huge power emissions and it can satisfies the essentials of large electrical units acting as power supplement repository. However numerous complications are surrounded with the PV cells in research summary, because there are number of Solar cells available in market and providing energy sources for different mechanisms and each one is operated for different attributes such as temperature', humidity', power balance rate, pressure emission and so on applied capabilities that supports sagacious power management nature. In this system, new electric power supply management system is designed for the solar energy based DC converters, called PV Cell vitality DC-DC Converter [FBFCDC], which effectively manages power source system and performing the DC boost conversion operation over power electronics switching units and undulation. A vitality solar (PV)-cell is a technology, converts solar energy into electrical energy. The majority components used is silicon semiconductors, and combine with photons that generates an vitality electrical voltage. This Photovoltaic cell is used as input to the preferred and existing circuit. In order to decrease the cost instead of FC system we are using PV cell as input.

2. Fuel cell system (FCS)

FCS is bind-up with electro-chemical vitality substance, which transforms the richest hydrogen' fuels into straight electrical vitality with enhanced performance and intelligence. In this transformation, the main concentration or take care is needed in the steps of reducing the heat emission and mechanical activities, as such the traditional methodologies proceed towards, these fuel-cells not supervised by thermal- situations surroundings like the Efficiency.

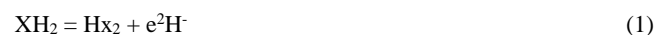

The energy ranges from 1.5v with no loads connected to 3.8v with load connected. With these estimations we can get sustainable electric supply and energy source from the fuel-cell to the converters for further precedence.

3. Zero-voltage switching converter design

The vitality ZeroVoltageSwitching Converters are generally used for transforming the small amount of DC generated power into large amount of DC power response. Generally, the PWM plans to control output voltage operations of the converters. ZeroVoltage Switching strategies are highly improves the vitality generation of the boost converters to minimize the power undulation in output portion. The output generated by the solar-(PV) is 12v DC, which is passing as an input to the Switching DC to DC vitality converter.

The vitality generation of solar array dispatch the power to the loads connected with output circuits and it is maintained for the MPPT technique. The total processing time of controller to perform these operations are lesser than a second, whereas the Sun-irradiation' and the renewable capacities are slightly change at each point of time. This kind of approach is mainly implemented to monitor or track the vitality Photovoltaic Maximum Power Point over periodic changes happened in natural and climate.

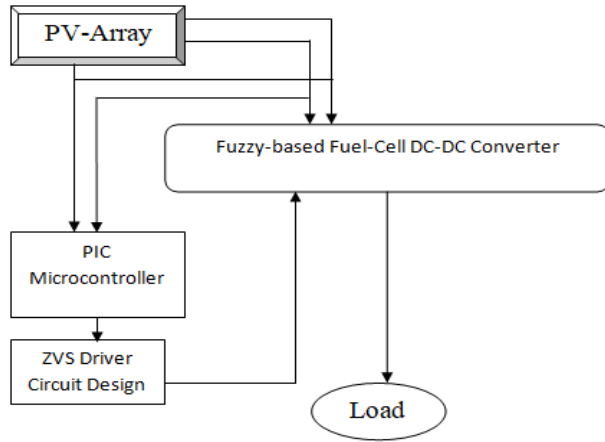

Fig. 1: Block Diagram of FFCDC Based ZVS Converter Design.

The above block diagram clearly explains the output vitality nature of ZVS based FFCDC vitality converter design. The following equations clearly demonstrate the working nature of block diagram and it is used for manipulative vitality analysis.

The attributes of the input vitality source are:

- Input exited voltage (V_i)
- Output response voltage (V_o)
- Switching frequency (F_s)

The L, C, k values are designed using [3]-[5]:

$$D = 1 - (V_s/V_o) \tag{3}$$

$$L = (V_s * K) / (\Delta I * F_s) \tag{4}$$

$$C = (I_A * K) / (\Delta V_C * F_s) \tag{5}$$

Considering the connection between the oxygen' stream and the vitality voltage of the energy unit, by accepting hydrogen stream H_N to be steady. The accompanying Fuel-Cell show is determined to depict the elements between the oxygen stream A_N and voltage C_V vitality.

$$A [Z^{-1}] Y (k) = Z^{-d}.B (Z^{-1})*u^k+W^k \tag{6}$$

$$A [Z^{-1}] = 1 - az^{-1} + a*az^{-2} \dots\dots+anz^{-n} \tag{7}$$

$$B [Z^{-1}] = B_0 + bz^{-1} + b*bz^{-2} \dots\dots+bnz^{-n} \tag{8}$$

Where Z, u, W and B indicates the processing unit's respective input and output samples. W represents the constant power flow, B indicate the alpha and beta values of the vitality power source, Z and U indicates the auto switching unit outputs of the power source system.

$$X (z^{-1}) = [A (z^{-1})] / [B (z^{-1})] \tag{9}$$

Where A (z^{-1}) and B (z^{-1}) indicates the power flow polynomials of the preferred circuit design. According to the cathode Fuel-Cell based Power flow model, the energy flow is derived equation is given as:

$$M = V_{IN} - V_{OUT} \tag{10}$$

Where $F (T^{-1})$ indicates the fuzzy power flow model with time constraint, V indicates the voltage level, u and X are the fluctuation levels of vitality DC-DC converter. The following figure .2 elucidates the Existing circuit diagram as shown below.

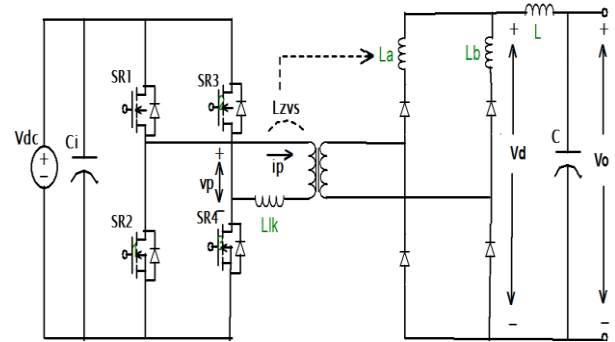

Fig. 2: Existing System Circuit Design.

The following figure.3 elucidates the preferred system's circuit diagram.

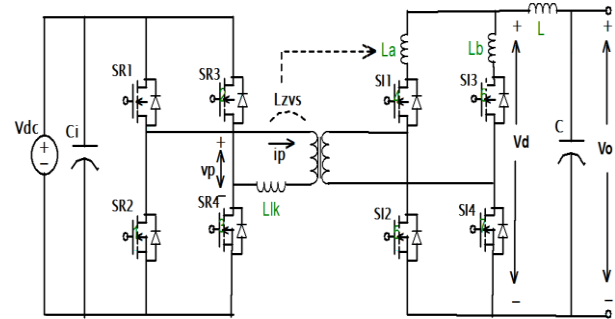

Fig. 3: Preferred System Circuit Diagram.

The preferred system configuration not only improves the usually low solar array voltage, it can also change the generated solar vitality dc of the power which is inserted into quality dc power, is confined as per the IEEE-519. The preferred system topology has best effectual use of the Photo Vatic array, lower cost, high efficiency, and compact. Photovoltaic generation steady-state study, which includes the design expressions and procedure for PWM controlling of the preferred topology has been derived for vitality conduction operation to increase the generation system, is proposed. It consists of vitality dc-dc converters. During power generation vitality, the possibility for preferred system and the forte of the control strategies have been proved by experimental vitality results. All the observations and conclusions, including simulation and experimental result, are presented.

$$P_M = I_o * R_{DS} * \frac{V_o}{V_i} \tag{11}$$

P_M losses in Power MOSFET in a vitality DC-DC converter.. When the integrated high-side MOSFET switched on, the condition of the load current outflow through it. The source drain resistance (R_{DS}) this causes power dissipation. I_o is the current in load from Equation.11.

$$P_C = P_M + P_D + P_I \tag{12}$$

P_C is Conduction loss , P_d is the diode loss, P_i is inductor losses in Equation12.

$$P_T = P_C + P_{LDO} + P_{SW} \tag{13}$$

P_{SW} is the losses in switching and P_{LDO} is the losses in driver and lower dropout losses in Equation 13.

$$\text{Efficiency} = \frac{P_o}{P_o+P_T} \tag{14}$$

P_o is the output response power in equation 14
The preferred vitality system efficiency is better than results compared to existing system that the PV Cell vitality Converter design has a perfect control strategy to revamp the vitality conversion norms more efficiently.

4. Experimental results

Experimental hardware set up

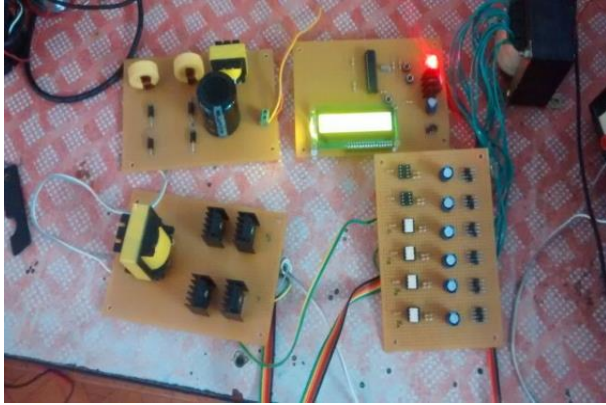

Fig. 4: Hardware Set Up.

5. Experimental hardware setup results waveforms



Fig. 5: Input Voltage.



Fig. 6: MOSFET Voltage.

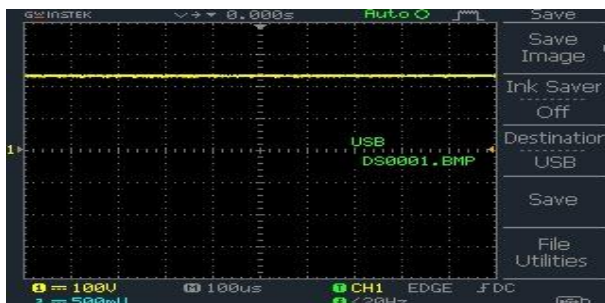

Fig. 7: OUT PUT Voltage.

Its harmonic mitigated compares to the respective harmonic PWM techniques and gets involve in this proposed DC and DC converter.

The widths of the pulses are mitigated at the particular switch by PWM. Due to the mitigation in pulses the ON, state voltage loss at the switching also mitigates.

6. Conclusion

In this preferred system design analysis of Solar cell vitality DC Converter design circuit nature is explored, the performance measures of the PVCDC is clearly demonstrated via graphical results over MATLAB Simulation. The preferred results explored that the PV Cell Converter design has a perfect control strategy that improves conversion norms more efficiently. The Zero-Voltage Switching based circuit and blocks are clearly stated and derived via the mathematical analysis, which provides the proper power conversion with efficient and mitigates the power loss. The main issues raised over the renewable power like Photovoltaic is highly reduced for PV Cell based solar energy converted to electrical energy. For all the entire preferred Soft Switching circuit design is simple in complexity and its performance is more refined with reduced power losses and voltage complications. Furthermore this system can be further extended for Hybrid technology combined both the Circuits in a single Circuit design with maximize the power flow and reduce the complexity with proper strategies as well as with the help of multiple renewable energy sources, power alternative facilities can also be included into the further future work.

References

- [1] Massoud A. M., Abdelsalam A.K., Enjeti P. N. And Ahmed S., (2011) 'High-performance adaptive perturb and study MPPT practice for photovoltaic-based micro grids' IEEE Transaction, vol. 26, no. 4, pp. 1010–1021.
- [2] Borrega M., Lopez J., Agorreta J. L. and Marroyo L., (2001) 'Modelling and organize of N-paralleled grid-connected inverters with LCL filter coupled due to grid impedance in PV plants' IEEE Transaction, vol. 26, no. 3, pp. 770–785.
- [3] Ahmed K. H., Finney S. J., Williams B. W. and Alajmi B. N., (2011) 'Fuzzy logic- control approach of a modified hill-climbing method for maximum power point in micro grid standalone photovoltaic system' IEEE Transaction, vol. 26, no. 4, pp. 1022–1030.
- [4] Shanxu D. Tao C. And Bangyin L., (2011) 'Photovoltaic DC-buildingmodule based BIP system-concept and design considerations' IEEE Transaction, vol. 26, no. 5, pp. 1418–1429.
- [5] Kulkarni S. R., Brunton S. L., Clarkson C. and Rowley C.W., (2010) 'Maximum power point tracking for photovoltaic optimization using ripple-based extremum seeking control' IEEE Transaction, vol. 25, no. 10, pp. 2531–2540.
- [6] Petrone G., Spagnuolo G., Vitelli M. and Femia N., (2005) 'Optimization of perturb an observe maximum power point tracking method' IEEE Transaction, vol. 20, no. 4, pp. 963–973.
- [7] Abido M. A. and Hassan M. A., (2011) 'Optimal design of micro grids in autonomous and grid-connected modes using particle swarm optimization' IEEE Transaction, vol. 26, no. 3, pp. 765–770.
- [8] Saito T., Irisawa K., Sawada Y. and Takano I., (2000) 'Maximum power point tracking control of photovoltaic generation system under non-uniform insolation by means of monitoring cells' Proceedings 28th IEEE Conference proceeding, pp. 1707–1710.
- [9] Agarwal V. and Jain S., (2007) 'A single-stage grid connected inverter topology for solar PV systems with maximum power point tracking' IEEE Transaction, vol. 22, no. 5, pp. 1928–1940.
- [10] Kai S., Yan X., Lanlan F., Li Z. and Hongjuan G., (2011) 'A modular grid connected photovoltaic generation system based on DC bus' IEEE Transaction, vol. 26, no. 2, pp. 523–531.
- [11] A.Sakhare, A.Davari, A.Feliachi, "Control of Stand Alone Oxide Fuel Cell using Fuzzy Logic", In the Proc of the 35th Southeastern Sym on Sys Theory' 2003, pp473-476, March 2003.
- [12] F.Jurado, M.Valverde, "Fuzzy logic inverter flux control of fuel cell plants in distributed generation", 11th Int Conf on Harmonics and Quality of Power, 2004.
- [13] Jurado, M.Valverde, "Novel Inverter Flux Control ForFuel Cell Using Fuzzy Logic", In the Proc of 4th Int Conf on Power Electronic and Motion Control, 2004, vol.2, pp714-718.
- [14] Rosich, V.Puig., J. Quevedo., "Fault-Tolerant Constrained MPC of PEM Fuel Cells", IAR Annual Meeting, 2006, pp1-6.

- [15] J.T.Pukrushpan., A.G.Stefannopoulou., H.Peng. "Control of Fuel Cell Power Systems: Principles, Modelling, and Analysis and Feedback Design", series Advances in Industrial Control, 2004, Springer.
- [16] P.Rodatz. G.Paganelli., A.Sciarretta, L.Guzzella. "Optimal power management of an experimental fuel cell/supercapacitor-powered hybrid vehicle", Control Engineering Practice, 2005, vol.13, pp41-53.
- [17] P.E.M. Almeida., and M.G.Simoes., "Neural optimal control of PEM fuel cells with parametric CMAC networks", IEEE Trans. on Industry Applications, 2005, vol 41(1), pp 237-245.
- [18] Y.El-Sharkh., A.Rahman. M.S.Alam., "Neural networks-based control of active and reactive power of a stand-alone PEM fuel cell plant", J.of Power Sources, 135, pp88-94, 2004.
- [19] C.Bordons., A.Arce., A.J. Del Real., "Constrained Predictive Control Strategies for PEM fuel cells", In the Proc. of ACC'06, ACC, Minnesota, USA, 2006.
- [20] Vahidi. A.G.Stefannopoulou., H.Peng., " Current Management in a Hybrid Fuel Cell Power System: A Model Predictive Control Approach", IEEE Trans. on Control Systems Technology, vol.14(6), 2006.