

Gesture based wireless control for a robotic manipulator

Arockia Vijay Joseph^{1*}, Akshat Mathur², Jatin Verma³, Ankita Singh⁴

¹*Asst. Professor, Department of Electronics and Instrumentation Engineering, SRM Institute of Science and Technology, Chennai, Tamil Nadu.*

²*Department of Electronics and Instrumentation Engineering, SRM Institute of Science and Technology, Chennai, Tamil Nadu.*

³*Department of Electronics and Instrumentation Engineering, SRM Institute of Science and Technology, Chennai, Tamil Nadu.*

⁴*Department of Electronics and Instrumentation Engineering, SRM Institute of Science and Technology, Chennai, Tamil Nadu.*

Abstract

This project plays a very important role to complement the industrial and automation field. Nowadays, robots are used in several fields of engineering and manufacturing and the systems for controlling or actuating them have also enhanced from the past. The use of gestures for controlling them has been the new trend to control the movement of robotic manipulators. The various methodologies for controlling them are motion tracking, image processing and by using Kinect sensors. All these methods can be used as a teach pendant where one can provide the movement of the manipulator as a preset and the manipulator can carry out the same motion repetitively, or in the case of motion tracking and while using Kinect sensors, the user is bound to a confined area where the cameras can monitor the user's body. Here, we propose a wireless controlled robotic arm system for tool handling (pick and place) and many other applications where human reach is elusive. The result is that the gestures of the human hand are in sync with the manipulator's movement. Further, this robotic arm has been implanted beneath a drone which would then have the ability to reach certain heights where human reach is impervious or might put a human's life in jeopardy. In this case, the user can maneuver along with manipulator wherever it is used.

Keywords: Robotic arm, gesture, kinect, motion tracking.

1. Introduction

Robots are widely used in fields of production and manufacturing industries [5], varying in configuration and sizes. Robots have been increasingly integrated into tasks to replace humans to perform repetitive tasks.

Likewise, it is difficult for the worker to carry out tasks which might directly or indirectly affect themselves. For example, performing tasks which require humans to reach heights, diffuse bombs, work near nuclear reactors, etc.

Therefore an independent and mobile robot can replace human tasks.

Therefore a wireless robotic arm is made to ensure it can maneuver long distances and can move in real time according to the motion of our hands.

Incorporating with a drone [1], this arm can be used even at distant heights like on top of a chimney or fix it on top of a mobile ground robot and then it can be used in caves and small underground caverns.

One major purpose will be that this system can be used by disabled people who face difficulties while walking.

They can use this wireless robotic manipulator to carry out periodic chores.

There are several existing models of wirelessly controlled robotic manipulators actuated using machine vision, image processing and even using Kinect sensors [4].

Actuating robotic joints can be achieved by using servo motors, servo motors or pneumatics [2] each having their own pros and cons.

2. Methodology

Gesture control

Gesture control means that the system will imitate the motion of one's body, be it full body or a limb like an arm. This results to exact motion of the robotic arm according to the movement of the hand. Gesture control is easy and unique as well as provides a platform for an individual to know how that system exactly works and also helps understanding much easy. Sensors attached to one's arm acquire the motion of the body and transmit those signals to the receiving end, that is, the robotic arm which further actuates the servo motors in order to move the arm.

Constituents

The robotic arm is made of 3D printing material (ABS) which is incorporated with servo motors to move the joints of the arm. The gesture control system consists of a MPU-6050, flex sensor and an Arduino Nano. The arm joints are fitted with flex sensors, the limbs are fixed with gyroscope and accelerometer sensors [3]. The manipulator is actuated using NI my-Rio as a controller.

3. Proposed design

Overview

The whole system is divided into two parts: one being the hand control system and other being the manipulator control system. Communication between these two systems have been carried out using Xbee protocol. The transmission system is placed on the user's own hand which consists of the hand control board, orientation sensors and flex sensors which provide us with the movement and orientation of the whole hand. The MPU-6050 is an Inertial Measurement Unit consisting of 3-axis gyroscope and a 3-axis accelerometer. The receiving end consists of a control board which processes the data and actuate the servo motors. The control board on the hand consists of an IMU sensor and 2 flex sensors. The IMU will be placed on the upper arm between the shoulder and elbow. One of the flex sensors will be placed on the elbow joint while the other on the fingers. All the sensors are connected to single control board which is placed on the wrist which will also be transmitting the data to the manipulator.

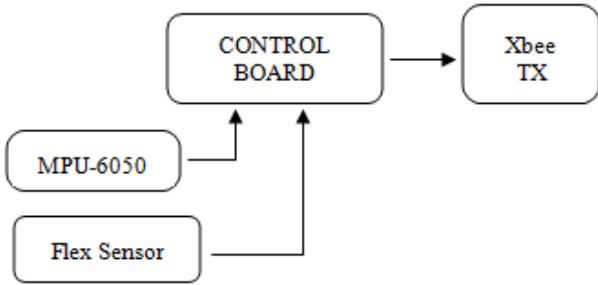

Fig. 1: Block diagram of transmission system

The control board with the manipulator receives the data sent by the hand controller and then NI my-Rio is used to read the data and actuate the servo motors.

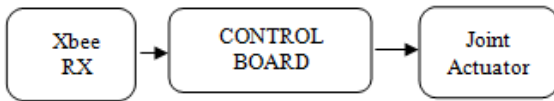

Fig. 2: Block diagram of receiving system

Working

The gesture controlled manipulator mimics the motion of the user's own hand. Sensors are placed on a sleeve which the user will wear. As the hand moves, sensors collect the corresponding angles of the shoulder, elbow and the fingers. The data is collected, processed and then transmitted to the manipulator controller. All the joints have been provided with the minimum and maximum angles within which it functions. A voltage measurement circuit has also been made which will give us the voltage level of the LiPo battery which we are using to power the hand control board.

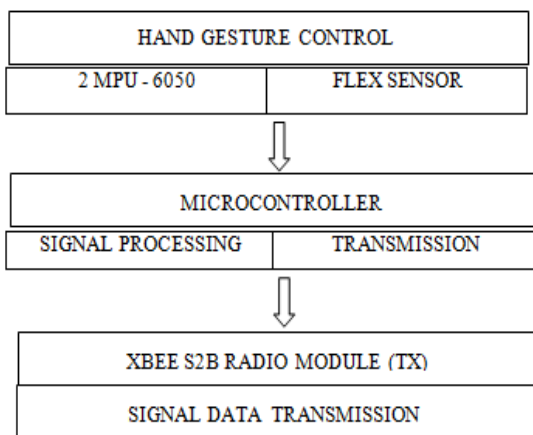

Fig. 3: Signal flow in hand control board

The data received is fetched using NI my-Rio. The serial data received is sorted and processed in LabVIEW hence providing us

with the PWM signals which drive the actuators. The PWM signals generated are mapped with the angular position of the human arm and is then fed to the servo motors in order to actuate them.

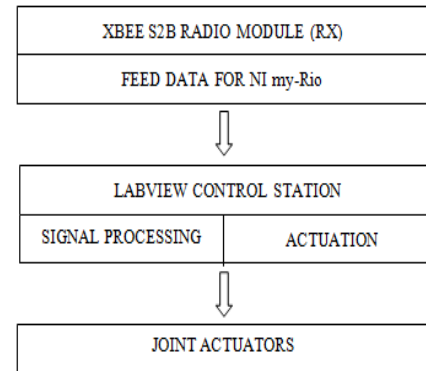

Fig. 4: Signal flow in manipulator control board

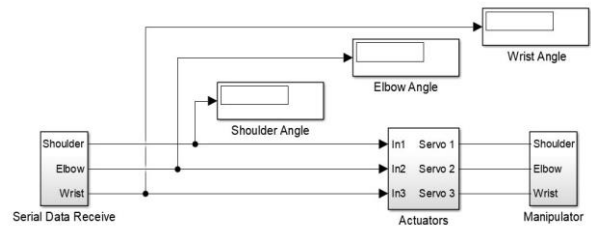

Fig. 5: Simulink model

The servos used are of remarkably high torque, producing a rotational angle of 180°. The Xbee receives data in the form of a string which consists of all the joint angles gathered by the sensors. From this telemetry, the joint angles are extracted and the angular values are converted into duty cycle at constant frequency by using the conversion formula

$$(\theta/18) * 0.01$$

Where θ is the angular value from the gyroscope. The motors have the operating frequency of 50Hz to 330Hz.

Simulation

A CAD model of the robotic manipulator was made in SolidWorks and then it was exported to MATLAB Simulink as shown in Fig. 5. The actuation of the joints were done by providing the inputs from the hand control board. The angular values provided by the sensors were directly fed to the revolute joints of the imported CAD model in Simulink. The inputs provided to the model are real time values of the motion of the user's hand. Through this, we can set the range of angles required for the movement of the actual robotic manipulator and how it will react to the movement of the actual human arm. As the control of the robotic arm is wireless, if it is at a distant place, a camera is mounted on top of it and from the simulation, we can monitor its movement.

In the receiving end, the data read by NI my-Rio is processed in LabVIEW. The data received is in terms of angles from the gyroscope sensor. This is then converted to PWM signals to actuate the servo motors. A dedicated GUI (fig. 6) is also made which indicates all the angular parameters from the gyroscope sensor as well as the voltage levels of the power supply for both the hand and manipulator control boards.

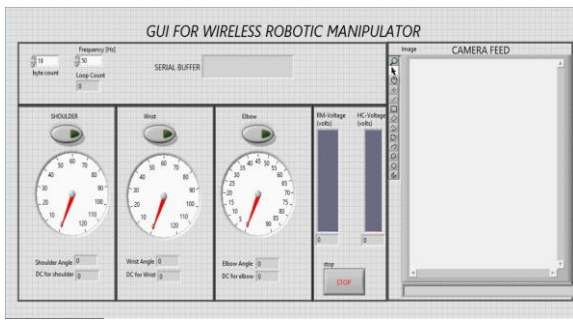

Fig. 6: GUI

Figure displays the GUI formed in LabVIEW providing us with the joint angles, serial data buffer, battery voltage indicators and camera feed.

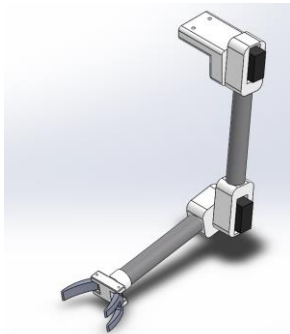

Fig. 7: CAD model of manipulator

4. Calculations

Motor torque

Torque required by the servo motor depends on the payload, weight of the links and the weight of the motors itself. Typically, torque is calculated using the formula,

$$\tau = mg * L$$

Where τ is torque, m is the mass of the load, g is gravity and L is the distance between the payload and the shaft of the servo motor. Suppose Fig. 8 given is a manipulator and we have to calculate the torque τ_1 and τ_2 then, the torque can be calculated by,

$$\tau_1 = L1 * A1 + \frac{1}{2} L1 * W1$$

$$\tau_2 = (L1 + L2)A1 + (\frac{1}{2} L1 + L2)W1 + (L2 * A2 + \frac{1}{2} L2 * W2)$$

Where,

- L1 = length of link 1
- L2 = length of link 2
- A1 = weight of payload
- A2 = weight of servo motor
- W1 = weight of link 1
- W2 = weight of link 2

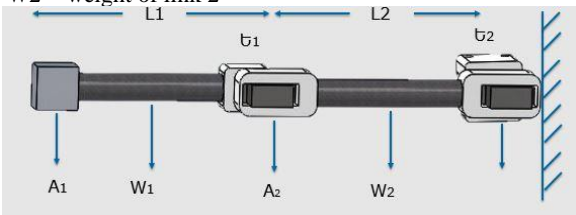
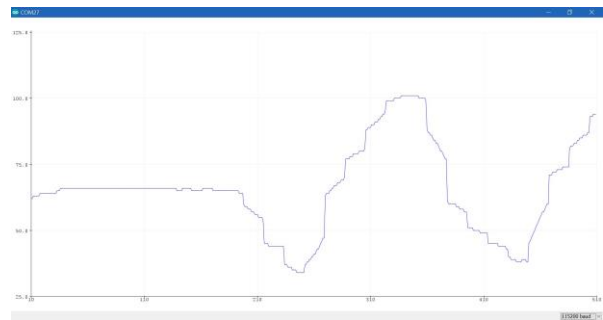

Fig. 8: Manipulator

5. Results

In this project, we used a gyroscope sensor and flex sensors to control and stabilize the movement of the manipulator. The manipulator was actuated by the gestures of the human hand and design and fabrication of the manipulator was completed with economic and effective considerations.

The angular values of the sensors were received and ran through simulations to perceive the actual movement of the manipulator.



(b)

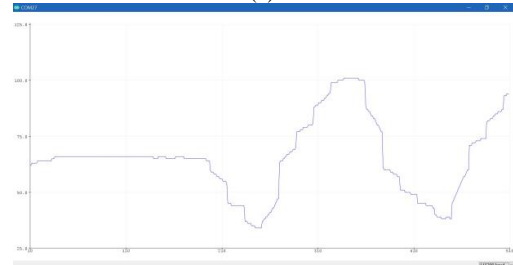

(a)

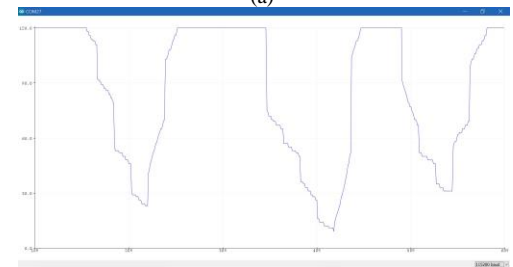

(c)

Fig. 9: Graphs of (a) Shoulder, (b) Wrist and (c) Elbow

The graphs shown in Fig. 9 are the angular values of the sensors placed on the user's hand over a certain period of time. The graphs indicate the angles of limbs with respect to time.

Graph (a) shows the angular movement of the gyroscope placed on the shoulder, graph (b) shows the angular movement of the wrist while graph (c) shows the angular movement of the elbow.

Given a particular time $t=1$ sec, the shoulder is at an angle of 25° elbow at an angle of 120° and the wrist at 60° .

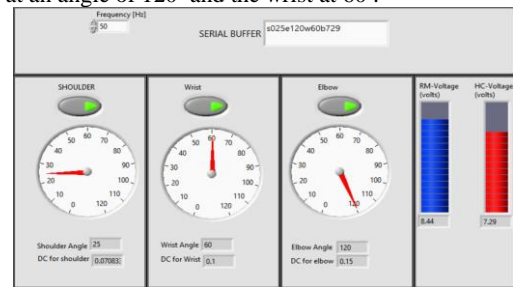

Fig. 10: GUI result

Fig. 10 shows the GUI formed in LabVIEW displaying three dials, two level bars, switches and a serial buffer. The dials display the current angular position of all the sensors. The switches are used to enable or disable that particular joint while in use so that we can lock the arm or joint in that particular position if we want to carry out any task where more precision is required or while carrying objects which should not be disturbed or quivered.

The serial buffer provides the sensor values altogether like "s025e120w60b729" where 's' corresponds to shoulder, 'e' to elbow, 'w' to wrist and 'b' to battery. The blue and red levels corresponds to the voltage levels in the Lipo batteries supplying the hand controller and the manipulator.

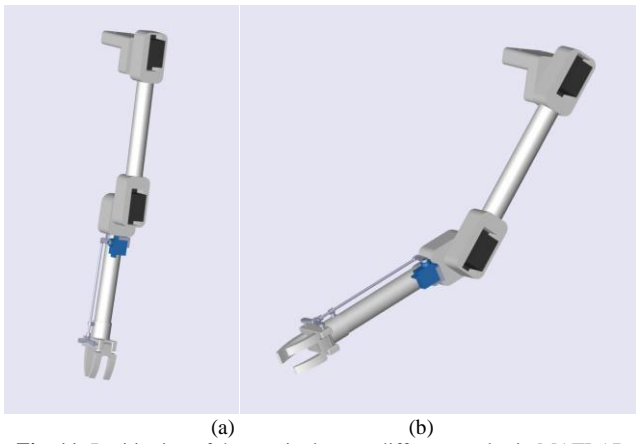

Fig. 11: Positioning of the manipulator at different angles in MATLAB Simulink.

Fig. 11 (a) represents the manipulator whose both shoulder and elbow are at an angle of 0° . This means the user's hand is parallel to the body. Fig. 11 (b) represents the manipulator whose shoulder is at angle of 40° and elbow at an angle of 25° . Hence, the angular values of the sensors were obtained through the user's hand and were transmitted wirelessly to the manipulator which was actuated by giving the sensor values as input.

References

- [1] Arleo G, Caccavale F, Muscio G & Pierri F, "Control of Quadrotor Aerial Vehicles Equipped with a Robotic Arm", *21st Mediterranean Conference on Control & Automation (MED)*, (2013), pp.1174-1180.
- [2] Biswas P & Anandan Shanmugam S, "on Design and Development of a 3 axes Pneumatic Robotic Arm", *International Journal of Advanced Research in Electrical, Electronics and Instrumentation Engineering*, Vol.5, No.9, (2016).
- [3] Ariful IB & Tuton CM, "Gyro-Accelerometer based control of a robotic Arm using AVR Microcontroller", *9th International Forum on Strategic Technology (IFOST)*, (2014).
- [4] Wongphati M, Osawa H & Imai, M, "Gestures for Manually Controlling a Helping Hand Robot", *International Journal of Social Robotics*, Vol.7, No.5, (2015), pp.731-742.
- [5] Ahmed RS, Bodo U & Omar A, "Using Hand Gestures to Interact with an Industrial Robot in a Cooperative Flexible Manufacturing Scenario", *Proceedings of the 3rd International Conference on Mechatronics and Robotics Engineering*, (2017), 11-16.