

Multi-input multi-output converter with battery charger for low power applications

S.Pradeep Kumar^{1*}, R.Krishnakumar¹, E.N.Ganesh²

¹ Assistant Professor, Department of EEE, Vels Institute of Science Technology and advanced studies, Chennai

² Dean, School of Engineering, Vels Institute of Science Technology and advanced studies, Chennai

*Corresponding author E-mail: pradeep88.se@velsuniv.ac.in

Abstract

For low power applications an integrated type multi- input multi- output converter with battery charger was presented in this paper. Power can be delivered from different sources with low power switching device using the proposed topology. The circuit model is designed to reduce the switching losses and to improve the converter overall efficiency by charging the battery using transformer leakage inductance. The input power distribution includes two input sources are operated by this converter model. This paper proposed a 20 –W prototype to test the converter performance and the experimental results are shown.

Keywords: DC Converter; Multiple – Input; Renewable Energy; Battery Charger.

1. Introduction

In modern technology, renewable energy such as solar, wind, tidal and bio-energy have been widely employed on all over the world. The renewable energy generation is not constant due to the atmospheric climatic environment. To overcome this issue, hybrid renewable resources are interconnected to improve the reliability and efficiency of the system. A two-input current- fed full-bridge converter presented in [1], has a feature of soft-switching and can deliver power to the load alone and at the same time. However, it is relatively complicated circuit structure, leading to high cost. To obtain regulated output voltage for different load condition multiple input power sources with different voltage levels and power capacity are combined using multiple input dc-dc converter in [1-3]. In different switching conditions a three level inverter provides smooth output voltage when compared with two level inverter in this paper [4]. A 15-level cascaded multilevel inverter creates the waves based on installed controller using Matlab/ Simulink software in [5]. Total Harmonics Distortion (THD) is reduced to 20.17% with the presence of a filter that removes the reflection phenomena from the simulation results and the matrix converter output is filtered to a pure sine fundamental wave in [6]. A two-input flyback converter in which only one winding is added as well as switching devices are minimized and the design model is simple. However, the voltage stresses on the power switches devices remain high due to the energy stored in leakage-inductor of the transformer, which leads the converter to low efficiency. The converter presented is to recycle energy stored in leakage- inductor to charge battery for stability of the system and improving efficiency of the entire converter [2]. The main aim of this paper is to intend a two-input two-output converter with battery charger for low power applications. The proposed circuit topology has the following advantages:

- 1) The energy stored in leakage-inductor is recycled to charge battery whereas the voltage stress on the main switch can be decreased.

- 2) The converter can efficiently manage suitable power distributed from two input sources.
- 3) The DC input voltage magnitude of this converter is variable with leakage inductance of the transformer.
- 4) The effect of electric isolation can be achieved naturally.

2. Operating techniques

It is an improved version of flyback converter that involves of two sources in the input-stage circuit, a battery charger circuit, a three-winding coupled inductor, and two common sources output-stage circuits. Switches S1 and S2 are used to control power from each input while S3 is used in battery backup mode. The main switch S4 is used to control output voltages. Diodes D1, D2 and D3 are used for bypass current when switches S1, S2 and S3 turn off. The energy stored in leakage-inductor (Llk) that causes a high-voltage spike at switch S4 is recycled to charge battery through the snubber diode (Dsn), the battery filter capacitor (Cbatt) and battery diode (Dbatt). When battery is fully charged, the energy stored in Llk is eliminated by the snubber resistor (Rsn). In secondary sides of transformer, output currents flow to outputs through output diodes Do1 and Do2 and the filter capacitors C1 and C2. The proposed converter has three modes of operation: 1) charging mode; 2) normal mode; 3) backup mode.

The operating methodology and principle are analyzed and discussed as follows. To analyze the steady-state characteristics of the proposed developed converters, some preliminary assumptions are made as:

- 1) All the power switching components are ideal condition.
- 2) The magnetic inductance L_m is sufficiently high, so the current flowing through L_m can be measured as constant.
- 3) The capacitors C1, C2, and C_{batt} are suitably maximum, so the voltages across C1, C2, and C_{batt} can be measured as constant.

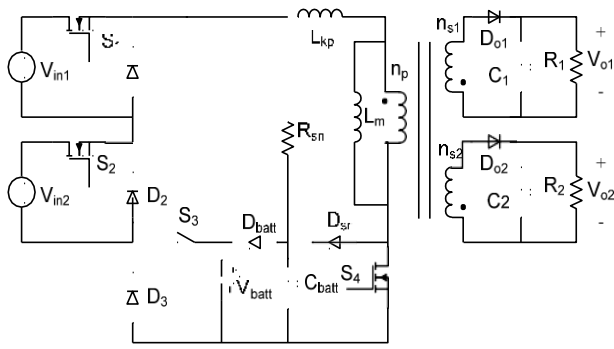

Fig 1: Proposed Model.

2.1. Charging mode

In this charging mode, consider the following switches S1, S2 and S4 are switched ON. The operating description of the converter in different operating intervals is discussed as follows:

2.1.1. Interval 1

During interval 1 (t_0-t_1) Switches S1 and S4 are switched on, while S2 and S3 are switched off. The appropriate equivalent circuit of the converter is shown in Fig. 2(a). In interval 1 the inductors L_m and L_{kp} are charged from the source V_{in1} , so the current flowing through the primary winding is linearly increased. The load currents are provided by output capacitors.

2.1.2. Interval 2

During interval 2 (t_1-t_2) Switches S2 and S4 are switched on, while S1 and S3 are switched off. The appropriate equivalent circuit of the converter is shown in Fig. 2(b). In interval 2 L_m and L_{kp} are charged from the source V_{in2} , the current flowing through the primary winding is still increased linearly. The load currents are provided by output capacitors.

2.1.3. Interval 3

During interval 3 (t_2-t_3) Switches S1, S2 and S4 are switched off. The appropriate equivalent circuit is shown in Fig. 2(c). The energy stored in L_{kp} are released to C_{batt} and battery through D_{sn} and D_{batt} .

2.1.4. Interval 4

During Interval 4 (t_3-t_4) Switches S1, S2 and S4 are switched off. The appropriate equivalent circuit is shown in Fig. 2(d). The energy stored in the inductor of the transformer is released to the load through the secondary winding, and the current of the secondary winding linearly decreases.

2.1.5. Normal mode

The operation of this mode is similar to the charging mode except in interval 2, when battery is full, the energy stored in L_{kp} will be released to C_{batt} and R_{sn} . The appropriate equivalent circuit is shown in Fig. 2(e).

2.1.6. Backup mode

In this mode, only S3 is conducting. The operation of this mode is as the flyback converter. The appropriate equivalent circuit is shown in Fig. 2(f).

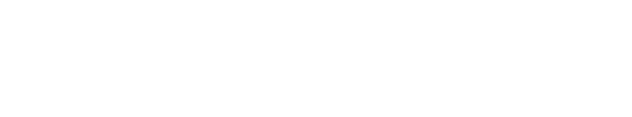
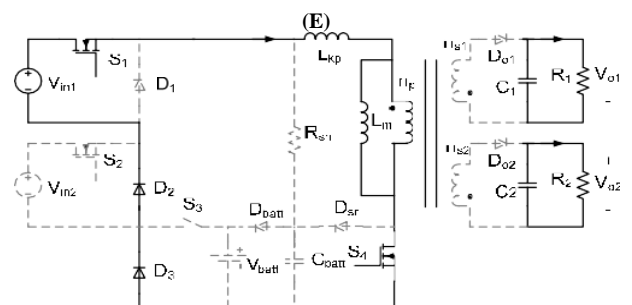
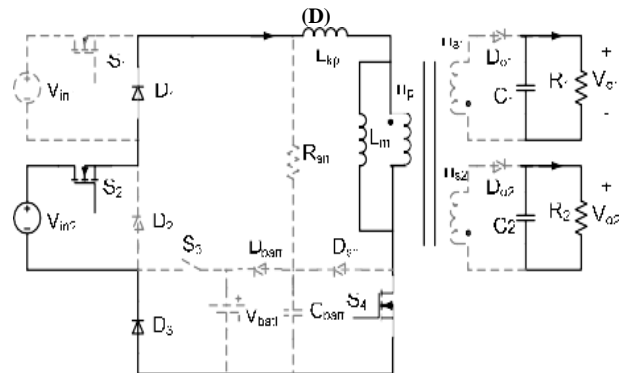
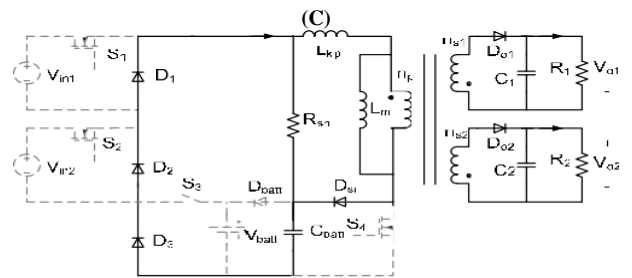
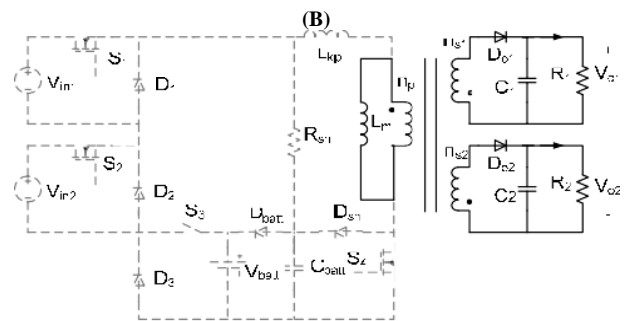
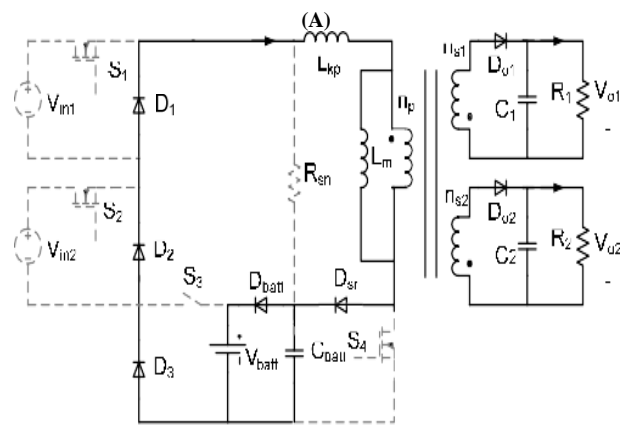

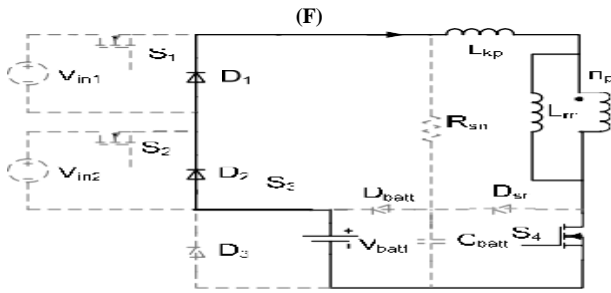

Fig. 2: Equivalent Circuits of Different Operation Modes.

3. Theoretical analysis

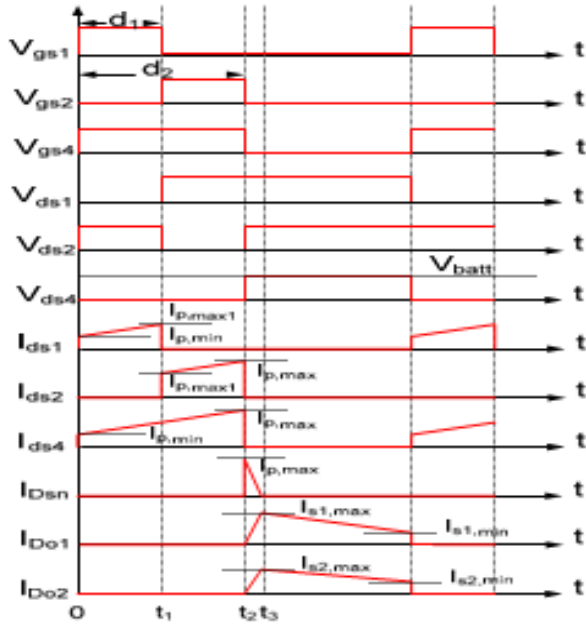

Fig. 3: Waveforms of the Proposed Converter.

Fig 3 gives the key waveforms for the proposed converter in charging and normal modes, which are similar in the operation. Under continuous current mode, V_{gs1} , V_{gs2} and V_{gs3} are the driving signals of switches $S1, S2$ and $S4$, respectively. V_{ds1}, V_{ds2} and V_{ds3} are the drain-source voltages across $S1, S2$ and $S4$, respectively. I_{ds1}, I_{ds2} and I_{ds4} are the currents through $S1, S2$ and $S4$, respectively. I_{Dsn} is the current flowing through the snubber diode. I_{Do1} and I_{Do2} are the currents of the output diodes $Do1$ and $Do2$ respectively. $I_{p,max}$ and $I_{p,min}$ are the maximum and minimum values of the primary winding current of the transformer. $I_{s,max}$ and $I_{s,min}$ are the maximum and minimum values of the secondary winding current of the transformer. $I_{p,max1}$ is the maximum value of the current flowing through $S1$. To analyze the relationship between the input and output voltages and between the input and output currents, the leakage inductor of the transformer is neglected.

4. Experimental results

A 20-W multiple-input multiple-output prototype is built to prove the circuit operation with 2 inputs, 2 outputs and a battery charger.

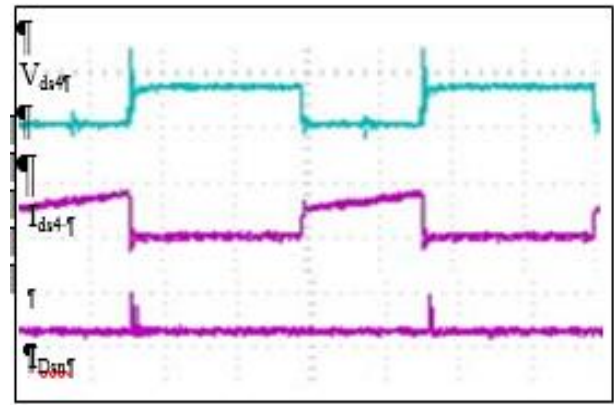

Fig. 5: Waveforms in Charging Mode of the Proposed Converter.

For charging mode in Fig.5, we can see that the current flows through diode D_{sn} to charge the battery, meanwhile voltage stress on switch $S4$ is decreased, leading to better efficiency. Fig.6 and Fig.7 show the overall efficiency of the converter when one of input voltage V_{in} is varied and fixed the other at rated. Fig.6 shows the efficiency when the converter runs in backup mode.

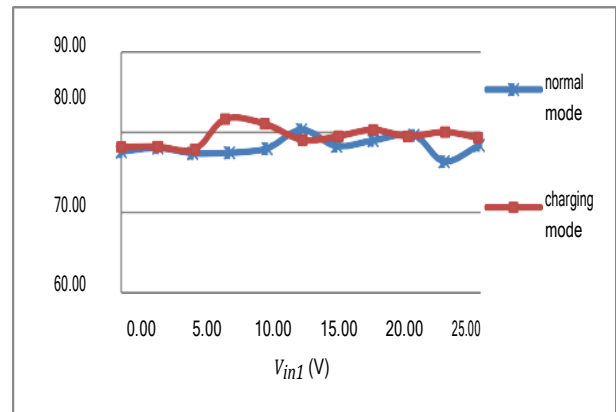

Fig. 6: V_{in1} Is Varied and V_{in2} Is Fixed at Rated.

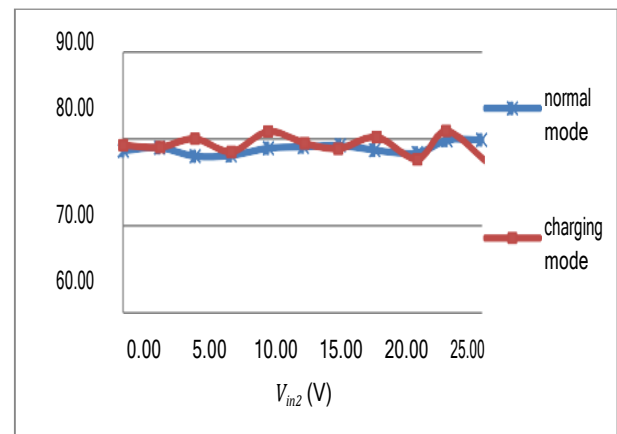

Fig. 7: V_{in2} Is Varied and V_{in1} Is Fixed At Rated.

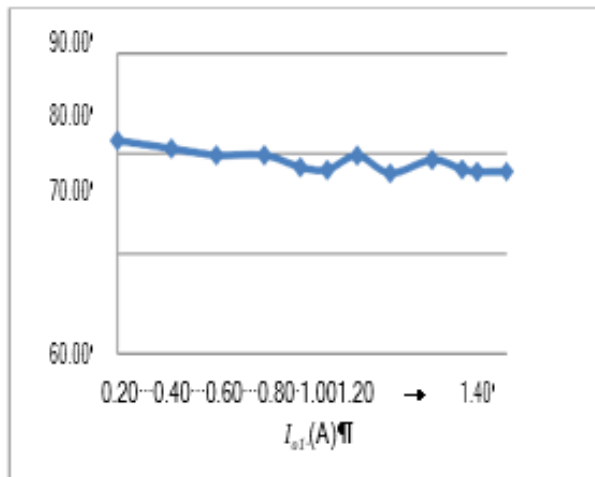

Fig. 8: Backup Mode, V_{batt} Is Fixed At Rated.

5. Conclusion

This paper proposed and discussed on multiple-input multiple-output converter with 20- W battery charging techniques used for low power applications. The four different operating intervals of the proposed converter were presented. In charging mode to charge the battery the current flows through diode D_{sn} , meanwhile voltage stress on switch S_{ais} is decreased, leading to better efficiency. This paper contributes the energy stored in leakage-inductor is used for charging the battery and the proposed converter control strategies is applicable for power distribution by two input sources. Experimental results are analyzed and verified to prove the performance and efficiency of the proposed converter.

References

- [1] Chen, Y. C. Liu, and F. Y. Wu, "Multi-input DC/DC converter based on the multi-winding transformer for renewable energy applications," *IEEE Trans. on Ind. Appl.*, vol. 38, no.4, pp.1096-1104. Aug.2002.
- [2] Q. Wang, J. Zhang, X. Ruan, and K. Jin. "A Double- Input Flyback DC/DC Converter with Single Primary Winding" *Energy Conversion Congress and Exposition, IEEE, 2010*, pp.1938-1944.
- [3] Qian ZJ, Abdel-Rahman O and Batarseh I. "An Integrated Four-Port DC/DC Converter for Renewable Energy Applications," *IEEE Trans. Power Electron.*, vol. 25, no: 7, pp. 1877-1887, Jul.2010.
- [4] N. Shanmugasundaram and S. Thangavel, "Modeling and Simulation Analysis of Power Cable aThree Level Inverter Fed Induction Motor Drive", *Journal of Computational and Theoretical Nanoscience*, Vol. 14, 972–978, 2017.
- [5] K.K.Saravanan and Dr. N. Stalin, "Design of three Phase Fifteen level cascaded Multilevel Inverter Using Embedded Controller ", *International Journal of Applied Engineering Research*, ISSN 0973-4562 Vol.10 No.72 (2015).
- [6] N. Shanmugasundaram and R. Vajubunnisa Begum, "Modeling and Simulation Analysis of Power Cables for a Matrix Converter Fed Induction Motor Drive (MCIMD), *Jour of Adv Research in Dynamical & Control Systems*, 11-Special Issue, November 2017.