

Automatic Synchronverter: Inverter Lacking a Devoted Synchronization Unit

S. Manoj *, S. Pradeep Kumar, N. Ashok Babu

¹Assistant Professor, Vels Institute of Science Technology and advanced studies, Chennai

*Email: manoj.se@velsuniv.ac.in

Abstract

The design of self-synchronized synchronverter is made by removing the keen synchronization unit. Synchronization with the grid takes place before connection and it will track the grid frequency after connection. Like the original synchronverter it functions in various modes to deliver the grid frequency as the reference frequency. The functions of frequency regulation, voltage regulation, real and reactive power control are maintained. Moreover, it can share the real power and reactive power accurately. Distributed energy sources delivers the major contribution to the power system operation. Generally the renewable sources are non-linear and uncontainable. Majority of renewable energy sources were associated to power systems through dc/ac converters. For this kind of application synchronizing the inverter with the grid is necessary before and after the connections to be made. It is one of the biggest challenges. So synchronverter is designed to deliver a scheme for power systems to regulate the renewable energy connected to the grid and enables smart grid integration.

Keywords: Distributed Generator, Point of Common Coupling, Pulse Width Modulation, Renewable Energy Source and Synchronous Generator.

1. Introduction

Study of current regulation in the power converters has been one of the major demanding activities in recent times. The Zero Steady state error is protected by the usage of proportional integral (PI) controller while the reference current is a direct signal which is as same as dc motor drive [1]. Whereas, if the reference current signal is as same as ac motor drive then the direct utilization of PI controller would lead to finite gain at operating frequency. Then a synchronous mounted PI controller was recommended which promises a zero steady-state error in a balanced system.

Digital insight of the comprehensive integrators and the compensation of the delay are studied with the scheming of PI constants. The instantaneous reactive power theory will be used for reference current generation. The difficulty in this theory associated to non-ideal point of common coupling (PCC) voltage will be determined by the sequence filter.

Electrical grid is continually stressed with difficulties related to the voltage instability. In recent times, this problem has turn into significantly severe as the conventional electrical setup is ranging. Up-rising of electrical system has been taking place ever since the Distributed Generator (DG) and Renewable Energy Sources (RES) is introduced in the electrical grid [2]. Integration of several tools pointed towards the increasing diversity of grid, comprising of smart grids drives more restraining standards. Limitations in RES and DG power quality are known in every countries in so termed "grid codes"[3]. Various control schemes based on synchronverter for the HVDC transmission by emulating control of synchronous machine on both sending and receiving ends. The self-regulating VSC technique offers control of active and reactive power[4][5]. In power network, to facilitate the quality analysis numerous devices

were developed to improve the quality of electricity[6]. Also the harmonics exist in the motor terminal due to the increase in voltage is reduced by adding the filter to the load terminal by eliminating the reflecting voltage, as the modelling of voltage waveform at various stages are measured and developed the power cable screen input[7][8]. To enhance the voltage using high step-up DC-DC coupled converter, losses and ripples are reduced to produce high output voltage implied in the PWM technique in the inverter circuit [9].

2. Proposed System

In proposed system, the ability of synchronizing with the grid is enhanced by means of the Synchronverter strategy. As the strategy shown in Table 2.1 in the closed loop system this strategy will remove the slow element. It consists of synchronization unit, inverter controller and the power system. It prevents speed and accuracy of synchronization by eliminating major nonlinear elements.

A current controller is excluded there but for over current protection it can be included. In the regulation of system voltage and frequency, the DG and grid connected renewable energy.

2.1. Self Synchronverter

It is possible to integrate the synchronization functions into the power controller and make synchronize with the grid. In this paper, a essential step is taken by inserting the synchronization function into the power controller as per the removal of synchronization unit as per the grid connected inverter control structure shown in figure 2.1. This will make the system operation at ease by removing a non-linear element from the system.

Table. 2.1. Modes of Operation for Self-Synchronized Synchronverter

Switch S _c	Switch S _p	Switch S _o	Mode
1	ON	ON	N/A
1	ON	OFF	Self – synchronization
1	OFF	ON	N/A
1	OFF	OFF	N/A
2	ON	ON	P-Mode, Q _D -Mode
2	ON	OFF	P-Mode, Q-Mode
2	OFF	ON	P _D -Mode, Q _D -Mode
2	OFF	OFF	P _D -Mode, Q-Mode

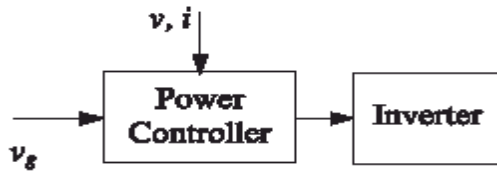

Fig. 2.1 control scheme of grid-connected inverter

The adjacent effort laterally this course is where an supplementary PLL is not required in the course of normal operation but a backup PLL is still required for synchronization before connecting to the grid [8]-[12]. Synchronverter consists of a power part as shown in figure 2.2.

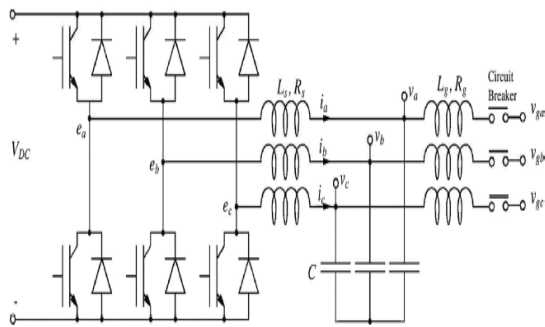

Fig.2.2 Power part of a synchronverter

The control performance and the system stability could be A slow synchronization unit could directly affected right away by slow synchronization unit, on the other hand, complex synchronization unit supplements computation problem to the controller[13][14]. As the DC bus bar volatge of the synchronverter is supposed to be constant. Else, DC bus bar voltage is maintained constant by connecting a dc-bus voltage controller, together with an energy storage system, so that the either synchronverter’s reference real power or in and out power flow of the energy storage system is regulated.

2.2. Synchronverter Control

As the Electronic representation of the synchronverter shown in Figure 2.3 suggests that the scientific model of a three-phase wound rotor synchronous machine is included which is termed by

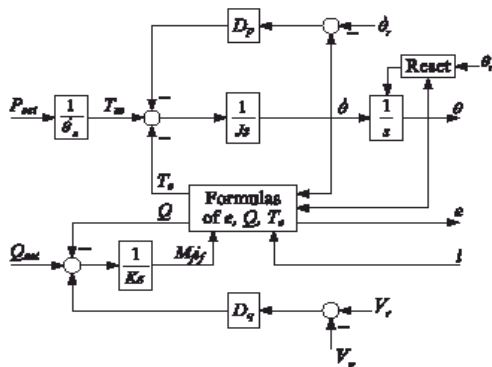

Fig.2.3 Electronic representation of a synchronverter

$$\theta = \frac{1}{J} (T_m - T_e - D_p \theta) \tag{2.1}$$

$$T_e = M_f i_f (i_g \sin \theta) \tag{2.2}$$

$$e = \theta M_f i_f \sin \theta \tag{2.3}$$

$$Q = \theta M_f i_f (i_g \cos \theta) \tag{2.4}$$

Where T_m is the functional mechanical torque of the rotor, T_e represents the electromagnetic torque, e is the generated three-phase voltage and Q is the reactive power. J is the imaginary moment of inertia of all the parts rotating with the rotor. i_f is the field excitation current and M_f is the maximum mutual inductance between the stator windings and the field winding. Frequency of the switching signal e is directed to the Pulse Width Modulation (PWM) Generator and I is the stator current supplied out of the machine.

$$\sin \tilde{\theta} = \begin{bmatrix} \sin \left(\theta - \frac{2\pi}{3} \right) \\ \sin \left(\theta + \frac{2\pi}{3} \right) \end{bmatrix}$$

$$\cos \tilde{\theta} = \begin{bmatrix} \cos \left(\theta - \frac{2\pi}{3} \right) \\ \cos \left(\theta + \frac{2\pi}{3} \right) \end{bmatrix}$$

In this paper, it is presumed for each phase the quantity of pole pairs is one and therefore the machines mechanical speed is equivalent to the electrical speed of the electromagnetic field.

Corresponding to the regulation of a synchronous generator, the synchronverter controller has the provision of two channels for both real and reactive power control. This loop sets the speed $\dot{\theta}$ of the synchronous machine which forms the phase angle θ for the control signal e . Where D_q is the voltage droop coefficient, controls the reactive power. This loop controls the field excitation $M_f i_f$ and makes the proportionality to the magnitude of the voltage generated. Henceforth, the frequency, voltage, real power and reactive power controls are incorporated in one compact controller with merely four parameters.

The grid information is provided by the synchronization unit for the synchronverter to synchronize with the grid before connection and to supply the preferred real and reactive powers after connection[15].

2.3. Synchronous converter to an Infinite Bus

The per-phase model synchronverter, connected to an infinite bus is shown in fig 2.4

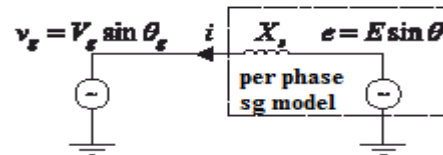

Fig.2.4 The per-phase model of an SG connected to an infinite bus

The generated real power P and reactive power Q are,

$$P = \frac{3V_g E}{2X_m} \sin(\theta - \theta_g)$$

and,

$$Q = \frac{3V_g E}{2X_s} [E \cos(\theta - \theta_g) - V_g]$$

where V_g be the infinite bus voltage amplitude, E is the amplitude of generated voltage of the SG regulated by means of exciting voltage or current and M_f in the case of a synchronverter; θ_g is the grid

voltage phase and θ represents the phase angle of SG respectively and the synchronous reactance is represented as X_s .

$$\delta = (\theta - \theta_g)$$

The driving Torque of the turbine controls the phase difference which is also known as the power angle. As the parameters V_g and E are amplitude values and the factor here is $1/2$.

By increasing the driving torque T_m , the phase angle δ rises and sequentially the real power delivering through the grid gets increased up to the mechanical power from the turbine is identical to that of the electrical power supplied. $\pi/2$ rad is the value at which the generator gets to synchronize with the grid at the maximum δ . when the increase in mechanical power occurs then it impacts in a phase angle that is greater than $\pi/2$ rad, then the synchronization between the rotor of SG with the grid drops and this should be avoided.

$$E = V_g$$

$$\theta = \theta_g$$

3. Test System

The test system is modeled in MatlabR2010 software. Automatic Synchronverter Inverters lacking a Devoted Synchronization Unit was modeled by its components in the MATLAB software to make more real simulation results.

3.1. Simulation Model

As the self-synchronized synchronverter has been proposed, implemented, and verified. So, for the synchronization purpose, incorporating the dedicated synchronization unit is not needed. The mathematical model of SG is considered to be the primary part of the controller. The addition of the mathematical model of a three-phase cylindrical rotor synchronous machine in the controller.

The Frequency and voltage droop control loop controls the real and reactive power respectively. In the proposed synchronverter system some changes have been made in the core of the controller so that, it can be coupled to the grid securely and to run without the requirement of the devoted synchronization unit.

A power inverter is an electronic device or electrical system that converts the Direct Current to Alternating Current.

The filter can produce calculative cost saving while the preset distortion level is attained. Minor loss, reduction in size and weight in accordance to the capacity are standard filters. Circuit breaker is an autonomously functioned electrical switch intended to protect an electrical circuit from faults affected by overload or short circuit. Its simple purpose is to identify the fault condition and break the current flow. MCB used in low application to control and protect the electric circuits may not have enough interrupting ability these circuit breakers are named "supplemental circuit protectors".

4. Simulation Results

This system was modeled in MatlabR2010 software. Also, the Automatic Synchronverter Inverters lacking a Devoted Synchronization Unit was modeled by its components in the Mat lab software to make more real simulation results.

4.1. Grid Voltage

Two simulation were processed under the grid fault conditions in the self-synchronized Synchronverter. Those two conditions persists when the voltage dip in grid is 50% and other for the frequency One is when the grid had a 50%voltage dip drop in the grid is 1%. Apart from these, the impedance of the feeder is also considered under normal operating condition.

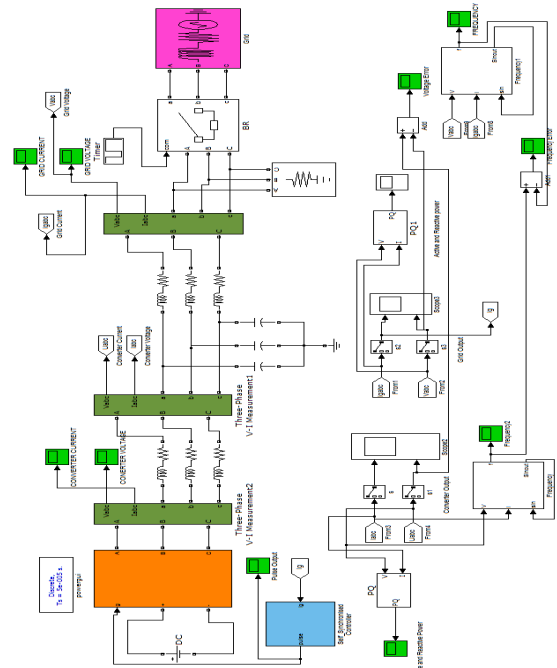

Fig. 3.1 Proposed Simulation circuit

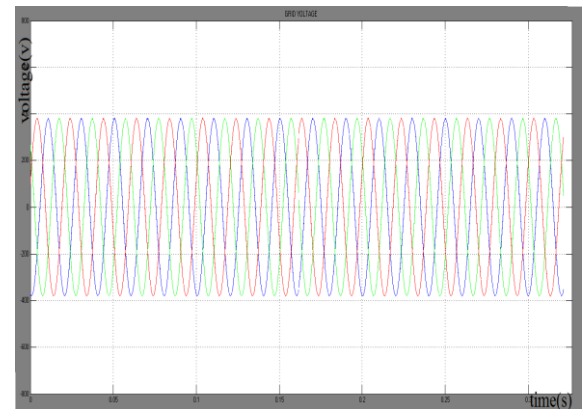

Fig: 4.1 Plot for the output waveform of grid voltage

4.2 Real and Reactive Power

The real power and reactive power were monitored with the set reference points. The real power shown in figure 4.2 was the actual power which was comparatively less than the reference point supplied from the synchronverter to the grid, due to the small loss in the internal resistance of the inductor. The real power will rise to the new steady state condition, When the PD -mode is enabled.

The reactive power value raised about 40 VAR due to the low grid voltage and makes the generated reactive power response smooth and stable. Due to this and the frequency tracking impacts in the real and reactive power with small ripples. From this sort of control the performance of both real and reactive power control very significant and the efficacy has been increased by about 83% and 70% respectively.

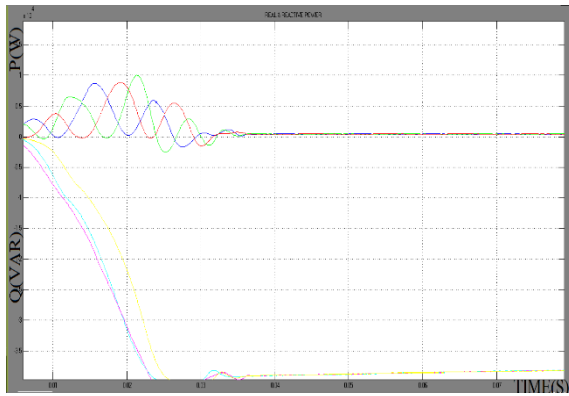

Fig: 4.2 Plot for the output waveform of Real and Reactive Powers

4.3 Voltage Error

As suggested in the grid voltage under the grid fault conditions of voltage dip and frequency drop. The impedance of the feeder can be considered as 0.405Ω and 1.35mH .

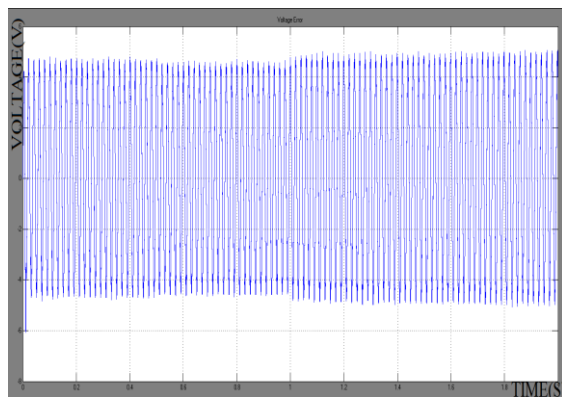

Fig: 4.3 Plot for the output waveform of voltage Error

The output voltage reduced and recovered according to the existing and clearing of fault. While the response time taken by the frequency return back to normal state is 0.2 s , where the voltage and current response time taken is 0.1 s after the fault is eliminated. For safety reasons, this was demonstrated and compared with a low-power low voltage system. Though the working model is adequate to low voltage and power levels and it can also be definitely mounted up for high power and high voltage applications.

4.4. Frequency Error

The results of the frequency response is shown in Figure 5.4 when the grid frequency is lesser than 50 Hz , the synchronverter track the grid frequency perfectly earlier the connection to the grid with accomplished peak ripples of about 0.0053 Hz . As the performance of the frequency tracking is significantly improved by the self-synchronized synchronverter with the existence of smallest ripple when the frequency value exceeds 0.035 Hz .

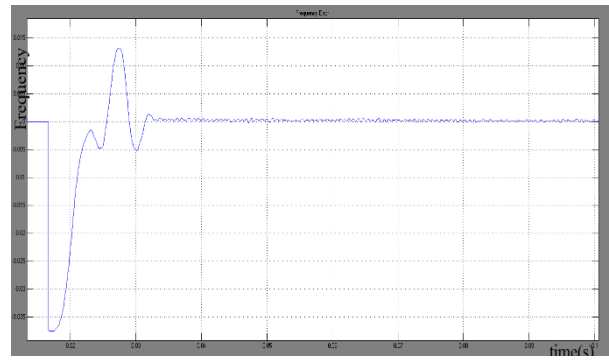

Fig: 4.4 Plot for the output waveform of frequency Error

Similarly the frequency response when the grid frequency increasing 50 Hz . It results with negligible difference in response comparing to the response with the enabling of droop modes. The fine frequency tracking and the set reference for real power and reactive power were trailed with even changeover and slight overreaches. The real power will rise to the new steady state condition, When the PD -mode is enabled.

5. Conclusion

A self-synchronized synchronverter is proposed, implemented, and verified without the requirement of the devoted synchronization unit for the purpose of synchronization. This enhance the system performance with basic controller, lesser mandate for calculative power, moderated development cost with less work, and better software consistency. Synchronization takes place earlier the connection to the grid and it will evaluate the grid frequency later connection. Furthermore, it can work in various modes as the conventional synchronverter with short of the requirement of the devoted synchronization unit to offer the grid frequency identical as the reference frequency. Mathematical outcome presents the proposed control approach can enhance the frequency tracking performance greater, similarly the performance of real power control is improved to 83% , and reactive power control to 70% . Main aim of this paper is to determine the possibility of eliminating the synchronization unit which is considered as the essential part for grid-connected inverters. Whether it might prolong to further kinds of controllers for grid-connected inverters is a demand. In standard, if a controller is able to synchronize, then the controller can possibly make the synchronization unit eliminate.

References

- [1] Xiomng Yuan, Merk W, Stemmler H, Allmeling J "Stationary-frame generalized integrators for current control of active power filters with zero steady-state error for current harmonics of concern under unbalanced and distorted operating conditions" *IEEE Trans. Ind. Appl.* Vol. 38, pp523 - 532, Mar/Apr 2002.
- [2] Zhong Q. C., and Weiss G.(2009) 'Static synchronous generators for distributed generation and renewable energy', *Power Syst. Conf. Exhib. IEEE PES.*, pp. 1-6.
- [3] Zhong Q. C., and Weiss G.(2011) 'Synchronverter: Inverters that the Mimic synchronous generators', *IEEE Trans. Ind. Electron.*, vol. 58, No. 4, pp. 1259-1267.
- [4] Svensson J.(2001) 'Synchronization methods for grid-connected Voltage source converter', *IEE Proc. Generat., Transmiss. Distrib.* vol. 148, no. 3, pp. 229-235.
- [5] Raouia Aouini Bogdan Marinescu Khadija Ben Kilani Mohammed Elleuch "Synchronverter-Based Emulation and Control of HVDC Transmission" *IEEE Trans. Power Systems* vol. 31 no. 1 pp. 278-286 Jan. 2016.
- [6] Shanmugasundaram N Vajubunnisa Begum R Ganesh N "Measurement and detection of voltage dips and swells in power circuits" *International Journal of Engineering & Technology*, 7 (2.8), 239-242, 2018.
- [7] Shanmugasundaram N Vajubunnisa Begum R "Modeling and Simulation Analysis of Power Cables for a Matrix Converter Fed

- Induction Motor Drive (MCIMD)” *Jour of Adv Research in Dynamical & Control Systems*, 11-Special Issue, November 2017.
- [8] Shanmugasundaram N Thangavel S “Modeling and Simulation Analysis of Power Cable a Three Level Inverter Fed Induction Motor Drive” *Jour of Comput. Theor. Nanosci.* Vol. 14, 972–978, 2017.
- [9] Saravanan K K Elankurisil S A “Analysis an investigation on photo voltaic system Stability for Grid connected Load” *Journal of Electrical Engineering*, Vol. 17,2017.
- [10] Ciobotaru M., Teodorescu R., and Blaabjerg F.(2006) ‘A new single-phase PLL structure based on second order generalized integrator’, in Proc. 37th IEEE *Power Electron. Spec. Conf.*, pp. 1–6.
- [11] Rodriguez P., Pou J., Bergas J., Candela J., Burgos R., and Boroyevich D.(2007) ‘Decoupled double synchronous reference frame PLL for power converters control’, *IEEE Trans. Power Electron.*, vol. 22, no. 2, pp. 584–592.
- [12] Singh B., Saha R., Chandra A., and Al-Haddad K.(2009) ‘Static synchronous compensators (STATCOM): A review’, *IET Power Electron.*, vol. 2, no. 4, pp. 297–324.
- [13] Singh B., Saha R., Zhang Q., D-Sun X., Zhong Y.R., Matsui M., and Ren B.Y.(2011) ‘Analysis and design of a digital phase-locked loop for single-phase grid-connected power conversion systems’, *IEEE Trans. Ind. Electron.*, vol. 58, no. 8, pp. 3581–3592.
- [14] Thacker T., Boroyevich D., Burgos R., and Wang F.(2011) ‘PLL noise reduction via phase detector implementation for Single-phase systems’, *IEEE Trans. Ind. Electron.*, vol. 58, no. 6, pp. 2482–2490.
- [15] Midtsund T, Suul J. A, Undeland T "Evaluation of current controller performance and stability for voltage source converters connected to a weak grid"Proc. 2nd IEEE *Int. Symp. Power Electron. Distrib. Gener. Syst.* pp. 382-388 Jun. 2010.
- [16] Harnefors L, Bongiorno M, Lundberg S. "Input-admittance calculation and shaping for controlled voltage-source converters"IEEE *Trans. Ind. Electron.* vol. 54 no. 6 pp. 3323-3334 Dec. 2007.
- [17] Zhang L., Harnefors L., and Nee H. P.(2010) ‘Power-Synchronization control of grid-connected voltage-source converters’, *IEEE Trans. Power Syst.*, vol. 25, no. 2, pp. 809–820.