



Treatment for Scoliosis Using Pneumatic Control System

A. Mohana Lakshmi^{1*}, Sharon Jofiny², P.Sindhuja³, G.V.Jason Jebasingh⁴, B. Suresh Chander Kapali⁵

^{1, 2, 3} Students, Alpha College of Engineering, Department of Bio Medical Engineering, Chennai

^{4, 5} Assistant Professor, Alpha College of Engineering, Department of Bio Medical Engineering, Chennai

*Corresponding Author Email: monjusastiathi@gmail.com

Abstract

Now a day's curvature of spine is a common problem from babies to adults. In this paper, a wearable brace is used to provide patient to overcome from scoliosis by wearing braces with controlled pressure. Scoliosis is one of the spine diseases, the spine will be in S shape or C shape, in some degree of curve. But mostly occurs in Juvenile stage (3-10 years) and also women face this problem. It can be cured by a proper treatment by wearing a brace. The pressure control system is microcontroller. Bracing is a common non-surgical treatment for scoliosis, more often the patient wear their braces to the prescribed tightness. It works by applying corrective pressure on the outer side of curve and cutting out respective areas of relief to inner side of curve, so the spine can migrate in that direction. The pressure control device was developed to understand brace wear time and regulate a target pressure range. The pressured data is transmitted to the central processing station. The effectiveness of our system is to monitor the development of posture of spine by wearing braces with controlled pressure.

1. Introduction

The spine is located in centrally and posterior in the body which protects our spinal cords and bears the body. The spine begins from the base of the skull to the pelvis, the spine is necessary to our body because it provides the structure, flexibility, support and movement. Scoliosis is a common medical condition in which a person's spinal has three dimensional deformity. Scoliosis that develops at the age 10. It occurs eight times more frequently in females than in male. The general method to treat scoliosis is the use of material brace which forces the patient mechanically to hold in corrective posture to prevent further deformity. In this work, we used this project to provide a cost effective way to treat scoliosis, it hopes the patient to overcome from scoliosis by wearing braces with controlled pressure to achieve the system to give regulated pressure to the patient through braces worn. This system consists of body mounted sensor and portable data processing. A specified pressure is given the the air bladder through a pump using valve and by pressure sensor the data is logged in central processing station. The pressure sensor and controller is placed on the brace wall. This device consist of two part such as sensing part and controlling part. Thus, this paper is about treatment for the spinal curvature to provide early corrective measures.

pressure was logged with the capacity to store up to one year of samples in 3MB[1]. The pump and valve operation is suspended at to avoid waking the patient. Without the pressure and wear time, no meaningful conclusion about brace effectiveness. Technology has been applied to solve this problem by temperature sensors[3], force sensors[4] have been used to monitor brace pressure. This paper reports on the development of a system regulates pressure by presenting minimal convenience to the patient.

2. Existing Method

The existing method consist samples with eight pressure taken over 1s. This helps to reduce the breathing effect while taking measurement. In our test the breathing test can cause 30% error over 8 minutes pressure reading. The average of the eight pressure sample is passed to a feed back network consisting of an exponential average value. The desired pressure is maintained within a specified tolerance by inflating or deflating the air bladder. If necessary additional pressure sample is added. The

3. Block Diagram

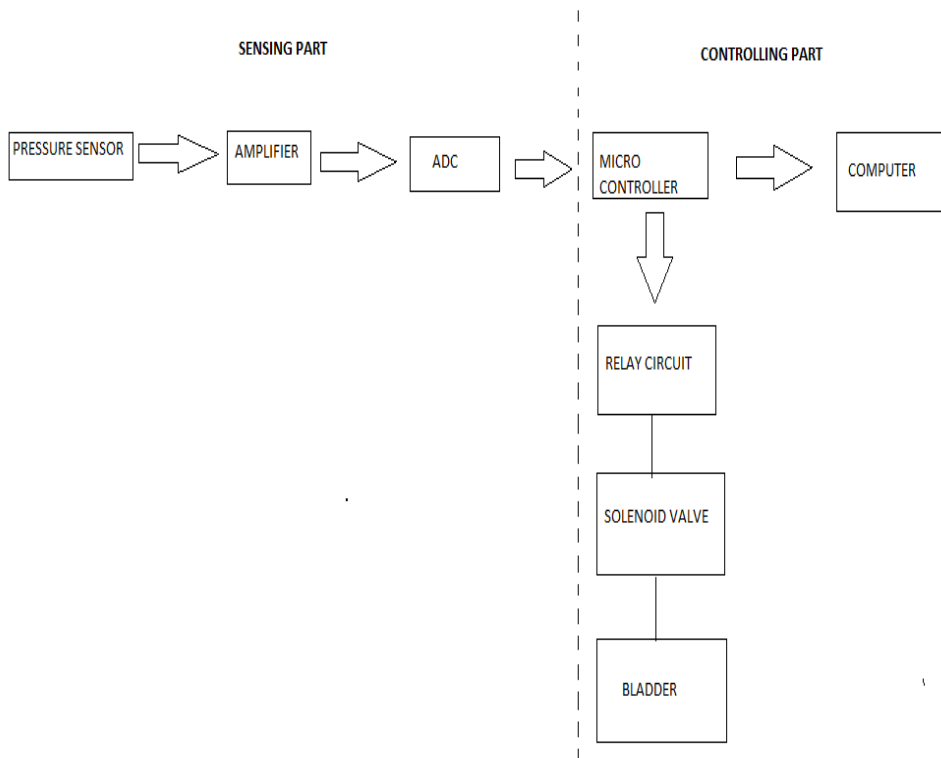

4. Methodology

1. Sensing Part

a) Air bladder and pressure sensor:

An air bladder is used to apply pressure to the body. To inflate the bladder the pump was activated and opened to allow air

flow in to the bladder. The bladder was deflated by opening valve ,allowing air to escape through a small hole placed in line between the pump and valve, as shown in the diagram. The bladder is inflated to about 15.5kPa(measured by mechanical manometer)and deflated to about 2.5kPa,such that the pressure was set to 1.2kPa.The pressure sensor module used is resistive type sensor are used to find the pressure inside air bladder.

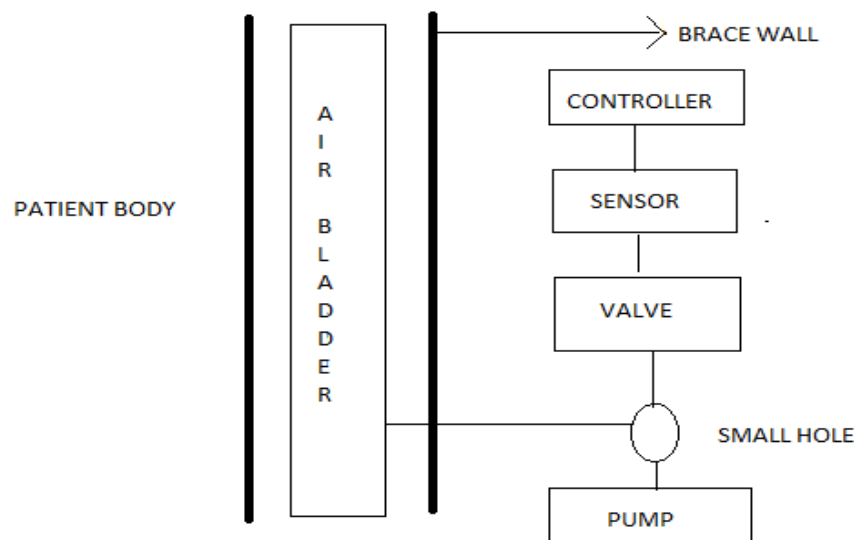

b) ADC0809:

signal from the sensor module and clock signal gets converted from the analog to digital signal. The input from the sensor are multiplexed by 8-bit multiplexer, an 8-bit A/D converter uses successive approximation by the conversion technique. This 0809 does not have inbuilt clock pulse generator, due to this condition ADC uses additional clock pulses from the IC7414.

c) Crystal oscillator:

Crystal oscillator generates the electrical signal with a very precise frequency given to the microcontroller. It is used to provide a stable clock signal for digital integrated circuits.

2. Controlling Part

a) Relay unit:

The relay unit collects the signal from the micro controller based on the frequency of the signal is high or low relay unit control the solenoid valves. It opened and closed by electromechanically and electrically, and it uses the smaller current to transfer the signal to other unit. The reed relays are used because this relay is possible to pass the signal to the solenoid part, It works very quickly because of small distance.

b) Solenoid valve:

It is coil of wire that collects the signal from the relay unit and it will open according electromagnetic principle, to inflate or deflate the air present in the bladder.

c) IC MAX 232:

IC MAX 232 is used to send the logged data of the average pressure inside air bladder for every 5 minutes. And send the data to computer station for analyzing and plotting. Computer interface software is used to program by visual basic programming, and contains the average pressure levels present in air bladders. Wear time is also noted.

5. Discussion

Although bracing is commonly non surgical prescribed treatment because of prescribed wear-time and the pressure at which the brace is worn are highly variable, if the patient is wearing the brace infrequently to the prescribed level ,the brace is not affecting the scoliosis. This system can be improved by the pressure applied by the brace while it is worn, resulting in better treatment outcomes. The system includes the pressure regulating units for installation at the brace. Monitoring the pressure sensor instead of force sensor is advantageous in a convectional braces the patient to reduce the force on the spine. This creates the active for the correction of mechanism.

6. Conclusion

A system was developed which regulates the pressure to specified level to correct the posture of spine. The system is valid 7days continuous test and fully charged battery could run or 30 days without the requiring a charge. The full benefit of this system is not only its ability to maintain a desired pressure , but also effect it has a patient's interaction with their braces.

References

- [1] E. Lou, V. J. Raso, D. Hill, J. Mahood, and M. Moreau, "Correlation between quantity and quality of orthosis wear and treatment outcomes in adolescent idiopathic scoliosis," *Prosthetics Orthotics Int.*, vol. 28,no. 1, pp. 49–54, 2004.
- [2] D. Katz, A. Herring, R. Browne, D. Kelly, and J. Birch, "Brace wear control of curve progression in adolescent idiopathic scoliosis," *J. BoneJoint Surg.*, vol. 92-A, no. 6, pp. 1343–1352, 2010.
- [3] M. Takemitsu, J. Bowen, T. Rahman, J. Glutting, and C. Scott, "Com-pliance monitoring of brace treatment for patients with idiopathic sco-liosis," *Spine*, vol. 29, no. 18, pp. 2070–2074, 2004.
- [4] R. Havey et al., "A reliable and accurate method for measuring orthosis wearing time," *Spine*, vol. 27, no. 2, pp. 211–214, 2002.
- [5] J. Mac-Thiong, Y. Petit, C. Aubin, S. Delorme, J. Dansereau, and H.Labelle, "Biomechanical evaluation of the Boston brace system for the treatment of adolescent idiopathic scoliosis: Relationship between strap tension and brace interface forces," *Spine*, vol. 29, no. 1, pp.26–32, 2004.
- [6] Andersen MO, Thomsen K et al (2007) Adolescent idiopathic scoliosis in twins: a population-based survey. *Spine (Phila Pa 1976)* 32(8):927–9
- [7] James, Lloyd Roberts and Pilcher, "Diagnosis of scoliosis based on age factor and sex ", 1959.
- [8] G. J. Donatell, D. W. Meister, J. R. O'Brien, J. S. Thurlow, J.G. Webster, F. J. Salvi, "A simple device to monitor flexion and lateral bending of the lumbar spine" *IEEE Trans. Neural Syst.Rehabil. Eng.*, vol.13, pp. 18-23, 2005.
- [9] Patias, P., 2002, Medical Imaging challenges Biostereometrics:A new era of Medical Photogrammetry, *ISPRS Journal Of Photogrammetry and Remote Sensing*, Volume 56, Issues 5-6, August, pp. 295-310.