

Harmonic reduction in a renewable energy islanded microgrid with fuzzy PID controller

N.S.Srivatchan ¹*, Dr.P.Rangarajan ²

¹ Research Scholar, Sathyabama Institute of Science and Technology, Chennai, India.

² Professor, R.M.D.Engineering College, India.

*Corresponding author E-mail: nss.eee@rmd.ac.in, prr.eee@rmd.ac.in

Abstract

Power sharing in an Islanded microgrid is not straight forward due to load variations as well as variable nature of Renewable Energy sources. This unequal power sharing leads to circulating currents, load imbalance and increased harmonic content. Traditional droop controller provides simple control for real power sharing without communication link, but they suffer from inaccurate reactive power sharing. To overcome the inherent drawback of traditional droop controller, this paper proposes cascaded H-bridge (CHB) multilevel inverter. CHB multilevel inverter provide increased output voltage, there by improves power quality. The Fuzzy Logic Controller provides simple and accurate control to CHB multilevel inverter. The proposed system is simulated in MATLAB Simulink Environment. This scheme provides closed loop control of DG units, in turn improves reactive power sharing between DG units, and thereby effectively reduces total harmonic distortion during islanding. The main focus of the paper is in power sharing issue on harmonic currents. The simulation results are verified with experimental microgrid hardware.

Keywords: Islanded Microgrid; Distributed Generator (DG); Reactive Power Sharing; Cascaded H- Bridge (CHB) Multi Level Inverter (MLI); Fuzzy Logic Controller (FLC); Total Harmonic Distortion (THD); Renewable Energy.

1. Introduction

Growing demand for flexible, reliable, high quality and green power can be realized through microgrids [1]-[2]. Microgrids are low voltage distributed Generation, consists of Renewable Energy Sources (Wind Turbine Generator and Photo Voltaic Generator, etc.) along with connected load and battery energy storage system. They have the advantages of less pollution, less transmission losses and higher efficiency. DG units are interfaced to distribution system through power electronic converters, which forms the microgrid. The microgrid operates in two modes viz., Grid Connected Mode and Islanded Mode [3]-[7]. In Islanded mode of operation, DGs can share the load demand using conventional droop controller without any need for communication [8]-[10]. The conventional droop controller can provide balanced and accurate real power sharing between DGs [8]-[14]. Due to poor impedance matching between DGs, as well as slower dynamic response of DG's, they tend to share reactive power inaccurately. Inaccurate reactive power sharing leads to circulating current and hence increased harmonic distortion and stability problems. As per IEEE standards 519 [15], the voltage total harmonic distortion should be within 5% in a distribution system.

To overcome the shortcomings of conventional droop controller, it is proposed to use Fuzzy Logic Controller (FLC) with CHB multilevel Inverter to reduce harmonic content of the system so that the Total Harmonic Distortion (THD) complies with the existing standards [16]. The CHB multilevel inverter provides the distribution system with better transient response, voltage support, power factor correction, flicker mitigation, voltage compensation and improved power quality [17]-[19]. Common topologies for multilevel inverters are diode clamped (neutral clamped), capacitor clamped (flying

capacitors) and Cascaded H Bridge (CHB). CHB are simple, does not require any clamping diode or flying capacitor. They require multiple dc sources which can be connected different DGs. CHB performance index is in terms of THD which is determined by the Pulse width modulation (PWM) strategy. The different PWM strategies that can be implemented are space PWM, Sinusoidal PWM and selective harmonic elimination and multicarrier PWM [20].

The main objective of CHB – multilevel inverter is to control real and reactive injection by adjusting the output voltage magnitude and phase angle [21]-[22]. Using this control method DGs can be used for unbalance voltage compensation. Different control strategy has been adopted for power quality problems through different control approaches. The effective control of energy management of microgrid will play a significant role for converting stable and cost effective microgrids into future smart grids. This paper is organized in VII Sections. Section II explains the configuration of the microgrid system. Section III provides the proposed CHB – Seven Level Inverter configurations. Section IV discusses the Fuzzy Logic control scheme for CHB – Seven Level inverter. Section VI gives discussion on simulation and experimental test results. Section VII provides the Conclusion.

2. Configuration of the microgrid system

The microgrid consists of Distributed Renewable generation Sources (DRES) viz Wind Electric Generator, Photovoltaic system, Battery Energy Storage System along with power electronic converter and local controller. The Microgrid is connected to the main grid through the Bidirectional Static Transfer Switch (BSTS) at the Point of Common Coupling (PCC). The connection status of the

microgrid to the main grid is sensed by the Microgrid Island Controller (MIC). In Grid connected mode, the main grid provides complete control and operates microgrid in PQ mode. In Islanded mode, Microgrid is disconnected from the grid, since there is no dominant source of energy, Island Controller (MIC) takes over the control, operates the microgrid in Master-Slave mode using V/f control.

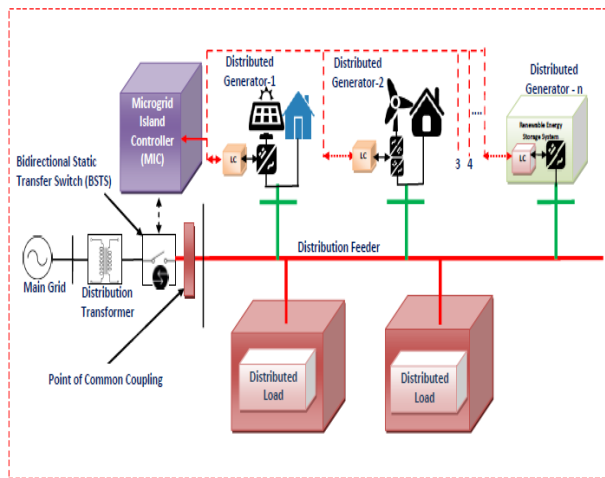

Fig. 1: Configuration of the Microgrid System.

2.1. Conventional droop control

Figure.2 shows the equivalent circuit model of DG unit and it is given by.

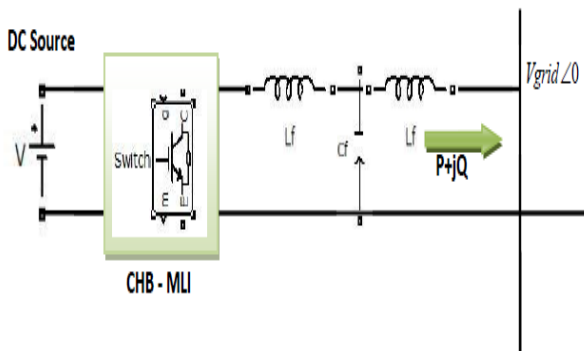

Fig. 2: Circuit Model of DG Unit.

The expression for conventional droop controller is given by following equations.

$$f = f_0 - K_P (P - P_0) \quad (1)$$

$$V = V_0 - K_Q (Q - Q_0) \quad (2)$$

Where, P & Q - load power demand.

P₀, Q₀ - base load power.

f, V - Reference voltage and frequency.

K_P, K_Q - frequency and voltage droop coefficients.

However due to dynamic nature of the DG system and Feeders, the power sharing is not accurate.

3. Proposed control strategy

To overcome the drawback of conventional droop control power sharing errors need to be accurately calculated to reduce the harmonic content at the output.

3.1. Power sharing error calculation

To compensate for the feeder impedance and to provide accurate real and reactive power sharing, the system is modeled into positive

sequence, negative sequence and harmonic sequence. Positive sequence consists of impedance of the feeder (ZPS_feeder) and Distributed Generator virtual Impedance (ZPS_VGen), it is given by Impedance at Positive Sequence

$$ZPS = (ZPS_feeder + ZPS_VGen) \quad (3)$$

Similarly, Impedance at Negative Sequence,

$$ZNS = (ZNS_feeder + ZNS_VGen) \quad (4)$$

Impedance at Harmonic Sequence,

$$ZHS = (ZHS_Feeder + ZHS_VGen) \quad (5)$$

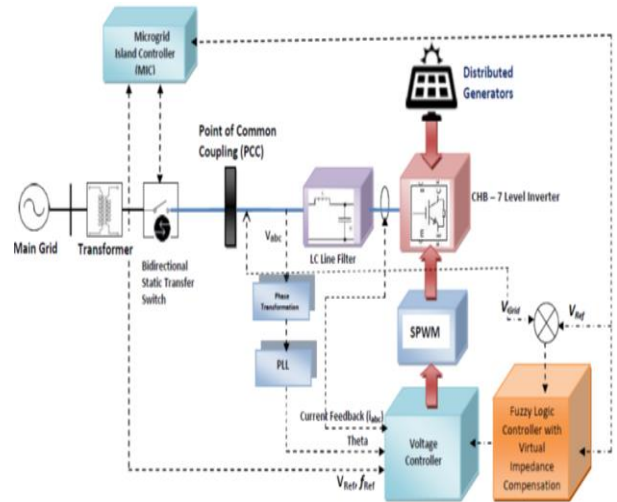

Fig. 3: Configuration of Proposed Control Strategy.

The sequence impedance provides accurate power sharing between DG's in comparison with conventional droop control. However calculating the feeder impedance is complex and this will increase burden for the local controller. To overcome the above drawback, transient droop control technique is used and it can directly get the dynamic impedance and does not require the value of feeder impedance to compensate for power sharing errors.

The positive, negative and harmonic sequence current components are detected using sequence decomposition method. With the help of sequence currents, Real Power (P), Reactive Power (Q), Harmonic Power (Q_{Har}) and Imbalance Power (Q_{ns}) are calculated. Harmonic studies indicates that the effects of lower order harmonics are dominant as compared to higher order harmonics,. Hence Harmonic Power is calculated only for dominant lower Order harmonics and higher order harmonics are not considered.

Real Power is given by

$$P = \frac{3}{2(\tau S + 1)} \cdot (V_{DG-\alpha} \cdot I_{\alpha-ps} + V_{DG-\beta} \cdot I_{\beta-ps}) \quad (6)$$

Similarly, Reactive Power,

$$Q = \frac{3}{2(\tau S + 1)} \cdot (V_{DG-\beta} \cdot I_{\alpha-ps} - V_{DG-\alpha} \cdot I_{\beta-ps}) \quad (7)$$

Harmonic Power,

$$Q_{Har} = \frac{3}{2} V_{DG-peak} \cdot \sqrt{(I_{\alpha-5})^2 + (I_{\beta-5})^2 + (I_{\alpha-7})^2 + (I_{\beta-7})^2}$$

Imbalance Power,

$$Q_{ns} = \frac{3}{2} V_{DG-peak} \cdot \sqrt{(I_{\alpha-ns})^2 + (I_{\beta-ns})^2} \quad (9)$$

These transient power variations (errors or deviations) are added to the conventional droop controller, to provide improved power sharing between DG's at steady state. Thus proposed scheme provides improved power sharing under reactive, imbalance and harmonic loads, and reduces the Total Harmonic Distortion (THD) in an Isolated microgrid.

3.2. CHB - seven level inverter

Harmonics are predominant in an islanded microgrid; they are not eliminated by traditional two or three level inverter. In order to improve the total harmonic distortion in an islanded microgrid, it is proposed to implement three phase Cascaded H – Bridge Seven Level Inverter with fuzzy logic controller.

The number of phase voltage level at the converter terminals is $2N+1$, Where N is the number of dc link voltages. As the number of level increases it improves the voltage and power quality, however it also increases the complexity and associated cost. Since seven level inverter can operate in higher switching frequency as compared to five level inverter, it requires small value of filtering requirements.

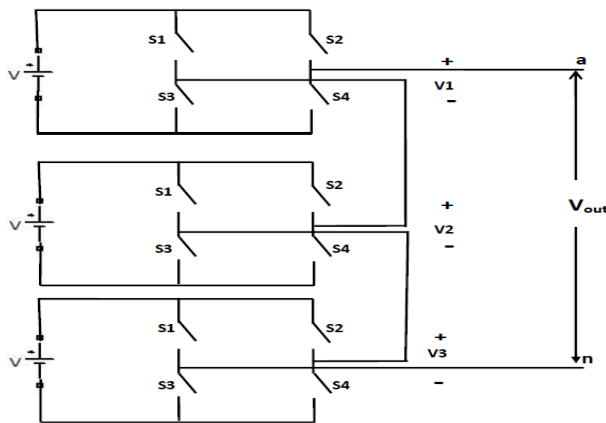

Fig. 4: Seven Level Inverter Switch Model.

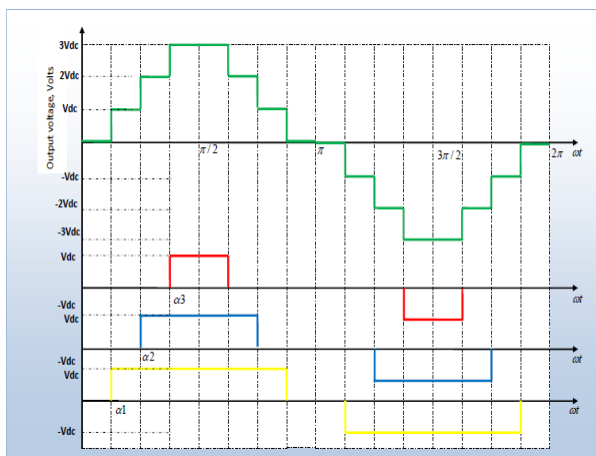

Fig. 5: Seven Level Inverter Output.

Each cell has separate voltage source connected to dc link capacitor. The number of dc link capacitors is proportional to number of phase voltage levels. Each HB cell may have positive, negative or zero voltage. The output voltage is sum of all Cell voltages and it is symmetric with respect to neutral point, hence number of voltage level is odd. 12 IGBTs are used as switches for CHB multilevel inverter as they have high switching frequency and low blocking voltage. The output voltage of Cascaded H Bridge seven level inverter is in the shape of step or staircase without filter. With proper LC filter design, sine wave is obtained.

3.3. CHB seven level inverter with fuzzy logic controller

The CHB Seven level inverter is switched using fuzzy logic controller. The fuzzy logic controller provides required voltage compensation by incorporating virtual impedance droop control. Due to reactive power compensation with virtual impedance, the total harmonic distortion at the output is reduced. The inputs to the fuzzy logic controller are

$\delta v - V_{grid} - V_{Ref}$ - Difference Grid/Inverter output voltage and the reference voltage provided by the Microgrid Island controller.

V_{Ref} – Reference voltage set by the Microgrid Island Controller. The output of the Fuzzy Logic controller is applied to the CHB – 7 level inverter gate drivers. Modulation index is selected by the FLC – PID Controller, thereby provides voltage stability and Harmonic reduction during Islanded operation.

3.4. Fuzzy logic controller for CHB seven level inverter

Problem Formulation:

In an Islanded microgrid there is a fluctuation of reactive power and it leads to voltage deviation. The fluctuation can be eliminated by matching the generation with respect to load demand. Therefore the main objective in an islanded microgrid is to minimize voltage deviation (δv) and it is given by the function

$$\text{Minimize } E = \int \delta v \, dt \tag{10}$$

Conventional PI Controller is simple and it can eliminate the steady error. The drawback of conventional controller is that they cannot predict future errors, slow to respond, unstable, overshoots as well as leads to oscillations. The drawback of PI controller can be overcome by using PID controller.

PID Controller can provide Zero Steady error, fast response, and higher stability without any oscillations. Performance of PID controller can be enhanced by tuning the parameters through self tuning or self organizing control. One of the cost effective adaptive control is Fuzzy Logic controller. The Fuzzy PID controller improves the system response by automatic tuning of PI controller.

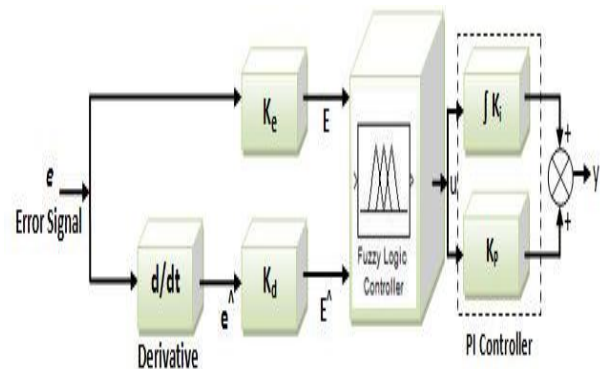

Fig. 6: Configuration of Fuzzy PID Controller.

The Fuzzy Logic PID controller consists of Fuzzy Logic Controller and a conventional PI Controller. FLC has two inputs namely error (e) and derivative of error ($e^$), based on the voltage deviation (δv) and it produces a single output (u).

Output of the Fuzzy Logic Controller is given by

$$u = A + PE + DE^ \tag{11}$$

Where $E = K_e * e$ and $E^ = K_d * e^$

The output (u) of FLC is given to the conventional PI Controller. The output (y) of the Fuzzy PID Controller is given by

$$y = KP * u + Ki * \int u \, dt \tag{12}$$

Substituting the equation (11) in (12), we get

$$y = K_P A + K_i A t + K_{PP} K_e e + K_i P K_e \int e dt + K_P D K_d e^{\wedge} + K_i D K_d e$$

Equation (6) can be rewritten as

$$y = PG + IG + DG + EG$$

Where,

PG - Proportional Gain ($K_P K_e e P + K_i K_d e D$)

IG - Integral Gain ($K_i K_e P$)

DG - Derivative Gain ($K_P K_d D$)

The control signal (y) commands current controller to operate in constant frequency mode to stabilize islanded microgrid. The key objective in fuzzy PID controller design is to determine gain values for Proportional (K_P), Integral (K_i), Derivate (K_d) and Error (K_e). The membership function (MF) and Control Rules (CR) for two input (e & e[^]) and one output (u) of FLC is formulated using two shapes.i.e triangular and trapezoidal. Triangular memberships are given by three parameters, Left base (LB), Centre (C) and Right base (RB). Trapezoidal memberships are defined by four parameters, Left base (LB), Centre 1 (C1), Centre (C2) and Right base (RB). Each Membership Function has two trapezoidal memberships and five triangular memberships and it is given by the following shape.

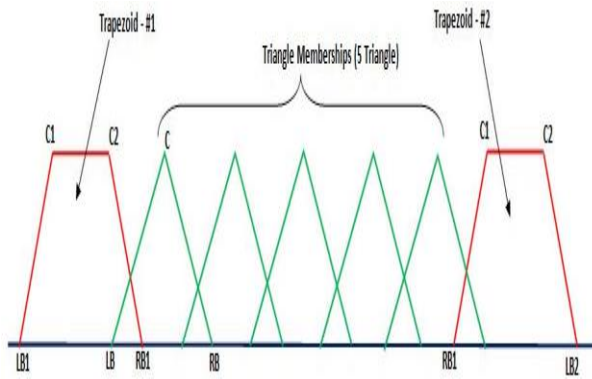

Fig. 7: Shape of Fuzzy Membership Function.

Accordingly each membership function (MF) consists of 23 (4+3+3+3+3+3+4) tuning parameters. Since FLC has two inputs and one output, therefore totally there are 69 parameters (3 X 23 = 69). This idea is applied to the Fuzzy Logic toolbox with n=7 (Total number of relationships) with all possible input pairs (7) gives 49 parameters. Therefore the total parameters for two input one output FL PID controller is 122.

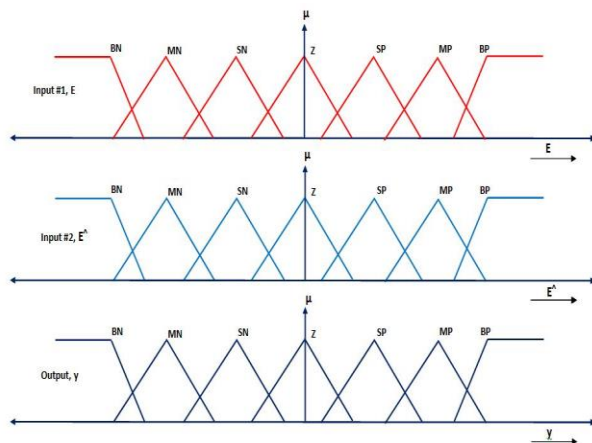

Fig. 8: Membership Functions.

Where, BN – Big Negative; MN – Medium Negative ; SN-Small Negative; Z- Zero; SP – Small Positive; MP – Medium Positive; BP – Big Positive.

| | | Input #2, E [^] | | | | | | |
|-------------|----|--------------------------|----|----|----|----|----|----|
| | | BN | MN | SN | Z | SP | PM | PB |
| Input #1, E | BN | BN | BN | BN | MN | MN | SN | Z |
| | MN | BN | BN | MN | MN | SN | Z | SP |
| | SN | BN | MN | MN | SN | Z | SP | MP |
| | Z | MN | MN | SN | Z | SP | MP | MP |
| | SP | MN | SN | Z | SP | MP | MP | BP |
| | MP | SN | Z | SP | MP | MP | BP | BP |
| | BP | Z | SP | MP | MP | BP | BP | BP |

Fig. 1: Fuzzy Rule Table.

The important aspect FLPID controller design is in determination of control rules. They are usually obtained by trial and error as well as through designers experience on physical systems.

3.5. Parameters of the microgrid

Table.2: Simulation and Hardware Parameters

| Symbol | Description | Parameter |
|----------------------------------|-------------------------------|------------|
| Microgrid Simulation Parameters | | |
| VGrid | Grid Voltage | 280 V |
| fGrid | Grid Frequency | 50Hz |
| fswitching | Switching Frequency | 8 kHz |
| PPV | Solar Panel Rating | 2 kWatts |
| PWTG | Wind Turbine Generator Rating | 2 kWatts |
| SInv | Inverter Rating | 10KVA |
| Bah | Battery Rating | 100 Ah |
| PLoad | Load Rating | 2KW+j1kVAR |
| Experimental Hardware Parameters | | |
| VGrid | Grid Voltage | 230 V |
| fGrid | Grid Frequency | 50Hz |
| fswitching | Switching Frequency | 8 kHz |
| PPV | Solar Panel Rating | 500 watts |
| PWTG | Wind Turbine Generator Rating | 500 watts |
| SInv | Inverter Rating | 3 kVA |
| Bah | Battery Rating | 100 Ah |
| PLoad | Load Rating | 1 kWatts |

4. Simulation

The model is designed based on the above parameter in MATLAB Simulink environment. To show the effectiveness of the CHB-multilevel inverter, comparison is made between five and seven level inverter. The microgrid is islanded, through the circuit breaker from 50 mSec to 100 mSec during which the total harmonic distortion (THD) is calculated and compared.

4.1. Simulation outputs

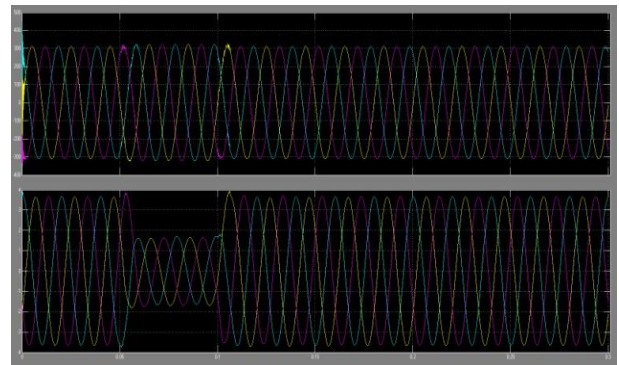

Fig. 9: Input Voltage and Current for Seven Level Inverter.

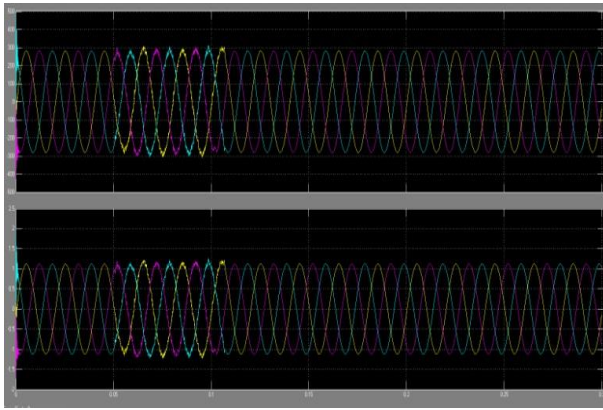

Fig. 10: Output Voltage and Current for Seven Level Inverter.

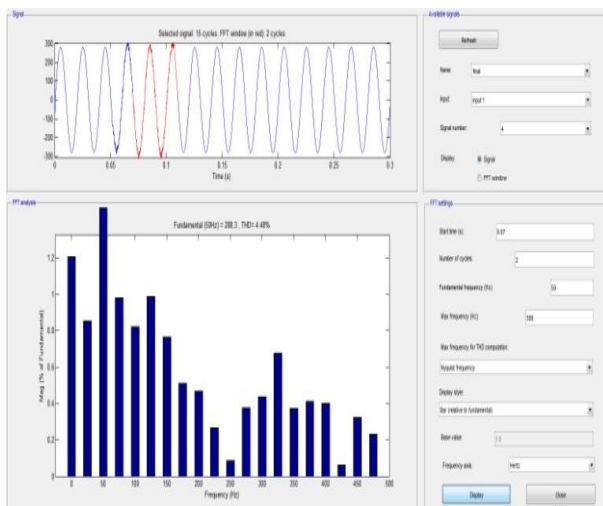

Fig. 11: Output Voltage and THD for Seven Level Inverter.

Output voltage THD of CHB – Seven Level Inverter is 4.95% for CHB – Five Level Inverter. It clearly highlighted the effectiveness of CHB – Seven Level Inverter with fuzzy logic controller.

4.2. Experimental results

Experimental microgrid hardware consists of wind turbine generator (WTG), photovoltaic system (PV), battery energy storage system (BESS) and three phase seven level bridge inverter with fuzzy logic controller (FLC).

The experimental hardware is designed and tested for experimental hardware based on the above parameter and it produced the same total harmonic distortion as 4.95 % (THD).



Fig. 12: Microgrid Hardware Setup at RMD Engineering College.

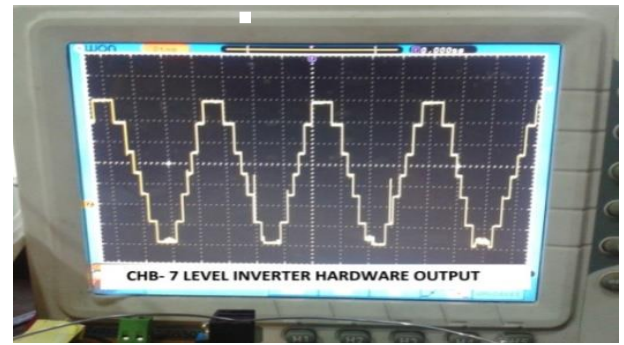

Fig. 13: CHB – Seven Level Inverter Output without Filter.

5. Conclusions

In this paper, harmonic reduction through power electronic interface between DGs and AC microgrid is proposed. The proposed scheme reduces the Total Harmonic Distortion in an islanded microgrid through Multi level inverter and fuzzy logic PID controller. The proposed control is implemented by designing the fuzzy logic controller by tuning the multi level inverter. This in turn improves the reactive power sharing between the DGs. Thus proposed system provides improved reactive power sharing, and hence reduces THD to 4.95%. The simulation and experimental results are provided to verify the effectiveness of the proposed control strategy.

Acknowledgement

This is a text of acknowledgements. Do not forget people who have assisted you on your work. Do not exaggerate with thanks. If your work has been paid by a Grant, mention the Grant name and number here.

References

- [1] Thomas Ackermann, Göran Andersson and Lennart Söder, "Distributed generation: a definition", Vol.57, Issue 3, 195-204, 2001.
- [2] Lasseter. R, "Microgrid:A Conceptual Solution," PESC'04 Aachen, Germany 20-25 June 2004.
- [3] Meegahapola, L.G, A.P.Agalgaonkar,S.Perera and P.Ciufo, "Microgrids of Commercial Buildings: Strategies to Manage Mode Transfer from Grid Connected to Islanded Mode" IEEE Transactions on Sustainable Energy, Vol.5, No.4, October 2014.
- [4] J. A. Peças Lopes, C. L. Moreira, and A. G. Madureira, "Defining Control Strategies for MicroGrids Islanded Operation", IEEE Transactions On Power Systems, Vol. 21, No. 2, May 2006.
- [5] Josep M. Guerrero, Juan C. Vásquez, and Remus Teodorescu, "Hierarchical Control of Droop-Controlled DC and AC Microgrids – A General Approach Towards Standardization" IEEE Transactions on Industrial Electronics, Vol.58, Issue.1, 158-172, August 2010.
- [6] Ali bidram, Ali Davoudi and Frank.L.Lewis, "A Multiobjective Distributed Control Framework for Islanded AC Microgrids", IEEE Transactions on Industrial Informatics, Vol.10,No.3,August 2014.
- [7] Navid Eghtedarpour and Ebrahim Farjah, "Power Control and Management in a Hybrid AC/DC Microgrid,"IEEE Transactions on Smart Grid, Vol.3,no.3,1494-1505, May'2014.
- [8] N.S.Srivatchan, et al., "Control Challenges and Techniques in Islanded Micro Grid Operation" International Journal of Applied Engineering Research, vol. 10 No.12, pp. 30883-30900, 2015.
- [9] Farag, H.E, Abdelaziz, M.M.A.and El-Saadany, E.F. "Voltage and Reactive Power Impacts on Successful Operation of Islanded Microgrids", IEEE Transactions on Power Systems, Vol.28, Issue.2, 1716-1727, May'2013.
- [10] Micallef,A, Apap,M, Spiteri-Staines,C, Guerrero, J.M and Vasquez, J.C. "Reactive Power Sharing and Voltage Harmonic Distortion Compensation of Droop Controlled Single Phase Islanded Microgrids", IEEE Transactions on Smart Grid, Vol.5, Issue.3, 1149-1158, April'2014.
- [11] N.S.Srivatchan, et al, "Control Scheme for power quality improvement in Islanded microgrid operation", Procedia Technology, Vol.21, pp.212-215, 2015.

- [13] Omar Abdel-Rahim, Mohamed Orabi and Mahrous E. Ahmed, "High Gain Single-Stage Inverter for Photovoltaic AC Modules" Applied Power Electronics Conference and Exposition (APEC), Page No.191-1967, 6-11 March'2011.
- [14] Mahrous El-Sayed Ahmed, Mohamed Orabi, Omar Mohamed AbdelRahim, "Two-stage micro-grid inverter with high-voltage gain for photovoltaic applications", IET Power Electronics, pp1-10, 2013.
- [15] Zhihao Zhang, Xinhong Huang, Jin Jiang and Bin Wu "A load-sharing control scheme for a microgrid with a fixed frequency inverter" Electric Power Systems Research, Vol.80, Issue.3, 311-317, March 2010.
- [16] IEEE Recommended practices and Requirements for Harmonic Control in Electrical Power System. IEEE Standard 519, 1992.
- [17] Carlo Cecati, Fabrizio Ciancetta, Pierluigi Siano, "A Multilevel Inverter for Photovoltaic Systems with Fuzzy Logic Control", IEEE Trans. Ind. Electron., vol. 57, no. 12, pp. 4115 -4125, Dec. 2010.
- [18] Y.A.R.I.Mohamed and E.F.El-saddany, "A Control scheme of grid connected PWM source inverters for fast load voltage regulation and effective mitigation of unbalanced voltage disturbances", IEEE Trans.Ind.Electron., vol.55, no.5, pp. 2072-2084, May 2008.
- [19] C.J.Gajanayake, D.M.Vilathgamuwa, P.C. Loh, R.Teodorescu, and F.Blaabjerg, "Z-source-inverter-based flexible distributed generation system solution for grid power quality improvement," IEEE Trans.Energ.convers., vol.24, no.3, pp. 695-704, sep.2009.
- [20] J.He, Y.W.Li, and M.S.Munir, "A flexible harmonic control approach through voltage controlled DG grid interfacing converters," IEEE.Trans.Ind.Electron, vol.59, no.1, pp. 444- 455, Jan.2012.
- [21] Jose Rodriguez, Jin-Sheng Lai and Fang Zheng, "Multi level Inverters: A survey of topologies, Control applications," IEEE Trans.Ind.Electronics, Vol.49, No. 4, pp. 724-738, 2002.
- [22] Majumder.R, Ghosh.A,Ledwich.G and Zare.F. "Operation and control of hybrid microgrid with angle droop controller" TENCON 2010 - 2010 IEEE Region 10 Conference, 509-515, Nov.2010.
- [23] Majumder.R, Ghosh.A,Ledwich.G and Zare.F " Improvement of Stability and Load Sharing in an Autonomous Microgrid Using Supplementary Droop Control Loop" IEEE Power and Energy Society General Meeting, 2010.