

Optimization of energy from photovoltaic cell using three port converter for home appliances

Jagadeesh Kumar M ^{1*}, Jayanthi G ², Priyadharshni ², Subhikshaa S ², Sivaranjani K ²

¹ Professor, Department of EEE, Sri Sai Ram Institute of Technology

² Department of EEE, Sri Sai Ram Institute of Technology

*Corresponding author E-mail: jagadeeshkumar.eee@sairamit.edu.in

Abstract

The main objective of this paper is to propose the significant usage of photovoltaic modules in household applications. This paper describes a compact but fully functional design by integrating basic converters to form a simplified single inductor converter structure while keeping minimum number of switches. The resultant converter is fully reconfigurable that all possible power flow combinations among the sources and load are achieved through different switching patterns. Single inductor converter module is used to simplify the structure while reducing the number of switches. This is fully configurable enabling all possible power flow combinations. The experimental behavior of this module from morning till evening is observed and the wave pattern of the subjective proposed results are recorded and verified.

Keywords: MPPT Algorithm; Non-Isolated Three Port Converter; Photovoltaic Cell; Zero Voltage Switching; PI Controller.

1. Introduction

At first multiport converters are classified as isolated and non-isolated converters [1]. The comparison between isolated, partly isolated and non-isolated is given in [2]. Recently Non-isolated three port converters are widely used in many renewable energy applications which are used to integrate energy storage and load owing to the fact of requirement of low voltage regulation ratio [3]. Non-isolated converters are used for multiple input and multiple output configurations and is cheaper and very compact in size compared to isolated converters because of its reduced size. Three port converters have the benefit of single stage power conversion between two ports. The TPCs designed for power consuming loads are reviewed in [1]. The control strategies are derived from [4]- [5]. [13] proposes the idea of three-port converter for energy storage in four modes of operation according to the availability of solar energy. MPPT algorithm is proposed in this paper. MPPT algorithm is used for maximum power generation in PV panel and to utilize availability solar radiation effectively. Hardware implementation of DC-DC converter for MPPT in PV applications is given in [6]. In addition to this Zero voltage and soft switching [7] for non-isolated bidirectional converter is preferred for battery to interface with AC grid with reduced number of switches and high voltage gain.

The following features have been preferred for NTPC to maintain a single stage power conversion and for interfacing with a bidirectional load.

- 1) With the use of single inductor, power density is improved while the cost and size are reduced.
- 2) It controls and integrates the current reversible load.
- 3) With the use of Zero Voltage Switching, soft switching is possible there by switching loss is reduced while efficiency increases.
- 4) It is reconfigured into following mode for possible combinations among three ports. The possible combinations are
 - a) DISO (Dual-input single-output)
 - b) SIDO (Single-input dual output)
 - c) SISO (Single-input single-output)

- a) DISO (Dual-input single-output)
- b) SIDO (Single-input dual output)
- c) SISO (Single-input single-output)

The conventional method [11] of usage of regenerative braking in the load such as DC motor or a DC bus is employed to the AC grid control. But these methods include number of switches which increase the complexity of the circuit. Hence, a more effective and a fully functional design is proposed introducing a new concept of non-isolated three-port converter with zero voltage switching methods for current chopping. Also proposed paper describes about the usage of solar and AC grid at the same time. The Non-Isolated Tri port converter topology is used hence Bi-directional flow is possible. Zero voltage and soft switching is used to increase efficiency. Here six modes of conversion are possible and according to voltage difference the converter automatically select the mode and Single inverter is used to boost the voltage. Hence it has advantages such as usage of Hybrid energy, the stable system in all the operating conditions, low inductive loss, etc.

2. Circuit configuration

The proposed converter is shown in Fig1. This converter incorporates a three-port converter (TPC). PV panel, battery and inverter-rectifier converter forms the three ends of the TPC. The PV panel becomes the input to the converter which is a unidirectional. The other two are bi-directional in which reversible power flow is possible. The three ports have the voltage sources as V_{pv} , V_b , and V_{op} respectively. The three-port converter is made to operate at a voltage setting of $V_{pv} < V_b < V_{op}$ for better optimization of photovoltaic energy. Hence an integrated buck-boost converter is designed. In order to achieve the efficient operation of the converter, zero voltage switching is applied using the capacitors C_4 , C_5 , C_6 across the switches. The inductor L is the storage element for the input which either steps up or down its voltage for the desired output. The power switches like MOSFET's are used for switching purpose through S_1 , S_2 , and S_3 . In order to operate the inductor to store the energy switch

S1 is employed. S₁, S₂, S₃ and S₄ switches used to realize the MPPT technique. Switch S₅, S₆, S₇ and S₈ are used for inversion and rectification process which are controlled separately and depends on State of Charge of battery and PV voltage. The switch S₂ is used for controlling the current to load and S₃ is used to discharge the energy from the battery. An additional switch S₄ is added for achieving the bidirectional power flow. Diode D₁, D₂ and D₃ is used to restrict the current from flowing back in that branch from load. The diodes D₂ and D₃ also act as the output rectifiers for the boost converter of inverter-rectifier and battery. The capacitors C₁, C₂, C₃ are used as filters for the PV cell, battery and inverter respectively.

3. Circuit operation

As the two bidirectional ports in NITPC provide power flow in different combinations, it enables the system to operate in 6 different modes. Mode 1 to 4 are considered as a grid connected mode as the DC bus is a current reversible load and the remaining two modes are considered as islanded mode. Any fault occurrence in the distribution system can lead the DC bus as off grid which is called as islanded mode. Zero voltage switching is added for the improvement of efficiency and power factor by eliminating the incomplete case of soft switching and non-zero losses. Fig 2 represents modes of operation using conventional method [11]. Conventional method [11] uses regenerative braking to charge the battery and its purpose is to ensure continuous power to the battery whereas proposed system is to ensure continuous power to the load by charging the battery and it acts as a bi-directional. Fig.1 represents the proposed converter topology which includes Zero Voltage Soft Switching in switches S₁, S₂, S₃ through capacitors C₄, C₅, C₆. Inversion – Rectification process is used for effective use.

Mode 1: PV to battery and Load

This mode is operated when the PV power is greater than the required power of the load. Hence it works as a SIDO boost converter. In this mode, the PV power equals the sum of the battery and the

DC bus. When S₁ turns on, L₁ stores the energy. S₂; D₂ and D₃ provide two current paths when S₁ is turned off. The amount of charging current is limited when the battery has full State of Charge.

Mode2: PV to Load

In this mode the PV supplies its energy to load only using PI controller in order to minimize the error over time. The converter operates as a SISO boost converter. S₁ and D₂ work in a complementary manner, and S₁ is used to implement the MPPT. To reduce switching loss, S₂ is turned on for the whole operation mode. D₅ will not conduct since the diode D₄ is reverse biased.

Mode 3: PV and battery to Load

This mode works when the PV power is insufficient to meet the load demand and also the DC bus is off grid. Hence both PV and the battery power are supplied to DC bus. This mode has DISO converter structure. There are two switching techniques which depend on the availability of the PV power. In this mode, S₁ is turned on to allow the MPPT function of PV and L₁ is charged. When S₁ turns off, L₁ gets discharged together with battery and PV.

Mode 4: Battery to Load

This mode operates when PV is unable to supply the power to the load. This mode is operated as a SISO boost converter. Hence the battery has to supply the sufficient power to the load by turning on the switch S₁ which stores the energy in L₁. When S₁ turns off, L₁ releases the energy to the load through D₂.

Mode 5: AC Source to Battery

When there is no PV power, this mode provides some energy for backup. Hence the charging of the battery is done by the DC bus. An extra switch S₄ and diode D₅ are added. By turning ON the switch S₄, DC bus delivers the power to the battery. Switch S₁ is turned ON to store energy in L₁ and S₁ is then turned off to deliver the power to the battery through the diode D₃.

Mode 6: PV to Battery

In this mode, the converter works as a SISO boost converter. When there is no load requirement, then the power is delivered to charge the battery. When S₁ turns on, L₁ is charged and when S₁ is turned off L₁ releases the energy to battery through D₃.

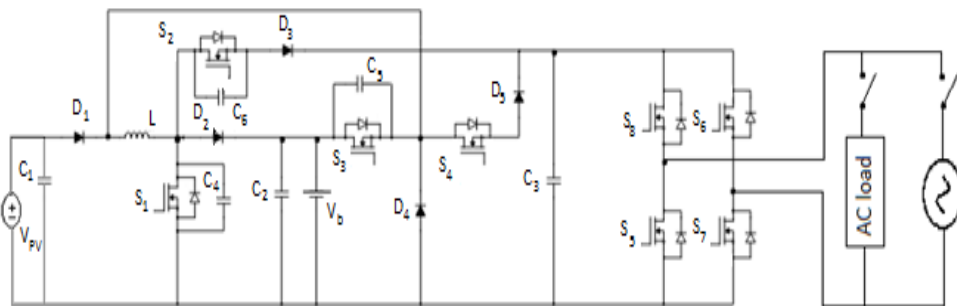

Fig. 1: Proposed Converter Topology.

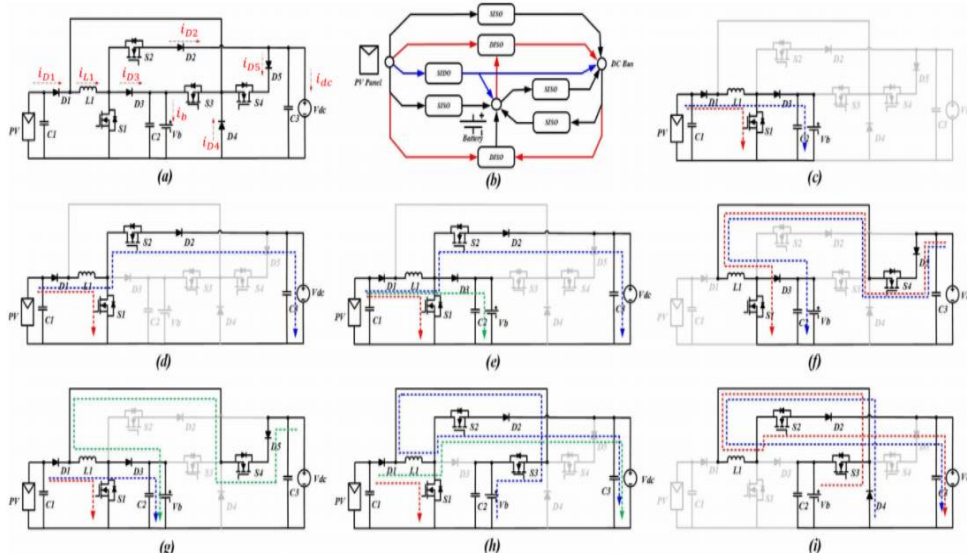

Fig. 2: Modes of Operation [11].

3.1. Inversion- rectification process

The AC load and AC grid are connected to the inverter-rectifier converter through the breaker. When there is no supply from the source and the state of charge is below a certain limit, the converter act as rectifier. AC grid gets connected to the rectifier and act as input. Switch S_4 and S_2 turns on and turns off accordingly charging the battery either when source voltage or state of charge of the battery reaches the specified limit.

The converter neither act as inverter nor rectifier when the battery is charged by the PV panel. The load gets connected to the converter and it act as inverter in all other four modes.

3.2. MPPT algorithm

The V-I characteristics of PV module is non-linear. Maximum power point of the curve changes depending upon temperature, irradiation level and load electric characteristics. It is tracked continuously using various MPPT techniques to obtain maximum output

power from the photovoltaic array. Various techniques are analyzed in [8]. In [9] the photovoltaic array is modeled using P&O MPPT algorithm due to its simple operation and high efficiency. Perturb and observe method perturb the control variable and compare with the instantaneous output power of PV.[14] The next perturbation direction is determined by the comparison result together with PV voltage condition. The limitations of applying fixed step size in performing MPPT is overcome by using variable step size which improves the speed and accurate location of MPP [10].

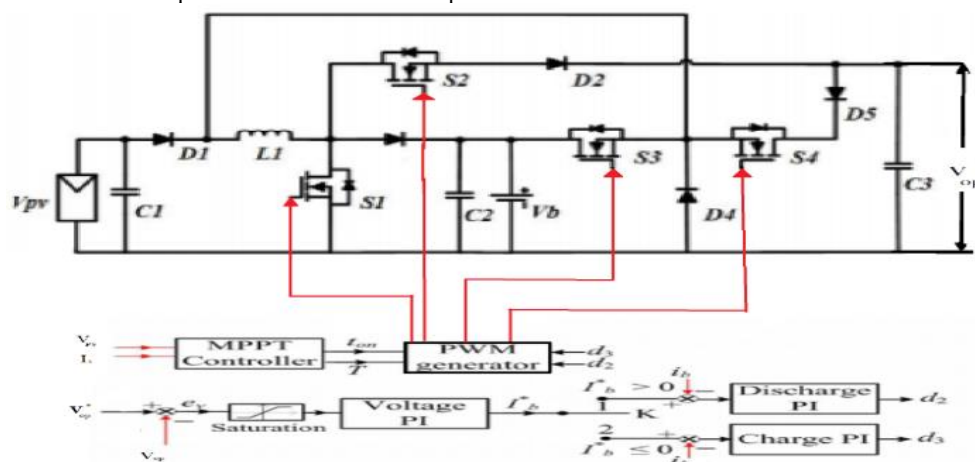

Fig. 3: Three Port Converter with Controller Modeled Using MPPT Algorithm.

The step size of P&O based MPPT algorithm is suitably varied in the P&O algorithm of [12]. When the system operates away from MPP, the perturbation step size is increased. If the system operating point fluctuates near the MPP, the perturbation step size is decreased which changes the reference voltage hence reducing the fluctuation by a great extent. In this paper a developed P&O algorithm is considered by adapting the step size of P&O based MPPT. Thus, the tracking speed problem and oscillation near MPP are efficiently limited.

3.3. PI Controller

MPPT algorithm is used in PV panel for maximum power generation by utilizing the maximum solar radiation. The pulses are given from PI controller using PWM technique. This is because controller attempts to minimize the error over time by adjustment of a control variable, such as the position of a control valve, a damper, or the power supplied to a heating element.

The final form of the PID algorithm is:

$$u(t) = MV(t) = K_p e(t) + \int K_i e(t) dt$$

Where

- K_p : Proportional gain, a tuning parameter
- K_i : Integral gain, a tuning parameter
- e : Error
- t : Time or instantaneous time (the present).

4. Design of simulation circuit

The pulses are given from PI controller using PWM technique. This is because controller attempts to minimize the error over time by

adjustment of a control variable, such as the position of a control valve, a damper, or the power supplied to a heating element. MPPT algorithm is used in PV panel for maximum power generation by utilizing the maximum amount of solar radiation.

According to the voltage generated by PV panel the simulation is designed in the following modes.

Mode 1: PV to Battery and Load

This mode enables the flow of voltage from photovoltaic panel to the battery and the load. If the voltage on the panel exceeds 20 V then the power flows from the panel to the battery for storage and will be supplied to the load.

Mode 2: PV to Load

This mode operates from the voltage range of 18-20 V. If the available voltage is in the specified range the power flows from the PV panel to the load alone

Mode 3: PV and Battery to Load

This mode of operation is enabled from a voltage range of 2 -17 V. The power flow is from the PV panel and the battery. The load is supplied from both the sources.

Mode 4: Battery to Load

If the PV panel voltage is less than 2 V. Then power is supplied to the load from the battery alone.

Mode 5: AC Source to Battery

If the PV panel voltage is less than 2V and the battery charge is less than 10 % of the nominal value, then the AC power supplies the battery.

Mode 6: PV to Battery

If the load is disconnected from the source, then the power flows only from the PV panel to the battery.

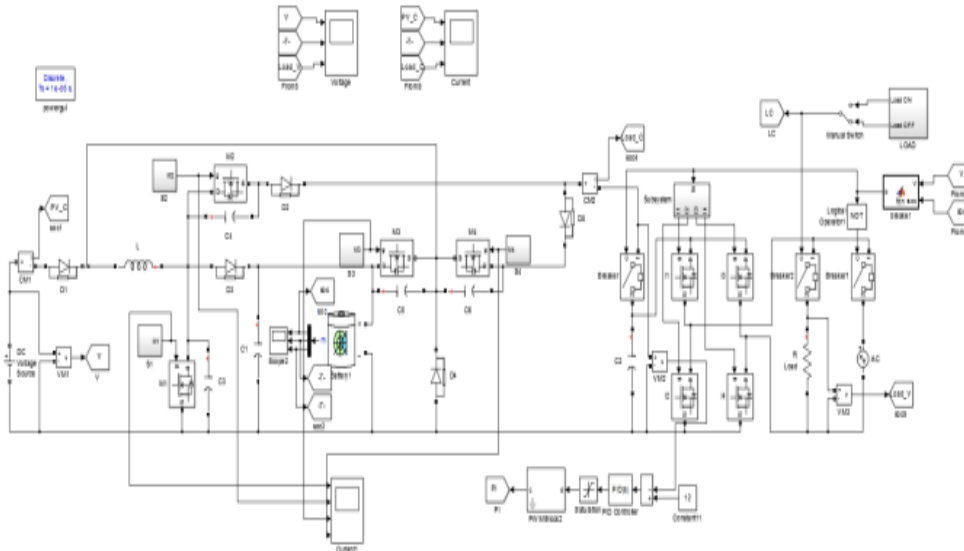

Fig. 4: Simulation Circuit Diagram.

4.1. Variations of power flow

The Solar power can't be available all time in a day. According to the availability of solar radiation in a day, there are three working scenarios. Fig. 8 describes the V-I curve for the same. The three scenarios are given as

- 1) During maximum solar radiation, the voltage is generated is maximum and the power is given to both battery and load.
- 2) During cloudy conditions, the solar radiation is not efficient. Voltage is given to load from both PV panel and battery
- 3) This scenario is of two cases. They are
 - During night time battery supplies power to load.
 - When the battery state of charge is less than 10% AC source supplies power to battery and battery supplies power to load.

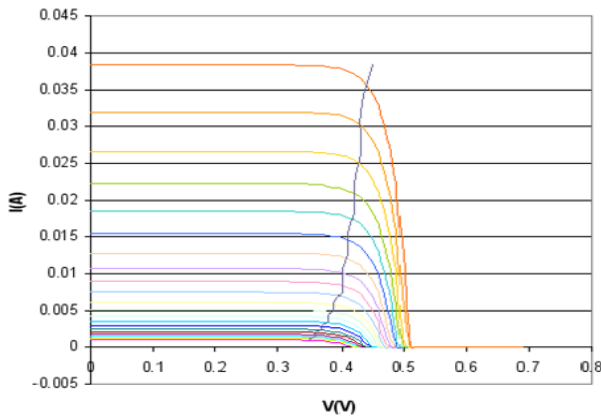

Fig. 5: Solar VI Curve in Varying Sunlight.

5. Experimental verification

The main aim is to verify the flexibility of power flow among the three-port converter connected to AC load and AC grid. Repeating sequence generator in series with a 5.5Ω resistor to implement a PV panel of 17V. For simplicity a sequence of 19, 24,15,1 is used, two batteries (DiaMec DM12V-7.2A) tanks are used to the storage element (36V) is obtained by using two battery (DiaMec DM12V-7.2A) tanks. Battery capacity is evaluated using its voltage, as voltage and State of Charge of battery are closely related. Capacitor C1, C2 and C3 are made 100uF and capacitor C4, C5 and C6 are made 1nF. The inductor L1 is made 170uH. The switching frequency of MOSFETs (IRF540N) is kept at 20 kHz.

The control algorithm first senses the voltage and current of the three ports, and then checks the availability of PV and loads ON, OFF conditions, then switch ON the suitable switches for the required mode of operation.

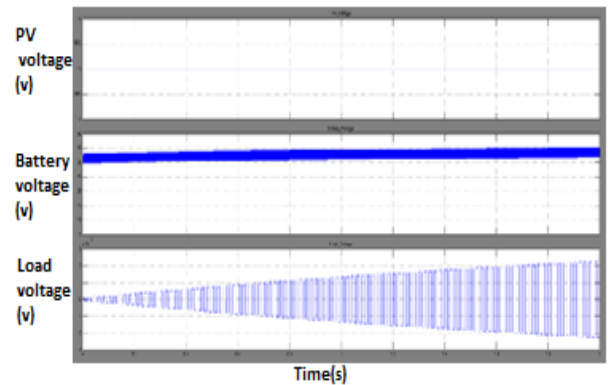

Fig. 6: Voltages of PV Panel, Battery and Load at Load off Condition.

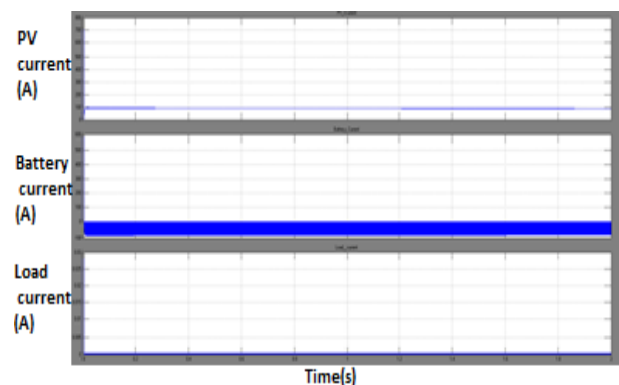

Fig. 7: Current through PV Panel, Battery and Load at Load off Condition.

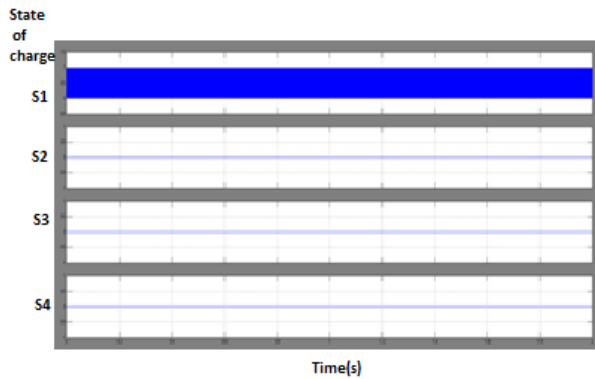

Fig. 8: Status of Switches S_1 , S_2 , S_3 , S_4 at Load off Condition.

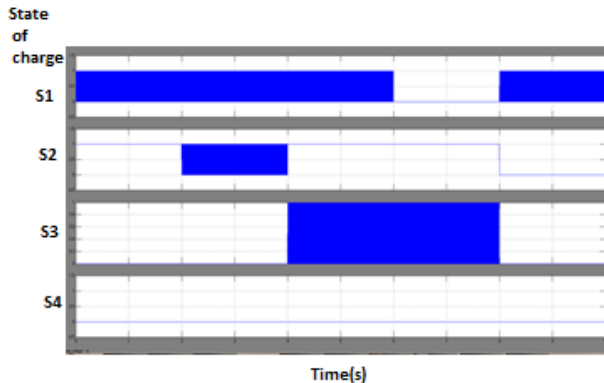

Fig. 9: Status of Switches S_1 , S_2 , S_3 , S_4 at Load on Condition.

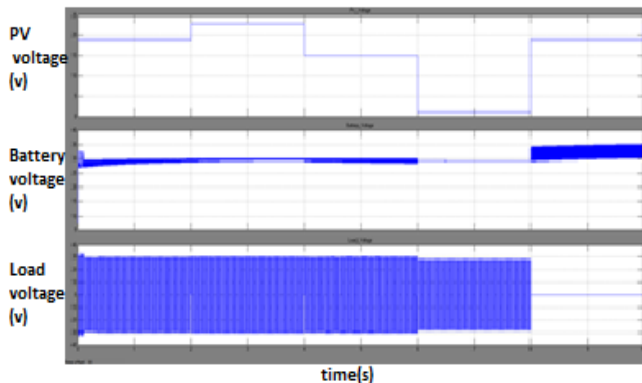

Fig. 10: Voltages of PV Panel, Battery and Load at Load on Condition.

At load off condition, no current flows through the load, the voltage across the load raises to maximum voltage from zero volt. The supply from PV panel is used to charge battery, and the Battery State of Charge increases. The topology operates in mode 4. Switch S_1 is kept ON as long as the PV is capable of supplying energy. C_4 is used for ZVS of S_1 . Fig 8 Shows the power flow operation when the load is ON. The supply voltage is 19V, hence the topology operates in mode 1 supplying the load. After 2 seconds the supply voltage increases to 24V, the excess voltage gets charges battery which can be used as back up. Now the PV is capable of running the load and charging the battery simultaneously. The topology operates in mode 2. Again, the supply voltage and decreases to 15V. As the supply voltage wont, be efficient for running the load, the remaining needed power is supplied from battery, thus the converter operates in mode 5. At 6th second, its becomes cloudy and hence there is no supply from PV panel. Now the converter operates in mode 6, and the battery act as back up for running the load. During these modes the inverter-rectifier converter act as inverter, and changes the DC power to suitable required AC power. When there is no load, the supply from PV charges the battery.

6. Conclusion

Thus, an effective power flow can be attained by using a single inductor integrated in three port converters between the source, battery and load. By neglecting the transformers and full-bridge converter, the system becomes compact and Switching losses are be minimized by implementing Zero voltage crossing technique. The efficiency is further increased by controlling through variable step size P&O algorithm. The experimental verifications also show the efficient optimization of photovoltaic energy in all six modes and all the modes becomes easily reconfigurable when using single inductor.

References

- [1] J. Lee, B. Min, D. Yoo, R. Kim, and J. Yoo, "A new topology for PV DC/DC converter with high efficiency under wide load range," in Proc. European Conf. Power Electron. Appl., Sept. 2007, pp. 1-6.
- [2] N. Zhang, D. Sutanto and K. M. Muttaqi, "A review of topologies of three-port DC/DC converters for the integration of renewable energy and energy storage system." *Renewable and Sustainable Energy Reviews*, 56: 388-401, 2016.
- [3] Y. J. Moon, Y. S. Roh, J. C. Gong and C. Yoo, "Load-Independent Current Control Technique of a Single-Inductor Multiple-Output Switching DCDC converter," *IEEE Transactions on Circuits and Systems II: Express Briefs.*, 59(1): 50-54, 2012.
- [4] K. S. Seol, Y. J. Woo, G. H. Cho, G. H. Gho and J. W. Lee, "A Synchronous Multioutput Step-Up/Down DCDC Converter with Return Current Control," *IEEE Transactions on Circuits and Systems II: Express Briefs.*, 56(3): 210-214, 2009.
- [5] D. D. Gaikwad; M. S. Chavan; Gaikwad "Wireless Computing and Networking (GCWCN)", 2014 IEEE Global Conference on 22-24 Dec. 2014, PoD ISBN: 978-1-4799-6299-0.
- [6] C. Lohmeier, J. Zeng, W. Qiao, L. Qu, and J. Hudgins, "A current-sensorless MPPT quasi-double-boost converter for PV systems," in Proc. IEEE Energy Convers. Congr. Exposit. Sept. 2011, pp. 1069-1075.
- [7] M. Aamir, S. Mekhilef and H. J. Kim, "High-gain Zero-Voltage Switching Bidirectional Converter With a Reduced Number of Switches," *IEEE Transactions on Circuits and Systems II: Express Briefs.*, 62(8):816-820,2015.
- [8] Abhishek Kumar Gupta, Ravi Saxena, "Review on widely-used MPPT techniques for PV applications", *Innovation and Challenges in Cyber Security (ICICCS-INBUSH)*, Feb. 2016.
- [9] Marin-Leonard Florea, Adrian Băltăţanu, "Modeling photovoltaic arrays with MPPT Perturb & Observe algorithm", *Advanced Topics in Electrical Engineering (ATEE)*, May, 2013.
- [10] Chee Wei Tan, Tim C. Green, Carlos A. Hernandez, "Analysis of Perturb and Observe Maximum Power Point Tracking Algorithm for Photovoltaic Applications", *Power and Energy (PECon 08)*, December. 2008.
- [11] Tian cheng, Dylan Dah-Chuan Lu "Non-Isolated DC-DC Converter with fully reconfigurable structure for renewable energy application", *IEEE*, 2017.
- [12] H. I. Abdelkader, A. Y. Hatata, M. S. Hasan, "Developing Intelligent MPPT for PV Systems Based on ANN and P&O Algorithms", *International Journal of Scientific & Engineering Research*, Volume 6, Issue 2, Feb. 2015.
- [13] Jianw Zeng, Wei Qiauo, Liyan Qu" An isolated three-port bidirectional DC-DC converter for Photovoltaic System with energy storage", DOI 10.1109/TIA.2015.2399613, *IEEE*.
- [14] Rajesh, K.S., Dash, S.S., Bayinder, Sridhar, R., Rajagopal, R."Implementation of an adaptive control strategy for solar photo voltaic generators in microgrlds with MPPT and energy storage" (2017) 2016 IEEE International Conference on Renewable Energy Research and Applications, ICRERA 2016, art. No. 7884439, pp. 766-771. DOI: 10.1109/ICRERA.2016.7884439.