

Open switch fault detection technique of a back-to-back converter using NPC topology for turbine systems

S. Mahaboob Basha ^{1*}, M. Kannan ²

¹ Assistant Professor, Department of Electronics and Communication Engineering, Velammal Engineering College Chennai, India.

² Associate Professor, Department of Electronics Engineering, MIT, Anna University Chennai, India.

*Corresponding author E-mail: phoenix_basha@yahoo.com

Abstract

Efficiency is turning into more and more necessary in power electronics. New applications are developed to reduce the consumption of energy. Inverters that supply continuous quality power have vast use in solar energy based applications. For a Wind Turbine Generation system with neutral-point-clamped (NPC) topology in a back to back converter, good efficiency is provided when operated at high power. In NPC topology totally twelve switches are present. Input current distortion, torsion vibration and output current distortion is caused by open switch fault within NPC inverter and rectifier of the consecutive converter. Wind Turbine Generation systems will be erroneous due to such faults. Open-switch fault detection methodology is necessary for consecutive converters for enhancing the output of Wind Turbine Generation systems. Our proposed work checks NPC rectifier and inverter for outer and inner open switch faults. Additionally for all the possible open-switch faults, a novel open-switch fault detection methodology within the back to back converter has been presented in this paper.

Keywords: Current Distortion; NPC Inverter; NPC Rectifier; NPC Technology; Open-Switch Fault.

1. Introduction

In the input side of a converter AC/DC Space vector PWM based device, variable voltage is converted to DC voltage. It is given as input to the Load-side inverter. An undetected fault in AC/DC SVPWM converter reduces the system stability and performance. Critical secondary faults may be caused due to such faults in switches which results not only in unbalanced AC input currents but also harmonics and distortions. Open-switch and Short-switch faults are the major reasons for power switch failure. The former generates associate unbalanced over current which disrupts the system. Hence while handling costly devices short switch fault has to be curbed. The latter faults are caused by thermal cycling. It results in lifting of bonding wires due to which fault occurs. Another factor causing open-switch fault is high collector current. Another main factor for such fault is gate driver failure. These faults in the grid-side inverter or in the generator-side convertor results in the interruption of energy supplied to the grid. Fuses and logic gate breakers provide a passive protection. But they disconnect the power sources resulting in hindrance for continuous supply of power.

2. Back-to-back converter in neutral point topology

Due to the fact that a large number of effective Back-to Back converters inheriting NPC topology are being developed recently, they are used in many high power and medium voltage applications like rolling mills, multi speed drives, renewable energy applications and also for power compensation. The most commonly used converter is Diode Clamped which incorporates NPC topology in it. Diode Clamped Multi-level Inverters

provide high quality output with reduced harmonic distortion, minimum harmonic stress and nearly curved undulation in output.

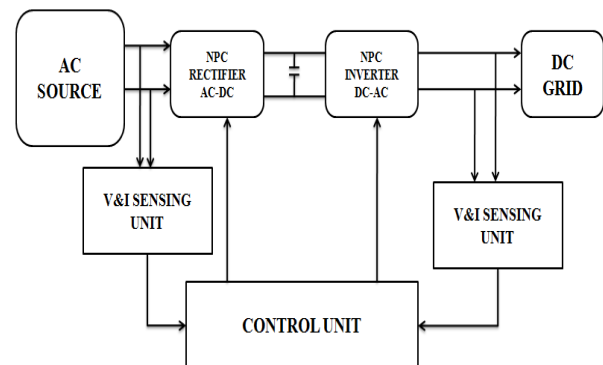

Fig. 1: Proposed Block Diagram.

Back-to-Back converters are employed in wind turbine generation (WTG) systems that are used for power conversion. Three Phase power from source to the load is transmitted using this converter. Three topologies are there in Back to Back converters. Even though it is expensive, it is of high necessity for high and medium-power Renewable Energy systems due to its high quality. Reduced collector-emitter voltage (VCE) and Minimum current distortion can be obtained using Multi-level topologies. Figure 1 shows neutral-point-clamped (NPC) topology used in a back back-to-back power converter.

3. Back-to-back converter

- Line side converter can generate sinusoidal line currents.

- DC-Link voltage regulates the power flow to AC grid
- Output power increases over the rated power if inverter is working as boosted DC-Link.
- Power grid is fed back with the braking energy, thereby avoiding wastage of power in braking resistors.
- Back-to-Back converter salient features are,
- It provides efficient power flow control between generation and Grid.
- Due to fast flow control to grid, the D.C. Link voltage held constant.
- Thus, capacitor size is reduced and inverter performance is also not affected.

3.1. Clamped diodes

The function of clamped diode utilized in the Neutral Point Clamped topology is as follows,

- Diode acts as a switch.
- Reduces the switching losses.
- D1 & D2 is freewheeling diode which provides forced commutation.

3.2. Advantages

- Harmonic distortion is reduced if higher voltage levels are used.
- Stress is minimal on motor bearings for smaller Voltages.
- Clamping diodes are used in medium rated semi-conductor which limits the voltage to one capacitor voltage level across the OFF-state switching device and are compatible for high voltage and high level applications.

3.3. Applications

- Adjustable speed drives
- Reactive power compensation
- Used to integrated several inputs (e.g.:-Solar, wind, etc.,)

4. Space vector PWM (pulse width modulation) [three levels]

A simple modulation algorithm (Space Vector PWM) is used in interpreting the phase voltage references (phase to neutral) into modulation times/duty-cycles that are applied to the PWM peripheral, where phase voltage references are returned from the controller. Though Space Vector PWM technique has been developed for control, this technique is widely used for any kind of three-phase load. SV-PWM makes use of the "nearest" vectors in addition to maximizing the DC bus voltage exploitation, which leads to the decrease of harmonic content.

4.1. Selection of electronic devices

The selection of component for three levels Neutral Point Clamped/Diode Clamped Multilevel Inverter is as shown in table column below,

m = Number of level

k = 0, 1, 2, $m-2$

Sl.No.	Description	Formulae	Calculation	3-Level NPC
1	Number of switching devices	$2(m-1)$	$2(3-1) = 4$	4 switches /phase
2	Blocking Voltage " V_b "	$(m-1) \cdot K$ $(m-1)$	$(3-1) \cdot 0 = 1$ $(3-1)$	$V_b = 1 \text{ V}$
3	Number of Clamping Diodes	$(m-1)(m-2)$	$(3-1)(3-2) = 2$	2 Diodes/Phase

Fig. 1: Selection of Component for 3-Level NPC/DCMLI.

4.2. Neutral point clamped rectifier

The ac-dc conversion is employed more and more for a large range of applications: power conversion techniques, microelectronics power supplies, electrical appliances including household devices, charging of battery, electronic ballasts, drives in dc motor, etc. Diodes are used by the best line commutated converters for ac-dc conversion that is to remodel the current from ac to dc. To scale back the harmonics from the supply and in order to obtain unity power factor, the method of analysis of 3 phase neutral point active rectifier has been proposed. By using SVPWM techniques the DC link voltage regulator provides line current command that results in controlling an output power estimator. To trace back this line current, hysteresis current controller is involved. The capacitor voltage compensator plays an important role in balancing the neutral point voltage.

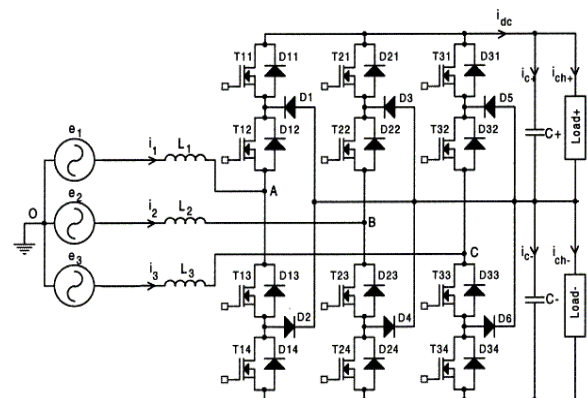

Fig. 2: Neutral Point Clamped Rectifier Including Three Levels.

From three-phase power lines, at unity power factor to obtain nearly sinusoidal currents, "a AC/DC converter with high frequency, minimum harmonic distortion and unity power factor" has been proposed. By adjusting the relative position of fundamental component of an optimized PWM (Pulse Width Modulation) typed voltage with respect to the supply voltage, control over the poor factor can be achieved. To achieve low harmonic distortion, constant dc bus voltage, balanced neutral point voltage and unity power factor, a controlled algorithm has been proposed. In our proposed rectifier, four power switches are used to generate the three-level SVPWM wave form on the rectifier terminal voltage. High voltage pattern generated by making use of harmonic contents and low voltage stress devices reduction are considered the major advantages of this adopted rectifier. For tracking the line current command, the hysteresis current controller technique as shown by figure 2 was employed and for the neutral point voltage balancing, a capacitor voltage compensator was used. Hence, power factor is improved and harmonic contents have been reduced.

For compensating the dc-link capacitors voltages fluctuations, a method on the basis of considering the modulation of the input current amplitudes was employed.

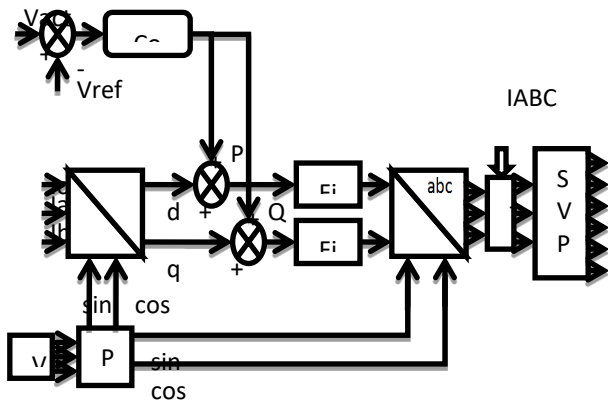

Fig. 3: Control Technique Used For Creating the Pulses for NPC Topology.

converter, the unstable behavior exhibited by the neutral point voltage which in all operating conditions should be completely avoided, here a correct capacitor voltage sharing is possibly achieved even under no-load condition since all the voltage fluctuations of the dc link capacitor has been compensated in a neutral point clamped active rectifier although the conventional method fails.

4.3. Neutral point clamped inverter

In the event of wherever the reference voltage is used in a diagrammatic way as a reference vector to be generated by the power converter, the technique employed is Space Vector Modulation. In the three inverter operation, 3 switching states are present for every inverter leg; [N], [P] and [O]. [N] signifies that the lower 2 switches in leg A are on with the value of terminal voltage equal to $-V_{dc}/2$, while [P] implies that the higher 2 switches in leg A are on with the value of inverter terminal voltage, V_{AN} equal to $+V_{dc}/2$, and the inner 2 switches denoted by the switching state [O] are on with the value of zero terminal voltage. A total of 27 combination of shift states for NPC inverter are present.

A 3-level neutral point clamped inverter is shown in Fig. 4. And it includes twelve shift devices that are conjointly supplied with 2 capacitors which are serially connected, each capacitor charged with VDC. Between these two capacitors the point present is known as DC-voltage neutral point. 2 clamping diodes and 4 shift devices (IGBT's) connected in series are comprised in each phase leg. At zero, their role includes clamping of the 6 middle switches potential to DC-link purpose. The three-level output voltage is provided by the predefined specific combos of the 12 switches.

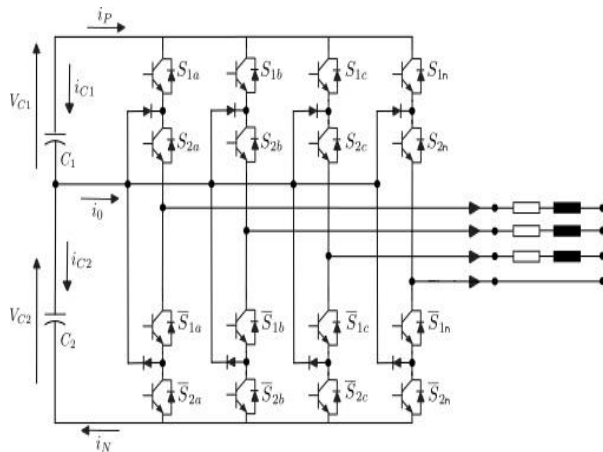

Fig. 4: A 3-Phase Neutral Point Clamped Inverter with 3-Levels.

In one phase leg at a time only 2 among 4 switches will be turned on, so with respect to the change states P, N and O the DC-link points connected to the switches are delineated, which denotes that

there could be creation of 3 voltage levels exploitation O since the reference.

S_{1x}	ON	OFF	OFF
S_{2x}	ON	ON	OFF
S_{3x}	OFF	ON	ON
S_{4x}	OFF	OFF	ON
V_{x0}	V_{DC}	0	$-V_{DC}$
Switching State	P	O	N

Fig. 2: Switching States and Switching Combination for 3-Level Inverter (Considering One Phase-Leg).

5. Switching of states

There are about twenty seven switching states included for a 3-level three-phase inverter. The association between a wide range of DC-link points are represented by these states. Consider that a load is connected to the output of those states, which leads to an output phase voltage generated by the inverter, which follows the calculation mentioned below:

Sl.No.	Switching States			Corresponding Voltage Vectors		
	a	b	c	Vector	Magnitude	Angle
1	P	P	P	V_0	0 V	0
2	O	O	O			
3	N	N	N			
4	P	O	O	V_1	$\frac{2}{\sqrt{3}}V_{DC}$	0
5	O	N	N			
6	P	N	N	V_2	$-V_{DC}$	0
7	P	O	N	V_3	$\frac{2}{\sqrt{3}}V_{DC}$	$\frac{\pi}{6}$
8	P	P	O	V_4	$\frac{2}{\sqrt{3}}V_{DC}$	$\frac{\pi}{3}$
9	O	O	N			
10	P	P	N	V_5	$-V_{DC}$	$\frac{\pi}{3}$
11	O	P	N	V_6	$\frac{2}{\sqrt{3}}V_{DC}$	$\frac{\pi}{2}$
12	O	P	O	V_7	$\frac{2}{\sqrt{3}}V_{DC}$	$\frac{2\pi}{3}$
13	N	O	N			
14	N	P	N	V_8	$-V_{DC}$	$\frac{2\pi}{3}$

Fig. 3: Switching States and Switching Combination for A three (Three)-Level Inverter.

15	N	P	O	V_9	$\frac{2}{\sqrt{3}}V_{DC}$	$\frac{5\pi}{3}$
16	O	P	P	V_{10}	$\frac{2}{\sqrt{3}}V_{DC}$	
17	N	O	O			
18	N	P	P	V_{11}	$-V_{DC}$	
19	N	O	P	V_{12}	$\frac{2}{\sqrt{3}}V_{DC}$	$-\frac{5\pi}{3}$
20	O	O	P	V_{13}	$\frac{2}{\sqrt{3}}V_{DC}$	$-\frac{2\pi}{3}$
21	N	N	O			
22	N	N	P	V_{14}	$-V_{DC}$	$-\frac{2\pi}{3}$
23	O	N	P	V_{15}	$\frac{2}{\sqrt{3}}V_{DC}$	$-\frac{\pi}{2}$
24	P	O	P	V_{16}	$\frac{2}{\sqrt{3}}V_{DC}$	$-\frac{\pi}{3}$
25	O	N	O			
26	P	N	P	V_{17}	$-V_{DC}$	$-\frac{\pi}{3}$
27	P	N	O	V_{18}	$\frac{2}{\sqrt{3}}V_{DC}$	$-\frac{\pi}{6}$

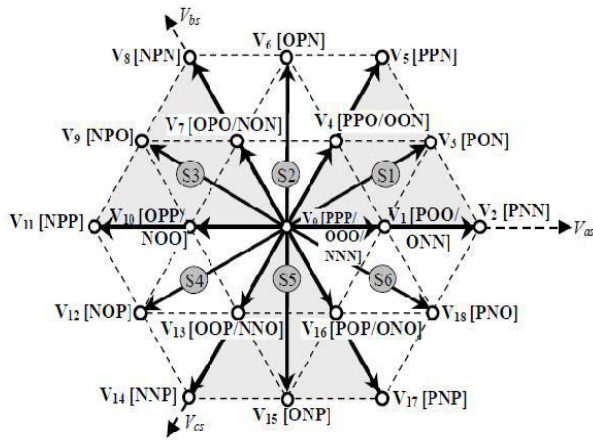

Fig. 5: Diagram Demonstrating Space Vector for A three (Three)-Level Inverter.

Reference vector is found using the 3 voltage vectors same as that of the 2-level inverter. In addition, by dividing each sector into 4(four) regions for the 3-level converter, more specific output can be obtained. The voltage vectors on the basis of magnitude are defined as:

- Zero Voltage Vectors(ZVV)
- ZVV: $V=0$ (redundant sw states)
- Small Voltage Vectors(SVV)
- SVV: $V=1,4,7,10,13,16$ (redundant sw states)
- Medium Voltage Vectors(MVV)
- MVV: $V=3,6,9,12,15,18$
- Large Voltage Vectors(LVV)
- LVV: $V=2,5,8,11,14,17$

5.1. Working of SVM

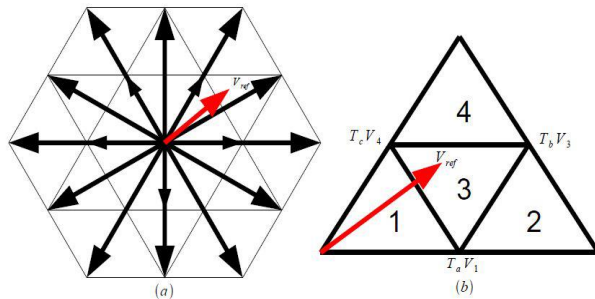

Fig. 6: Diagram Depicting Space Vector for (A) All Sectors (B) Sector 1.

For sector 1

$$V_{\alpha} + \frac{\sqrt{3}}{3} V_{\beta} - \frac{V_{DC}}{3} < 0 \tag{1}$$

The selection of region is done. In case of not true, then the vector can be in region 2:

$$V_{\alpha} - \frac{\sqrt{3}}{3} V_{\beta} - \frac{V_{DC}}{3} > 0 \tag{2}$$

In case if the above both are not true, the region 3 could contain the vector:

$$V_{\alpha} - \frac{\sqrt{3}}{6} V_{\beta} < 0 \tag{3}$$

In case none of the above are true, the 4th region contains the vector

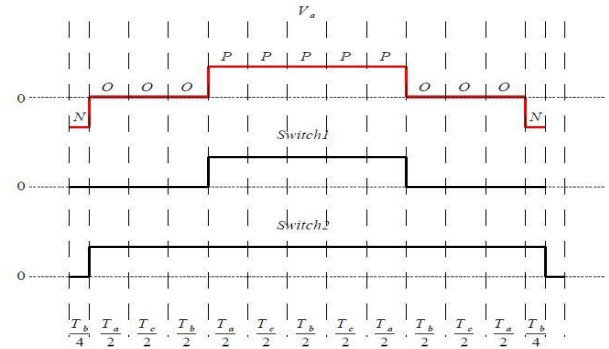

Fig. 7: Switching States Sequence Represented By Waveform For Switches 1 And 2 In Sector 1, Region 1, R-Phase.

The switches 1 and 2 sequencing in even sectors, i.e. 2,4,6 results in opposite waveform (beginning with 1 to 0 and again to 1) which cannot be compared with the ramp signal. In this case the waveform represented for switch 3 and 4 are utilized for these sectors, since they can produce the switch 1 and 2 complementary waveform. Further, the conversion of the output information is possible, after the comparison of the waveform with that of the ramp, which gives the switching information in even sectors for switch 1 and 2.

6. Simulation result

Open-switch and Short-switch faults are the two general types of power switch failures. The generation of an unbalanced or unstable over current from a short-switch fault can lead to damages caused in different necessary system devices. Thus, this fault ought to be immediately detected to guard devices that are overpriced. Open switch fault can occur because of many reasons. Bonding wires are lifted due to thermal which successively results in the occurrence of an open-switch fault. [24]

Another reason causing open-switch fault is large collector current. Also, the gate driver circuits failure forms one of the major and common causes that produces open-switch faults. The energy supply to the grid is reduced in case of any kind of open-switch faults occur either in a grid-side inverter or in an exceedingly generator-side converter. Fuses also called as circuit breakers are used for the devices passive protections. Such passive protections suddenly stops the continuous operation and causes the power sources to be disconnected.

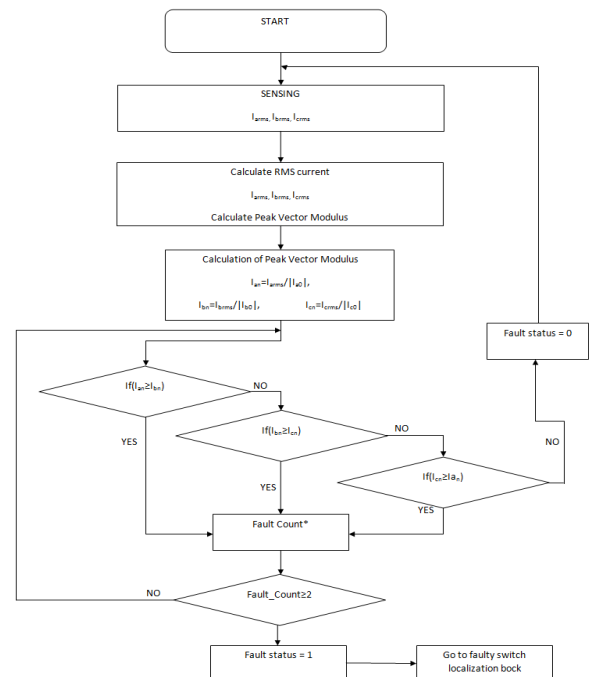

Fig. 8: Diagram Showing Open Switch Fault Detection Algorithm.

Open-Switch Fault Detection Method of a Back-to-Back Converter Using NPC Topology for Wind Turbine Systems

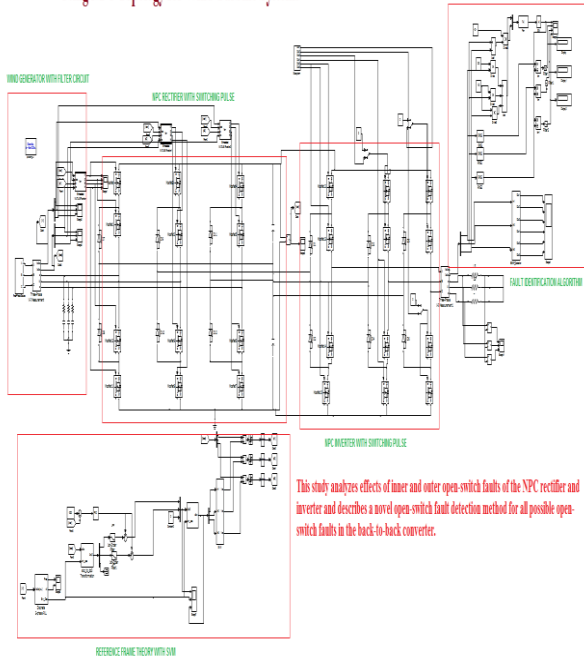

Fig. 9: Simulation Implementation of the Npc Back-To-Back Converter.

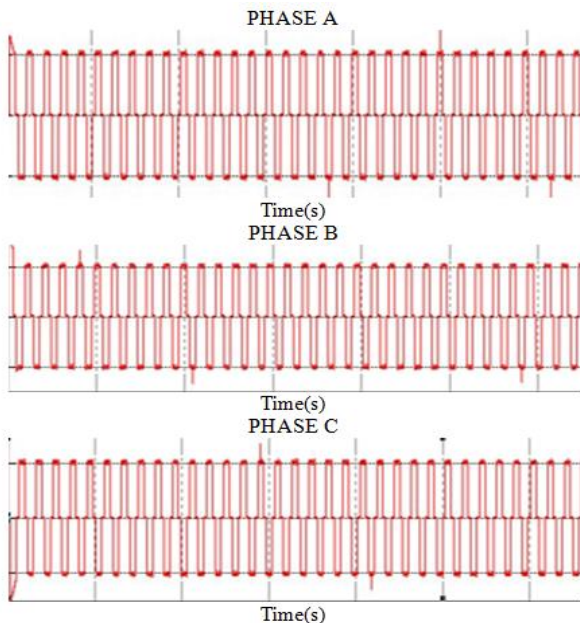

Fig. 10: Inverter Output At Without Fault Condition.

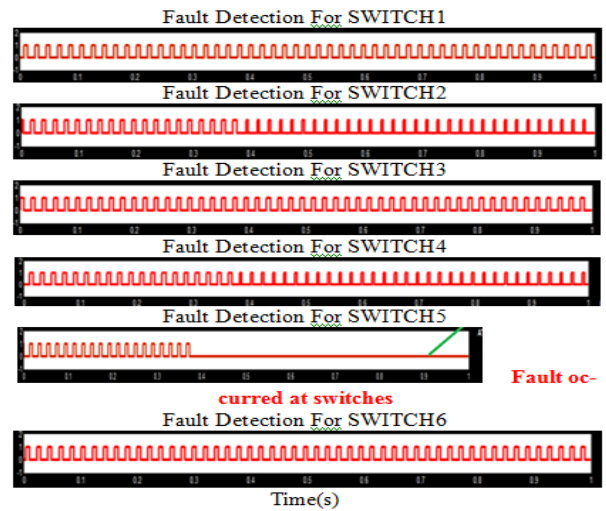

Fig. 11: Inverter Output at with Fault Condition.

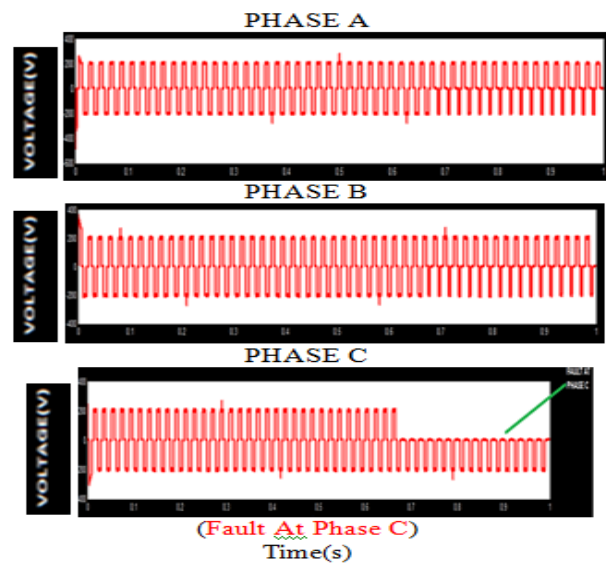

Fig. 12: Fault Occurrence In The Switch Open Switch Fault Occurs In The Switches.

7. Conclusion

Considering this paper, 3-Phase R-Load and a 3-Phase AC Power Supply comprises the simulation. Changes of the current pattern can occur due to the fault of an open-switch which in turn can lead to generation of secondary problems causing break down of the other parts. Therefore, the faults of open switch must be detected, thus preventing the other components destruction and these systems reliability are also maintained. The output of the NPCTopology and open switch faults detection contained in inverter section are also discussed in this paper.

on bookmarks will be removed from papers during the processing of papers for publication. If you need to refer to an Internet email address or URL in your paper, you must type out the address or URL fully in Regular font.

References

- [1] Zeng, Z., Zhao, R., Yang, H., et al.: 'Topologies and control strategies of multi-functional grid-connected inverters for power quality enhancement: A comprehensive review', *Renew. Sustain. Energy Rev.*, 2013, 24, pp. 223–270.
- [2] Fan, L.L., Miao, Z.X.: 'Mitigating SSR using DFIG-based wind generation', *IEEE Trans. Sustain. Energy*, 2012, 3, (3), pp. 349–358.
- [3] Zeng, Z., Yang, H., Tang, S., et al.: 'Objective-oriented power quality compensation of multi-functional grid-tied inverters and its application in micro-grids', *IEEE Trans. Power Electron.*, 2015, 30, (3), pp. 1255–1265.
- [4] Tummuru, N.R., Mishra, M.K., Srinivas, S.: 'Multifunctional VSC controlled microgrid using instantaneous symmetrical components theory', *IEEE Trans. Sustain. Energy*, 2014, 5, (1), pp. 313–322.
- [5] Zeng, Z., Yang, H., Guerrero, J.M., et al.: 'Multi-functional distributed generation unit for power quality enhancement', *IET Power Electron.*, 2015, 8, (3), pp. 467–476.
- [6] Dai, N.Y., Zhang, W.C., Wong, M.C., et al.: 'Analysis, control and experimental verification of a single-phase capacitive-coupling grid-connected inverter', *IET Power Electron.*, 2015, 8, (5), pp. 770–782.
- [7] Vasquez, J.C., Mastromauro, R.A., Guerrero, J.M., et al.: 'Voltage support provided by a droop-controlled multifunctional inverter', *IEEE Trans. Ind. Electron.*, 2009, 56, (11), pp. 4510–4519.
- [8] Sawant, R.R., Chandorkar, M.C.: 'Methods for multi-functional converter control in three-phase four-wire systems', *IET Power Electron.*, 2009, 2, (1), pp. 52–66.
- [9] Mahdianpoor, F.M., Hooshmand, R.A., Ataei, M.: 'A new approach to multifunctional dynamic voltage restorer implementation for emergency control in distribution systems', *IEEE Trans. Power Deliv.*, 2011, 26.
- [10] Singh, M., Khadkikar, V., Chandra, A.: 'Grid synchronisation with harmonics and reactive power compensation capability of a permanent magnet synchronous generator-based variable speed wind energy conversion system', *IET Power Electron.*, 2011, 4, (1), pp. 122–130.
- [11] Todeschini, G., Emanuel, A.E.: 'Wind energy conversion systems as active filters: Design and comparison of three control methods', *IET Renew. Power Gener.*, 2010, 4, (4), pp. 341–353.
- [12] Zeng, Z., Zhao, R., Yang, H., et al.: 'Topologies and control strategies of multi-functional grid-connected inverters for power quality enhancement: A comprehensive review', *Renew. Sustain. Energy Rev.*, 2013, 24, pp. 223–270.
- [13] M. Mobarrez, M. G. Kashani, G. Chavan, and S. Bhattacharya, "A Novel Control Approach for Protection of Multi-Terminal VSC based HVDC Transmission System against DC Faults," in *ECCE 2015-Energy Conversion Congress & Exposition, Canada, 2015*, pp. 4208- 4213.
- [14] Wang, F., Duarte, J.L., Hendrix, M.A.M.: 'Grid-interfacing converter systems with enhanced voltage quality for microgrid application-concept and implementation', *IEEE Trans. Power Electron.*, 2011, 26, (12), pp. 3501–3513.
- [15] Han, B., Bae, B., Kim, H., et al.: 'Combined operation of unified power-quality conditioner with distributed generation', *IEEE Trans. Power Deliv.*, 2006, 21, (1), pp. 330–338.
- [16] Li, Y., Vilathgamuwa, D.M., Loh, P.C.: 'Microgrid power quality enhancement using a three-phase four-wire grid-interfacing compensator', *IEEE Trans. Ind. Appl.*, 2005, 41, (6), pp. 1707–1719.
- [17] Wu, T.F., Nien, H.S., Shen, C.L., et al.: 'A single-phase inverter system for PV power injection and active power filtering with nonlinear inductor consideration', *IEEE Trans. Ind. Appl.*, 2005, 41, (4), pp. 1075–1083.
- [18] Sawant, R.R., Chandorkar, M.C.: 'Power boundaries in multifunctional converter control for three-phase four-wire systems'. *Proc. IEEE Region 10 Annual Int. Conf.*, 2008, pp. 1–6.
- [19] Macken, K.J.P., Vanthournout, K., Van den Keybus, J., et al.: 'Distributed control of renewable generation units with integrated active filter', *IEEE Trans. Power Electron.*, 2004, 19, (5), pp. 1353–1360.
- [20] Zeng, Z., Zhao, R., Yang, H.: 'Coordinated control of multi-functional grid-tied inverters using conductance and susceptance limitation', *IET Power Electron.*, 2014, 7, (7), pp. 1821–1831.
- [21] Farghal, S.A., Kandil, M.S., Elmitwally, A.: 'Quantifying electric power quality via fuzzy modelling and analytic hierarchy processing', *IEE Proc. – Gener. Trans. Distrib.*, 2002, 149, (1), pp. 44–49.
- [22] Morsi, W.G., El-Hawary, M.E.: 'Power quality evaluation in smart grids considering modern distortion in electric power systems', *Electr. Power Syst. Res.*, 2011, 81, (5), pp. 1117–1123.
- [23] Salarvand, A., Mirzaeian, B., Moallem, M.: 'Obtaining a quantitative index for power quality evaluation in competitive electricity market', *IET Gener. Trans. Distrib.*, 2010, 4, (7), pp. 810–823.
- [24] Mohanraj, K., Paramasivam, S., Dash, S.S., Ramprasad, S. Analysis of DC bus fault and line faults on voltage source inverter fed induction motor(2013) *International Review on Modelling and Simulations*, 6 (6), pp. 1907-1913.