

Analyzing the power quality for smart grid with hybrid conventional resources.

Deepa Kumari ^{1*}, Sunny Vig ²

¹ ME student, EE, Chandigarh University, Mohali

² Asst Prof, EE Dept, Chandigarh University, Mohali

*Corresponding author E-mail: Deepanegi0849@gmail.com

Abstract

The upcoming advanced electric grid or smart grid is define as the intelligent junction of smart devices making a power system featured by the next level advancement of flow of information and electricity in two way. In this work we have come out with the better quality of energy generated at transmission side which also involves the implementation of fuzzy controller. As a goal this work is possessing working of any 2 non conventional resources i.e. wind and PV solar panel to run any non linear load by providing the controlled power to it through fuzzy controller. A general experimentation was performed to examine the current condition of art of smart grid, and removal of disturbances and their affect on power quality. Which is due to the complications, huge heterogeneity of smart grid and high amount of information to be processed, computational techniques are enabling technologies for its advancement and success in future. Hence the motive of this work is to implement fuzzy controller in combination with non conventional resources in smart grid to the production of needed amount of electricity to make the non linear load work accordingly. Different artificial technologies give support to the development of power system.

Keywords: Smart Grid; Artificial Intelligence; Fuzzy Controller; Conventional and Non-Conventional Resources.

1. Introduction

Conventional resources like Solar, Wind, Thermal, Hydro, Geothermal etc. are abundantly present in the environment. The renewable energy resources are found to be very important to build the ecofriendly, flexible and reliable power system. As we know that there is limitation of non renewable resources in the environment the concept of non conventional resources has grown as the revolution in power system[1] Evolution of non conventional sources is one of the results of this revolutionary act in the field of power system. Therefore it gives birth to the new and different ideas to balance the different non linear and linear loads. Implementation of renewable resources in place of non renewable sources also eliminates the present dependency of power system on fissile fuel. While satisfying the equilibrium between demand and supply. The considerable advantages of system formed by integrating the two renewable resources comprised of performance efficiency, system reliability, system flexibility etc [2]. Since the performance of wind and solar system are environmental dependent so by combining these two renewable sources and making a hybrid system can overcome this problem. This is likely to support that the separate hybrid generating systems are less costly and more consistent than the other power generation system that relay on a single supply of energy [11] [12].

At a quick glimpse, “revolution” could appear a very strong term to express the improvements in power grid technologies. But when you give a focussed view and you will find that the transformation from conventional grid to “smart” grids are nothing less than revolutionary [3] As per the (U.S Government’s International energy outlook 2008),it has been concluded that the consumption of energy worldwide is increased by 50% from 2004 to 2029. Hence there

should be no wonder that the upcoming electric grids should definitely fulfil the certain requirements that Tesla never imagined. Including the fact that the smart grid must be able to provide the power from multiple and widely distributed resources like solar cell system, wind turbines photovoltaic cells and also from plug in hybrid electric vehicles [13].

Now coming to the point of artificial intelligence, it can be described as the analysis and creation of computer system that can take several inputs and react to them. Artificial intelligent systems are designed to produce the intelligent machines. The intelligence should be shown by decisions making, thinking, problem solving, more importantly by learning. Artificial intelligence is an interdisciplinary field which demands the strong command in linguistics, computer science, psychology, philosophy, biology and so on for serious research [14] [15].

1.1. Planned hybrid energy system

Figure 1 represents the arrangement constriction of two renewable systems combined to form the hybrid system. And RES consists of wind turbine & solar panel. The wind power generation system consists of two or more metallic blades which are further connected to the wind turbine and the blades catches the winds kinetic energy which is coupled to generator [4]. And all the mechanical power collected by the wind turbines from the wind is formulated as:

$$P_m = 0.5\rho AC_p V_3$$

And the maximum power coefficient value in this case is 0.59. This is mainly depending upon the two factors “Tip Speed Ratio” (TSR) and “Pitch angle”. Turbine blades are united at an angle with respect to the longitudinal axis is called “Pitch Angle”. And the speed of

wind to the linear speed of rotor is called “Tip Speed Ratio”. In actual the maximum and minimum possible choice for full speed and slow speed turbines are 0.4 to 0.5 and 0.2 to 0.4 respectively. In solar system or Photovoltaic system, the solar cell is the basic component. When the solar arrays are connected in parallel or series for obtaining the essential voltage, high power and current they are known as the PV array [5]. P-N junction diode which is created by the semiconductor material is similar to the solar cell, it generates the current when at the junction light is absorbed by the photovoltaic effect

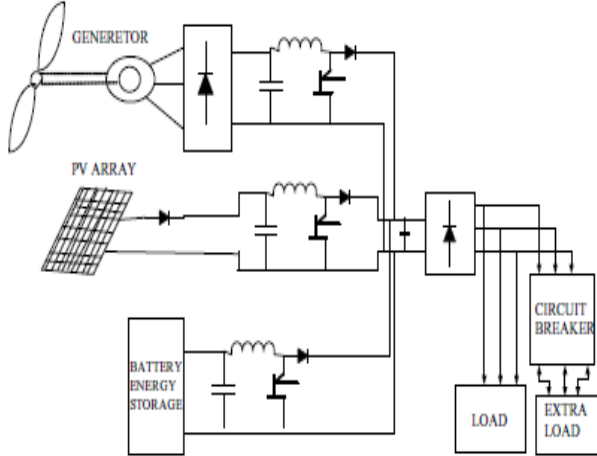

Fig. 1: Arrangement of Integrated Energy System.

Figure 1 represents the arrangement construction of two renewable systems combined to form the hybrid system. And RES consists of wind turbine & solar panel. The wind power generation system consists of two or more metallic blades which are further connected to the wind turbine and the blades catches the winds kinetic energy which is coupled to generator [4]. And all the mechanical power collected by the wind turbines from the wind is formulated as:

$$P_m = 0.5\rho AC_p V_3$$

And the maximum power coefficient value in this case is 0.59. This is mainly depending upon the two factors “Tip Speed Ratio” (TSR) and “Pitch angle”. Turbine blades are united at an angle with respect to the longitudinal axis is called “Pitch Angle”. And the speed of wind to the linear speed of rotor is called “Tip Speed Ratio”. In actual the maximum and minimum possible choice for full speed and slow speed turbines are 0.4 to 0.5 and 0.2 to 0.4 respectively. In solar system or Photovoltaic system, the solar cell is the basic component. When the solar arrays are connected in parallel or series for obtaining the essential voltage, high power and current they are known as the PV array [5]. P-N junction diode which is created by the semiconductor material is similar to the solar cell, it generates the current when at the junction light is absorbed by the photovoltaic effect

1.2. Hybrid power system modelling

This combined set of renewable resources i.e. hybrid system of wind and solar cell comprises of multiple stages of generation, converter/controller and the last stage of distribution. Her we have discussed the active simulation model of wind turbine and photovoltaic cell. The final model contains the PVcell, dc/dc amplifier converter to obtain the required amount of voltage at the receiving end, using wind turbine, dc/dc amplified converter, ac/dc diode rectifier along with MPPT [6]. The designed structure of explained system is displayed in figure 2.

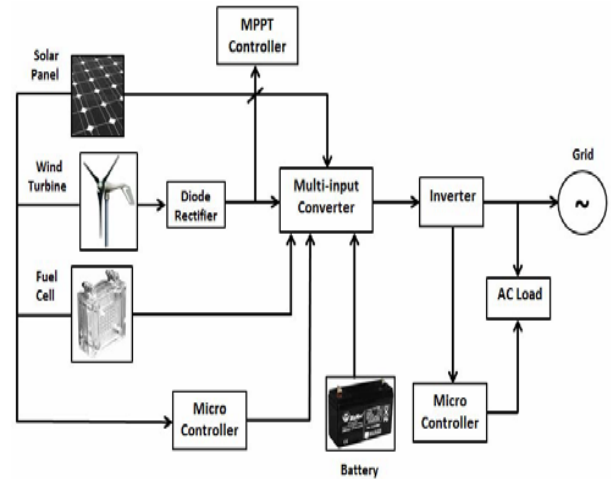

Fig. 2: Block Diagram of Hybrid System.

1.2.1. PV cell is modelling in MAT LAB, Simulink

General model present in mathematical lab is used by number of researchers. But in this work we have purposed the model of PV cell with two diodes and the diagram is displayed in fig.3.

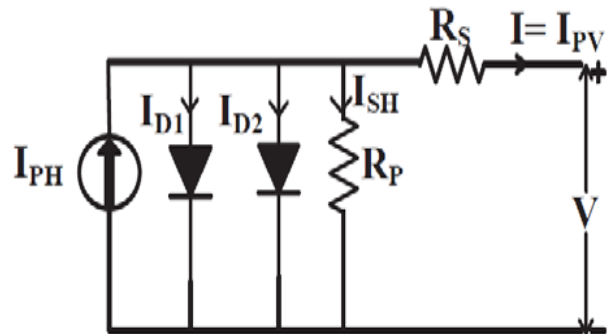

Fig. 3: Equivalent Circuit of PV Cell.

In the given table below the specification of solar panel in listed are implemented and used in the purposed hybrid power system.

Table 1: Specification of Solar Panel

| Specification Value | VALUE |
|---------------------------------|----------|
| Voltage output at maximum power | 1000V |
| peak power voltage | 600V |
| peak power current | 14.45 |
| Type and number of cell | 41 cells |
| Temperature Available | 90°C |

1.2.2 .Modelling of wind turbine in mat lab, Simulink

The permanent magnet synchronous generator is used among various type of wind turbines, because it has efficiency and higher reliability. The generated mechanical power from wind turbine and available power of wind energy system is described by equation stated below:

$$P_{wind} = \frac{1}{2} (\rho A V^3)$$

$$P_m = \frac{1}{2} (\rho A V^3 C_p \lambda \beta)$$

Where symbols have their meaning as, ρ represents is the density of air (kg/m^3), V gives the wind velocity (m/s), A represents the area of the turbine blades (m^2), and C_p is the coefficient of power. Effectiveness of the wind turbine to change wind energy into electrical energy is represented by coefficient of non linear function. And this depends upon two variables: Pitch angle and tip speed ratio (TSP). Pitch angle (β) is the angle at which the longitudinal axis aligned to the turbine blades. The TSP (λ) is the ration of the turbine angular speed over the speed of wind [10]

And the specification for the wind turbine is listed below.

Table 2: Specification of Wind Turbine

| Specifications | Value |
|--------------------|---------|
| Rated Power | 2000 W |
| Maximum Power | 2200 W |
| Nominal Voltage | 650 V |
| Initial Wind Speed | 2.0 M/S |
| Fixed Wind Speed | 10 M/S |

1.3. Maximum power point trackin

MPPT is generally implemented to get better the efficiency of the output power from the solar panel and wind turbine. In MPPT also includes different techniques. Some of the widely used techniques are: Fuzzy logic, incremental conductance method, neural networks, perturb and observe. Initially the reference voltages from both the wind turbine and photovoltaic array are adjusted and thus if the output from both sides is not be equal to their maximum power [8]. We require managing the starting values of reference in the direction output power and vice versa. This same process is set to repeat until the solar array and wind turbine reaches to the maximum power point. Characteristic representation of PV representation is shown in fig.5

If via MPPT techniques it comes under the crisis, then it gets the current I or voltage VMP the PV array should get the utmost output automatically under the available temperature and irradiance[9].

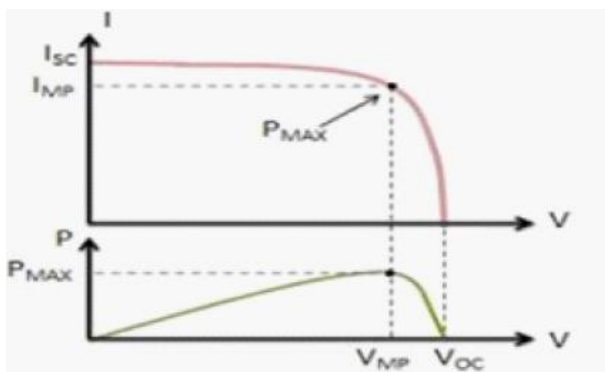

Fig. 5: Output Characteristics of PV Array.

1.4 Simulation model and discussion

The complete designed model with the fuzzy control schemes for the purposed hybrid generation is shown in fir.6. They carry some of the main parameters as:

Grid power resources line voltage is 220V and the frequency of line is 50 Hz

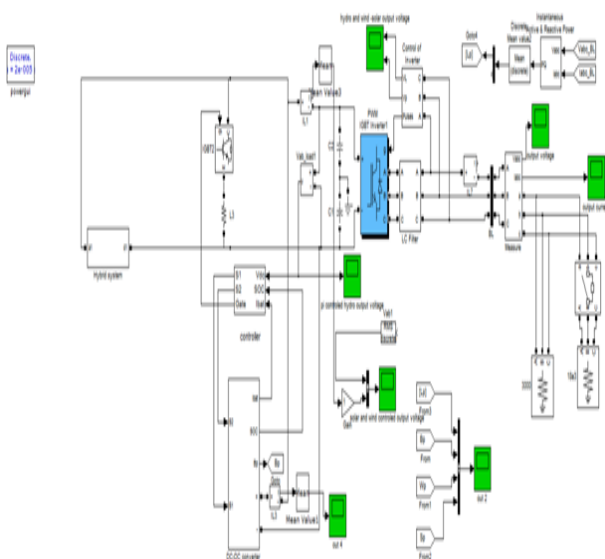

Fig. 6: Proposed Grid's Schematic Diagram Connected with PV/Wind System.

Different output current and voltage wave forms are shown in fig 7

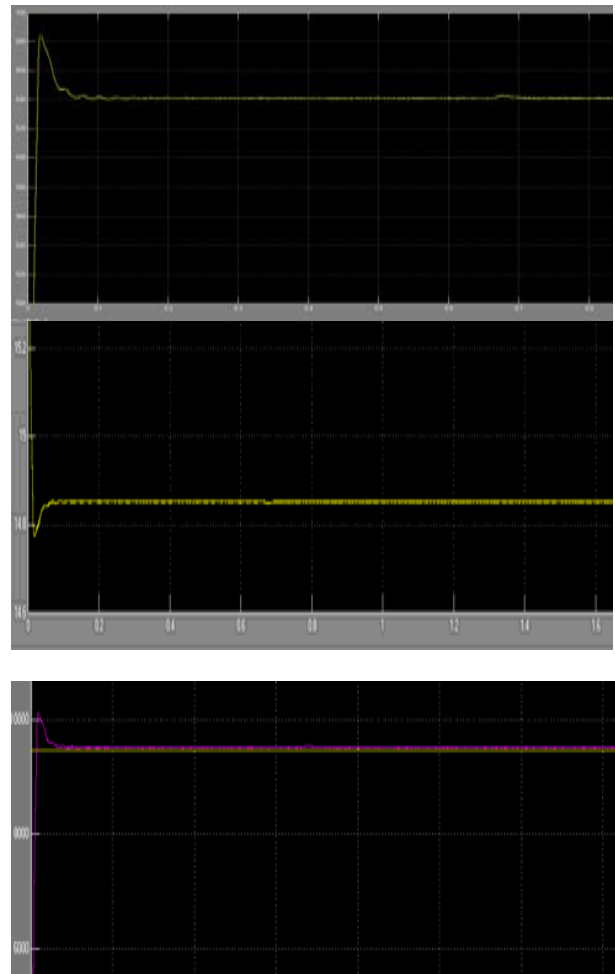
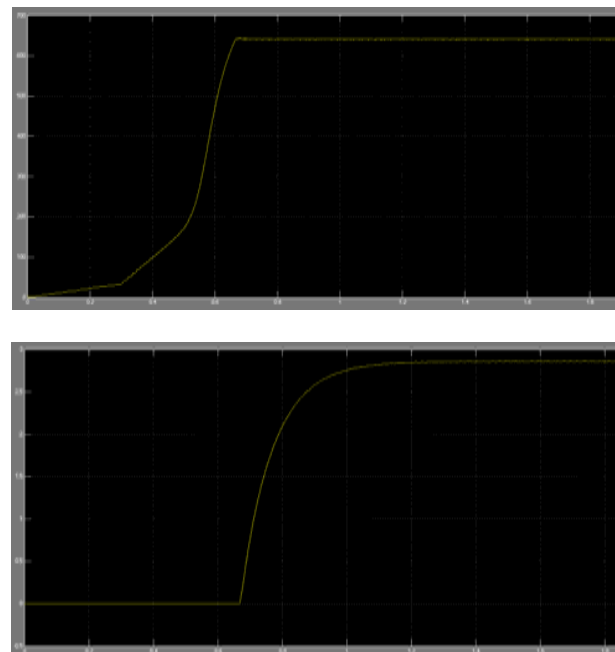

Fig. 7: Different Waveform of I) PV Voltage, II) PV Current, III) Maximum Power Output.

Different output voltage and current waveform are represented in fig 8 below



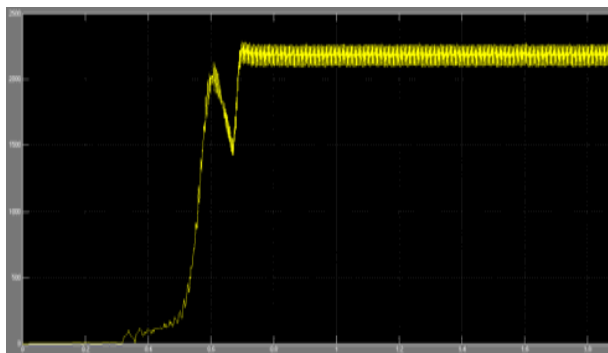

Fig. 8: Different Waveform of I) Wind Voltage II) Wind Current III) Wind Power.

Fig 9 below shows the PI controlled output waveform.

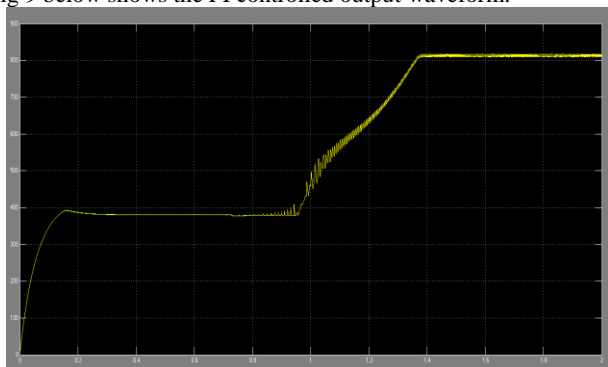

Fig. 9: PI Controller Output Power.

Fig 10 shows the combined controlled output of hybrid system.

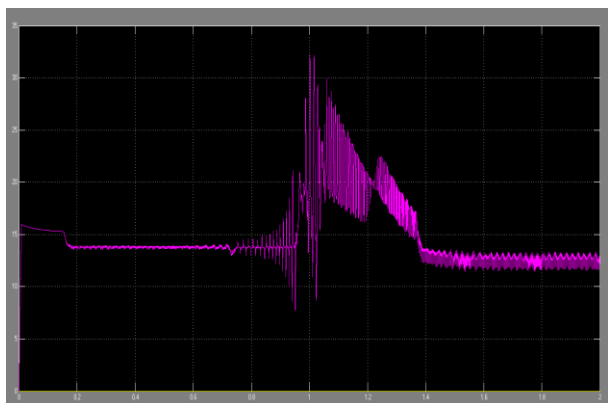

Fig. 10: Combine Controlled Output from Hybrid System.

Figure 11 & 12 displayed below are the output voltage and output current from the developed hybrid smart grid based fuzzy controlled system.

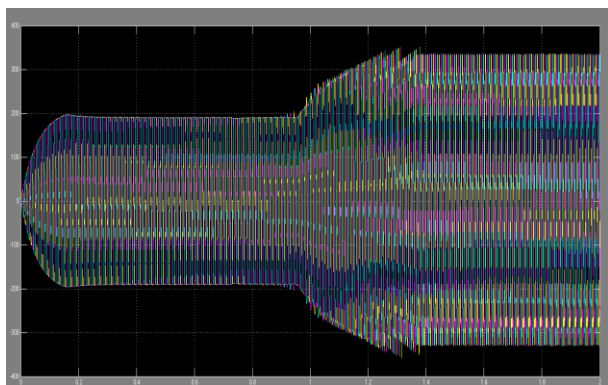

Fig. 11: Wave Form of Grid Output Voltage.

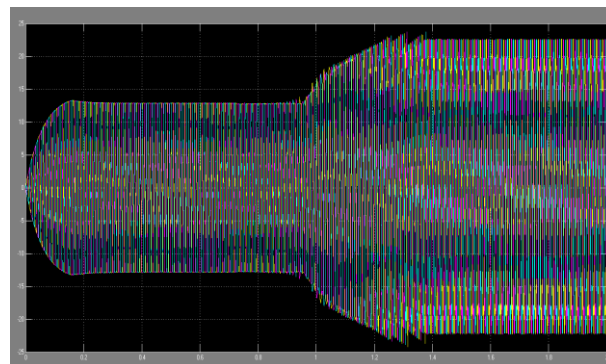

Fig. 12: Wave Form of Grid Output Current.

2. Conclusion

Smart Grid can revolutionarily be come to use to solve the current energy issues and problems. The whole arrangement of power system or the present state of network need to be develops i.e. transmission and consumption side requirements. To make all the desired properties work for the new technologies and optimal solution the research in still on. By the implementation of smart grid technology only the required amount of energy is used so that the energy is not wasted. This technology also helps to save the earth from global warming. It refers to the modernized version of the earlier traditional methods of energy supply. Smart meters, Smart Homes, Smart City and so would make the Smart Grid. As the new technologies would be invented and strengthened existing ones to the desired specifications meet the Smart Grid would be reality and change the whole pattern of energy in the world.

References

- [1] Dr. D. Devaraj and B. Kanagasakthivel, "Performance and Simulationstudy of Wind - Solar PV Hybrid Energy System Using MATLAB/Simulink", IEEE transaction on power electronics, May 2015.
- [2] Teena Jacob, Arun S, "Maximum Power Point Trackingof Hybrid PV and Wind Energy Systems Using a New Converter Topology", IEEE transaction on industrial electronics, Jan 2012.
- [3] The IEEE Emerging Technology portal, 2006—2012 Visit: <http://www.ieee.org/go/emergingtech>
- [4] Patel MR. Wind and solar power systems design analysis and operation. 2nd ed. Taylor and Francis Group Publishing Co. 2006; 30(3):265–6.
- [5] Anil Kumar Kashyap, Amit Agrawal et al. 2017 "Simulink of Hybrid low-power Wind Generationand PV grid connected system using MATLAB"
- [6] Witold and Pedrycz (1993) Fuzzy control and Fuzzy system (2 ed.). Research Studies press ltd.
- [7] K. Pavankumar Reddy* and M. Venu Gopala Rao et al.2015, "Modelling and Simulation of Hybrid Wind Solar Energy System using MPPT"Indian Journal of Science and Technology.
- [8] Gheydi M, Effatnejad R, Ramezanpour P. Evaluation of uncertainty in hybrid plants, including wind turbine, photovoltaic, fuel cell, and battery system using fuzzy logic. Indian Journal of Science and Technology. 2014 Feb; 7(2):113–22.
- [9] Izadbakhsh M, Rezvani A, Gandomkar M, Mirsaedi S. Dynamic analysis of PMSG wind turbine under variable wind speeds and load conditions in the grid connected mode. Indian Journal of Science and Technology. 2015 Jul; 8(14):51864.
- [10] Nabil A. Ahmed, Masafumi Miyatake, "A stand-alone hybrid generation system combining solar photovoltaic and wind turbine with simple maximum power point tracking control," IPEMC 2006, IEEE, 2006.
- [11] P. Siano, "Demand response and smart grids—A survey," Renew. Sustain. Energy Rev., vol. 30, pp. 461–478, Feb. 2014.
- [12] Guide for smart grid interoperability of energy technology and information technology operation with the electric power system (EPS), and end-use applications and loads. IEEE Standard 2030; 2011.
- [13] X. Lou, J.Wang, M. Dooner, J. Clarke, "Overview of current development in electrical energy storage technologies and the application

potential in power system operation," *Applied Energy*, vol. 137, pp. 511-536, 2015.

- [14] Kezunovic, M.; McCalley, J. D.; Overbye, T. J., "Smart Grids and Beyond: Achieving the Full Potential of Electricity Systems," *Proceedings of the IEEE* [Early access article].
- [15] Zhou Xue-song; Cui Li-qiang; Ma You-jie; "Research on Control of Micro Grid," in *Measuring Technology and Mechatronics Automation (ICMTMA), 2011 Third International Conference on*, 2011, pp. 1129-1132.