

# Smartphone controlled hexapod for search rescue and payload delivery

Harikrishnan J<sup>1\*</sup>, Dega Chandrika<sup>1</sup>, Aditi Prasad<sup>1</sup>

<sup>1</sup> Department of Electronics and Communication Engineering, Amrita School of Engineering, Amritapuri, Amrita Vishwa Vidyapeetham, India

\*Corresponding author E-mail: [harik283@gmail.com](mailto:harik283@gmail.com)

## Abstract

Rudra, the robotic hexapod has 6 independent actuators that are connected to specially designed semi-circular wheelbase for rugged motion. The robotic platform can conquer any terrain with ease and versatility. The advanced payload delivery system includes one 3 DOF arm along with a capacious block inside the body of the platform. The platform can devour any terrain including grass, gravel, mud, rocks, harsh terrain, asphalt, sand. The platform has a dynamic sensor system for real-time monitoring of its surroundings and a feedback to the end user. The entire platform is controlled by an android app.

**Keywords:** Smartphone-Controlled A Robot; Robotic Hexapod; Search and Rescue; Payload Delivery; Rugged Terrain Robot.

## 1. Introduction

Rudra a fairly developed robotic hexapod system designed for search and rescue has an advanced payload delivery system in which, in the event of a natural calamity like earthquake where payload delivery and search and rescue operations are rather hard and impossible, Rudra robotic hexapod can devour any terrain and reach its destination with ease, it can also carry a extensive amount of payload including food supplies, medicine and other tools for the search and rescue operation. The 3 DOF robotic arm anchored to the front of the platform can despatch various payloads with ease. The advanced sensor system includes a PIR human detection sensor, Ultrasonic distance measuring sensor, Global positioning system, Gas sensor and Metal detector. The smartphone app basically communicates to the robot through a Bluetooth interface, which sends the sensor feedback back to the end user and user commands back to the platform. The robot is fitted with a night vision HD IR camera for a better understanding of the surroundings. This robotic platform was inspired from animal movements such as that of a Spiny-Tailed Iguana lizard, we have tried to mimic the animal motion in our algorithm and body design in order to achieve both speed and stability.

## 2. Body design

The body design was the first challenge faced, as the body frame should house all the electronics, the battery and the powerful motors for the joints. The body should also be rugged and flexible to take on any terrain. The weight was significantly reduced when we used a low-density artificial plywood for the base frame. The shape of the frame was determined in a way that the weight will be minimum, also keeping in mind that to house the powerful high torque motors for the locomotion. The motors were fixed to the base platform using L-clamps, 6 independent motors are used for the movement of

the robot. The body mainly consists of the 3 parts, base frame, top plate, shock-absorbent base plate.

The top plate is designed to isolate the inside electronics from the outside rugged terrain, also keeping in mind for it to be easily detachable and well maintained. The base frame makes sure all the parts stay in their corresponding sectors, including the battery, electronics, and the motors. The base frame is divided into separate sectors to house different components for ease of maintenance and safety of the components from the rough and rugged terrain outside. The base plate has a shock absorbent material to absorb the impact from the ground and to protect inside housed battery and electronics.

## 3. Locomotion

As referred in the introduction the motion for the robot was inspired by the Spiny-Tailed Iguana lizard, which is the fastest lizard. Similar to its motion a pre-written algorithm inside the robot takes care of the motion. When a forward command is received from the end user a specific part of the algorithm is activated in a way that, out of the six actuators present inside the robot the first two motors to the front of the robot rotate to 270 deg from its current position, further the middle two motors take up the entire body weight of the robot and lifts itself up by turning 360 deg, finally the two motors to the back of the robots complete the gait by turning 360 deg. This algorithm is repeated for forwarding motion of the robot. The side motion is performed by turning the high torque motors 360 deg all in one go to move the robot to either side Left or Right. The robot currently does not go backward.

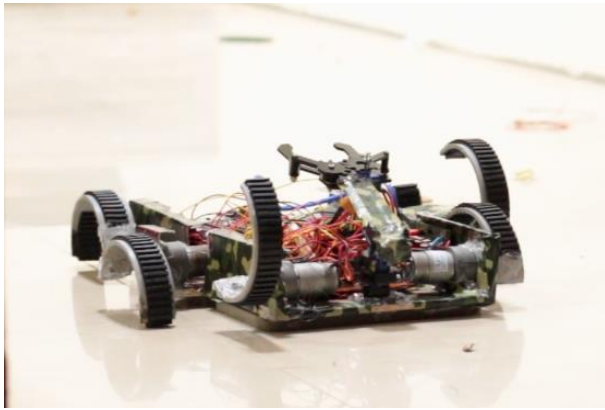

Fig. 1: Locomotion Trial of Rudra Prototype.

#### 4. Motor selection

The motor was selected in such a way that it has optimum torque and speed. Johnson geared DC motor has exclusive high torque, best suitable for highly developing capable robots or robotic platform, various automation purposes. The gear of this motor is built to withstand the high torque. The motor specifications include 100 RPM 12V DC Motor With Gear Box, 18000 RPM base motor, Shaft: 6mm, Gearbox diameter: 37 mm, Gear: metal spur gear assembly, Load current = up to 5 A(Max). Six similar motors were used for the entire build. The high torque motors can accommodate a capacious payload inside the robot with ease.

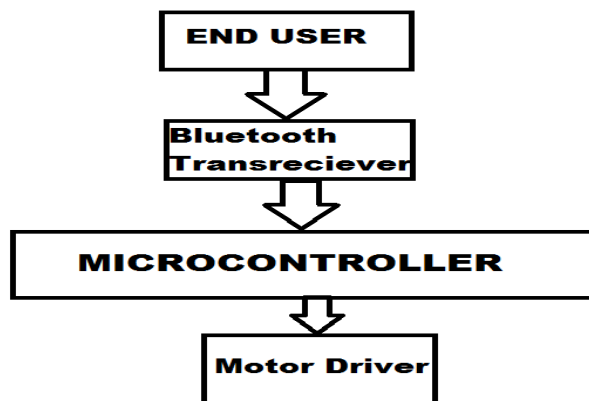

Fig. 2: The Flow of Control Motor Working.

#### 5. Power supply

Lithium polymer batteries work on the principle of intercalation and de-intercalation of lithium ions from a positive electrode material and a negative electrode material, with the liquid electrolyte inside the cell provides a conductive medium. In order to prevent the electrodes from being in direct contact with each other, a microporous separator is in between the layers which allow only the ions and not the electrode particles to migrate from one side to the other.

Product Type: Lithium polymer battery pack, Model no: Orange 2200mAh 40C 3S1P, capacity:2200mAh, weight: 175.0gram, voltage: 11.1V, dimensions: 25x34x105mm, max continuous discharge: 40C(88.0A), balance plug: JST-XH max burst discharge: 80C(176.0A), discharge plug: XT-60, charge rate: 1-3C recommended, 5C Max.

#### 6. Sensor system

Ultrasonic obstacle sensor sends eight 40kHz waves and waits for its return, after reflection if all eight waves return with same high levels it calculates the test distance as  $\text{Test distance} = (\text{high-level time} \times \text{velocity of sound } (340\text{M/S}) / 2$ . Ultrasonic distance sensor is a Noncontact sensor with an accuracy of 3mm. Its range differs

from 2-3 meters. This module detects an obstacle in front of the robot within a 4-meter range and reports it back to the user.

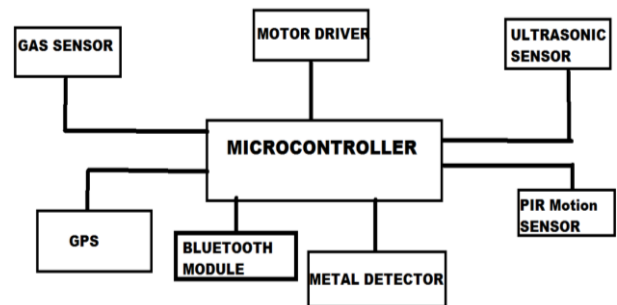

Fig. 3: Block Diagram of the Main Electronic System.

PIR sensor or passive infrared sensor is used to detect motion. Everything emits a certain level of infrared radiation, the sensor contains two halves of a pyroelectric or IR sensor. The output swings between high or low depending on the input to these halves. Using the micro-controller we take input from the PIR sensor as either HIGH or LOW to detect the presence of somebody on the premises. PIR sensor is a low cost, low power sensor so it is the best choice for the robot.

GPS Global Positioning System is a method by which the location is identified by using 24 dedicated satellites to pinpoint the location of a certain object. In this platform we use a GPS module to calculate the current position of the robot and the GPS data in Longitudes and latitudes is relayed by to the end user via a Bluetooth link in real-time for better guidance of the robot. This module has superior sensitivity the antenna connects to 66 satellites while providing a fast time to first fix service.

#### 7. Control of motors

Six independent motor drivers are used to control the motors, the motor drivers also act as a voltage regulator to supply power to the development board. Each of the motor drivers is connected to a pulse width modulation enabled pin in the controller. The actual position of the motor is fixed by changing the delay time in the algorithm. The motor rotates at 100 rpm without load and after it is attached to the body and when it is carrying a load it was rotating at about 40 rpm.

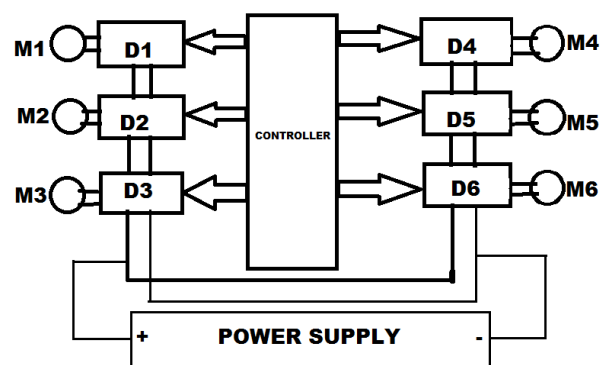

Fig. 4: Block Diagram of Motor Driver Integration.

#### 8. Smartphone link

All the sensor data is transmitted back to the end user via a Bluetooth link. A transceiver Bluetooth module inside the robot broadcasts the data from the robot over to the receiver in a smartphone. The smartphone pairs with the Bluetooth module, a master-slave connection is established and further the instructions from the end user regarding the locomotion of the robot is transmitted to the robot through a serial communication link. Simultaneously a feedback of sensor data is reported back from the robot.

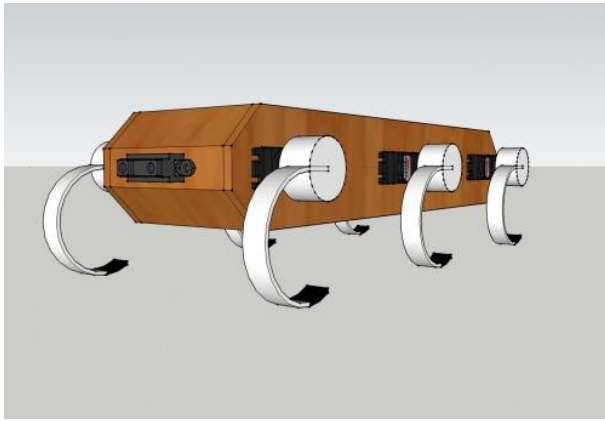

Fig. 5: Semi-Circular Wheel Modules and Base Build.

## 9. Micro-controller and IDE

Development board used is an open-source development board called Arduino Mega 2560 in which the main micro-controller is ATMEGA 2560 of Atmel Corporation. The development board contains 54 pins for input and output requirements. It also has 16 Pulse width Modulation enabled pins. It communicates through a computer through a dedicated USB header. The development board has a 16 MHz clock crystal. The Integrated Development Environment or IDE used was Arduino 1.8.5. It is based on Processing Language. The program supports multi-platform including Windows, Linux, Mac OS X. The program interfaces to the development board through a USB link. It uses Serial communication to broadcast to and from the board.

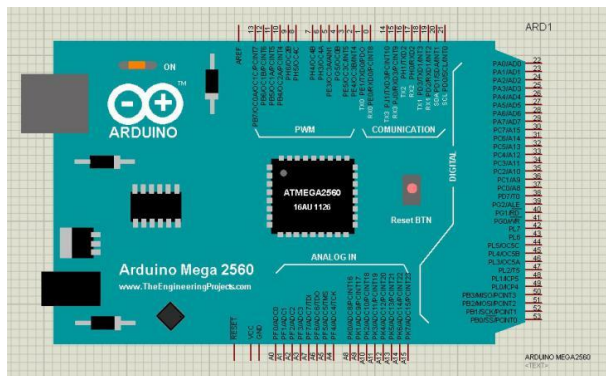

Fig. 6: Arduino Mega 2560.

## 10. Challenges faced

In the order of building the robot the first challenge faced was that of choosing a rugged material for body design, although we chose a low-density artificial plywood it is not rugged enough. The material should be lightweight and strong also flexible enough to take the impact. The leg modules were the next challenge as the module should be durable, grippy and flexible enough to take all the impact. Different kinds of modules can be used for different terrain and surround settings. The motor selection was made in such a way that it can carry heavy loads with ease, so a high torque 100rpm motor was used. A decoder enabled motor would be perfect for the build as it gives a feedback on the current position. The power supply was chosen in a way that it dispatches adequate amount of power as fast as the possible need for the six motors present inside the robot. The overall shielding of the robot should be made rugged to take impact from any side of the robot.

## 11. Application in real life

Robot-assisted search and rescue. Inspection and structural assessment of critical infrastructure, Nuclear site monitoring, decommissioning, and hazardous waste cleanup. Search and rescue, Floods, landslides, and earthquakes, It can access any terrain and carry a payload. Deliver medicines tools and other packages to disaster struck places or rugged terrain, inaccessible to normal wheeled robots.

## 12. Conclusion

The future plan for the robot is that to make it completely autonomous, to build an intelligent robot capable of detecting a human in danger in a rugged or rough terrain to devour the land and to reach and assist the human in need. To increase the payload carrying capacity even more. At a future stage, even this can be used to recover a human from a disaster-hit area completely autonomously. More sensory systems including a point cloud mapping system can be implemented for better interaction with the surroundings. Machine learning and computer vision can be used to identify humans in need and for effective locomotion. An intelligent algorithm self-tuned by the robot for different terrain structures can make the processing much simpler.

## Acknowledgement

We would thank god almighty for his grace, Amrita University, Amritapuri Campus, Humanitarian Technology Labs, Ammachi Labs for all their support and guidance. We also thank all our well wishers for their blessings.

## References

- [1] N. Neville, I. Sharf "A bipedal running robot with one actuator per leg" *International Conference on Robotics and Automation*, 2006.
- [2] Boston Dynamics "RHex Devours Rough Terrain." content on the web.
- [3] D. E. Koditschek, U. Saranlı "RHex: A Simple and Highly Mobile Hexapod Robot," *The International Journal of Robotics Research*, vol.20, no. 7, 2001.
- [4] E. Moore, "Leg design and stair climbing control for the RHex robotic hexapod" McGill University, 2002.
- [5] J. D. Weingarten, G. A. D. Lopes, M. Buehler, R. E. Groff, and D. E. Koditschek, "Automated gait adaptation for legged robots," in *Proceedings of the IEEE International Conference on Robotics and Automation*, vol. 3, 2004.
- [6] Megalingam, R.K., Vivek, G.V., Bandyopadhyay, S., Rahi, M.J. "Robotic arm design, development and control for agriculture applications" 2017 4th International Conference on Advanced Computing and Communication Systems, ICACCS 2017 8014623.
- [7] Megalingam, R.K., Sreekanth, S., Govardhan, A., Teja, C.R., Raj, A., "Wireless gesture controlled wheelchair" 2017 4th International Conference on Advanced Computing and Communication Systems, ICACCS 2017 8014621.
- [8] Varghese, J.M., Megalingam, R.K., "Study and analysis of embedded system based indoor navigation on multiple platforms", International Conference on Communication and Signal Processing, ICCSP 2016 7754343, pp. 1203-1207.
- [9] Megalingam, R.K., Prem, A., Nair, A.H., Pillai, A.J., Nair, B.S., "Staircase cleaning robot: Design considerations and a case study", International Conference on Communication and Signal Processing, ICCSP 2016 7754247, pp. 760-764.
- [10] Megalingam, R.K., Vignesh, N., Sivanantham, V., Sharathkumar, M.S.
- [11] "Low-cost robotic arm design for pruning and fruit harvesting in developing nations", Proceedings of the 10th International Conference on Intelligent Systems and Control, ISCO 2016 7727016.