



# A Fuzzy adaptive hysteresis band controller for three phase four wire UPQC

S.Shamshul Haq<sup>1\*</sup>, D. Lenine<sup>2</sup>, S. V. N. L. Lalitha<sup>3</sup>

<sup>1</sup>Research Scholar, <sup>3</sup>Professor, EEE Dept, K L Education Foundation, Guntur, India.

<sup>2</sup>Professor, EEE Dept, RGM CET, Nandyal, India

\*Corresponding Author Email: shaik.shamshul@gmail.com

## Abstract

Unified Power Quality Compensator (UPQC) is used to protect the sensitive loads in the distribution system from voltage and current disturbances. The compensation capability of UPQC depends on the control strategies used for shunt and series converters. Conventional adaptive hysteresis controller pulse width modulation technique had failed to track exactly during transient conditions and disturbances at load and source side. In paper fuzzy adaptive hysteresis controller is proposed for three phase four wire UPQC for compensating voltage sag/swell, current harmonics, voltage harmonics and neutral current compensation. Fuzzy adaptive hysteresis controller can effectively compensate the power quality problems during the transient conditions. A comparative simulation analysis of proposed and conventional methods are presented in this paper using MATLAB/SIMULINK tool.

**Keywords-**UPQC, Sag/Swell, Harmonics, Hysteresis Controller, Fuzzy logic.

## 1. Introduction

Now a days electrical loads has become more sophisticated and very sensitive to supply voltage disturbances. The poor quality of electric energy has become savior problem to industrialists in term of loss production and damage of materials. Due to increase in nonlinear loads like speed control drives, power electronic devices, fluorescent lightning and computers etc. These loads cause power quality problems by producing harmonics, distorted voltage signal. Faults in the distribution network produces power quality problems like voltage sag/swell, unbalanced voltage, interrupts, phase angle jump etc. The present era electrical loads like computer,

microprocessor, and devices based on hospitals and home applications are very sensitive to such PQ problems. The modern distribution system should provide good power quality by compensating the power quality problems.

A complete solution for improving power quality in the network and protecting sensitive loads can be done by combination of the series-shunt active power filter called unified power quality conditioner [1-2]. Recently UPQC has gained much more attention due to its compensation capability of both voltage and current quality problems. It can compensate problems like voltage sag/swell, voltage harmonics, current harmonics, neutral current, unbalanced current, reactive power compensation etc. The block diagram of UPQC is as represented in Fig.1.

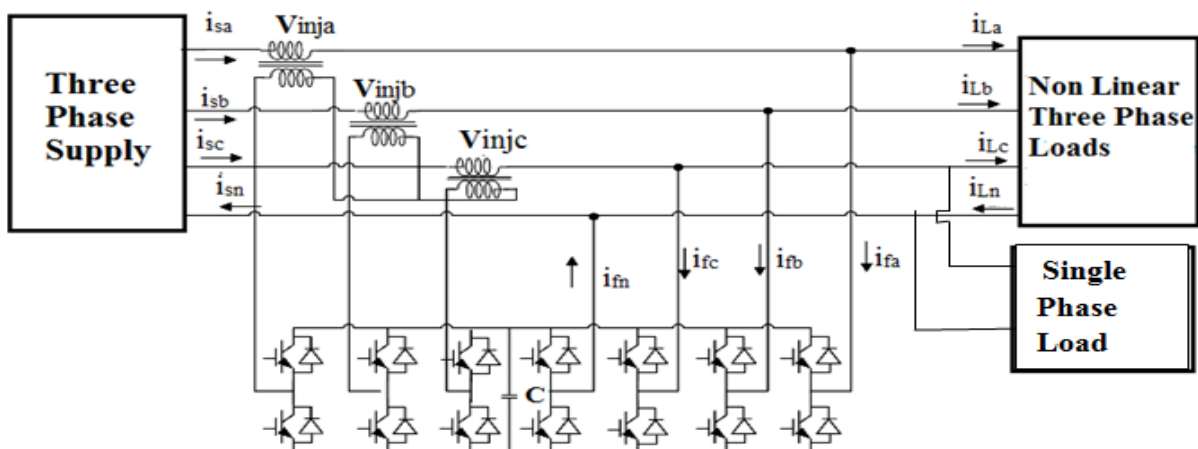


Fig. 1: Block diagram of UPQC

In order to meet these demand new control strategies has to be developed for fast and accurate extraction of reference signals. It consists of two major control strategies, one is to generate the reference signal and the other is to produce the switching signals. Instantaneously active and reactive power theory also know as PQ theory and synchronous reference frame theory are mostly used algorithm to generate reference signals for both shunt and series active power filters. Synchronous reference frame theory is mostly preferred control algorithm because of better compensation capability during transient conditions [3]

Different current and voltage control strategies are proposed in [4-6], namely PI control, Average current mode control(ACMC), sliding mode control(SMC), and hysteresis control. Hysteresis control is the mostly popularly used controller, because of its easy and simplicity in implementation. Hysteresis Band Controller (HBC) with fixed hysteresis band has drawbacks, like uneven switching frequency, high ripple current, stress on switching devices. To overcome above said drawbacks Adaptive Hysteresis Band Controller(AHBC) is proposed in [7]. Adaptive hysteresis controller maintains the switching frequency constant by varying the hysteresis band. Adaptive hysteresis controller fails to provide excellent performance during dynamic as well as uncertainty of supply voltage and load. To eliminate these drawbacks Fuzzy Adaptive Hysteresis Controller(FAHBC) is proposed in this work. In this work compensation of voltage sag/swell, voltage harmonics, current harmonics and neutral current compensation is done based on fuzzy hysteresis controller. And the results are compared with convention adaptive hysteresis controller and hysteresis band controller. Generally, In three phase four wire UPQC, the mitigation of neutral current can be obtained with different topologies of shunt

APF. A shunt APF with three leg VSI with split capacitor faces difficulty in maintaining balanced voltage across the two capacitors. Three single phase VSI is not compatible because more number of switching devices, nearly 24 semiconductor devices are used. A four leg VSI is most compatible topology, easy to design and it requires less devices as compared to three single phase VSI.

### 2. Control Algorithm For Shunt Converter

Fig.2 shows the control structure of UPQC, it is based on SRF theory for generation of reference current and reference voltage signals. For shunt active power filter load current, source voltage and DC-link voltages are taken as feedback signals. By using Parks transformation load currents are transformed to dqo frame using equation (1). A phase locked loop is used to synchronize dqo signals with the source voltages.

$$\begin{bmatrix} i_{Ld} \\ i_{Lq} \\ i_{Lo} \end{bmatrix} = \frac{2}{3} \begin{bmatrix} \cos \theta & \cos(\theta - \frac{2\pi}{3}) & \cos(\theta + \frac{2\pi}{3}) \\ -\sin \theta & -\sin(\theta - \frac{2\pi}{3}) & -\sin(\theta + \frac{2\pi}{3}) \\ \frac{1}{2} & \frac{1}{2} & \frac{1}{2} \end{bmatrix} \begin{bmatrix} i_{La} \\ i_{Lb} \\ i_{Lc} \end{bmatrix} \quad (1)$$

The direct-axis and quadratic -axis components consists of fundamental and harmonic components. The fundamental components are extracted by using LPF.

$$i_{Ld} = \bar{i}_{Ld} + \tilde{i}_{Ld} \quad (2)$$

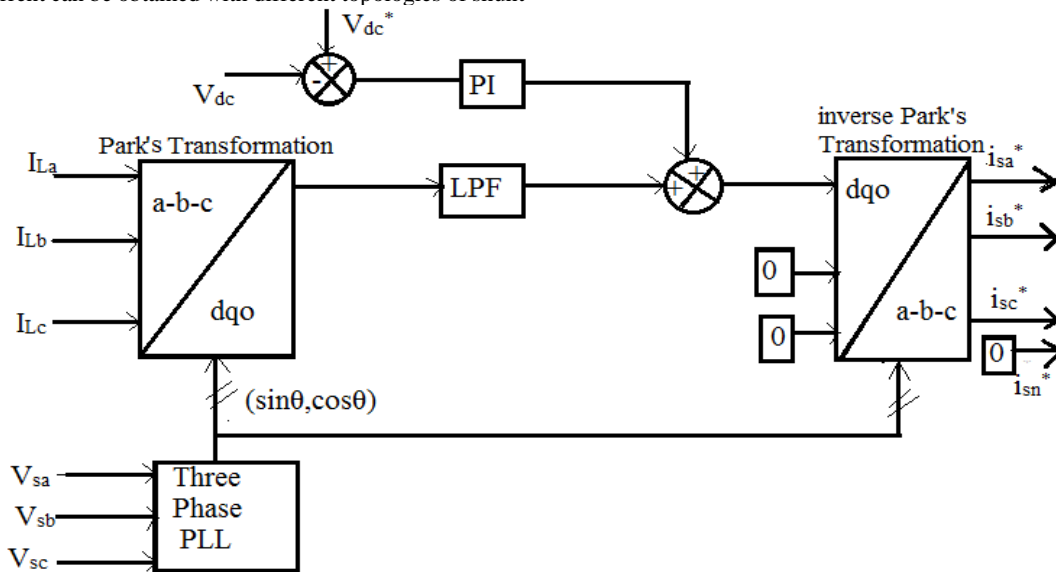


Fig. 2: Control algorithm of Shunt Converter

A small amount of active power is drawn by shunt APF to maintain the DC bus voltage and the losses( $i_{loss}$ ). The difference between reference DC voltage and sensed ( $V_{dc}$ ) DC voltage is the error signal. The error signal is given as an input for PI controller and the output of PI controller is considered as the current ( $i_{loss}$ ) signal. The summation of fundamental DC-current component and current( $i_{loss}$ ) gives the reference direct axis supply current.

$$i_d^* = i_{ddc} + i_{Loss} \quad (3)$$

By applying inverse parks transformation the reference current signals are obtained.

$$\begin{bmatrix} i_{sa}^* \\ i_{sb}^* \\ i_{sc}^* \end{bmatrix} = \frac{2}{3} \begin{bmatrix} \cos \theta & -\sin \theta & 1 \\ \cos(\theta - \frac{2\pi}{3}) & -\sin(\theta - \frac{2\pi}{3}) & 1 \\ \cos(\theta + \frac{2\pi}{3}) & -\sin(\theta + \frac{2\pi}{3}) & 1 \end{bmatrix} \begin{bmatrix} i_d^* \\ i_q^* \\ 0 \end{bmatrix} \quad (4)$$

The neutral current in the fourth wire is sensed and compared with reference value, which is set to zero. The error signal generated, is given as an input to hysteresis current controller to generate the triggering pulse for the two switches in the fourth leg of shunt APF.

### 3. Control Algorithm for Series Converter

Three phase reference voltages signals for series APF are generated using SRF theory, the control algorithm is as shown in Fig.3. A PLL is used to synchronize the distorted supply voltage[8] and it generates two quadrature unit vectors( $\sin\omega t$ ,  $\cos\omega t$ ). Three phase voltage will have only 'd' component if it is distortion free and of constant magnitude. The other 'q' and '0' components will be zero. Hence reference voltage signals are obtained with the help of PLL and desired peak voltage (415v) value by applying inverse parks transformation using equation.(5).

$$\begin{bmatrix} V_{La}^* \\ V_{Lb}^* \\ V_{Lc}^* \end{bmatrix} = \frac{2}{3} \begin{bmatrix} \cos \theta & -\sin \theta & 1 \\ \cos(\theta - \frac{2\pi}{3}) & -\sin(\theta - \frac{2\pi}{3}) & 1 \\ \cos(\theta + \frac{2\pi}{3}) & -\sin(\theta + \frac{2\pi}{3}) & 1 \end{bmatrix} \begin{bmatrix} V_d \\ 0 \\ 0 \end{bmatrix} \quad (5)$$

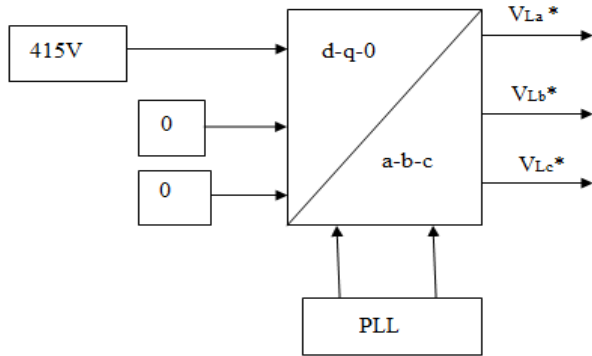


Fig. 3: Control algorithm of Series Converter

### 4. Fuzzy Hysteresis Band Current Controller

Hysteresis band current control technique is mostly used for all current controlled voltage source inverters due to its simplicity in implementation and very quick response. It exhibits some drawbacks like uneven switching frequency which causes stress on the switches and increases switching losses. To overcome the drawbacks of fixed hysteresis band controller adaptive hysteresis controller is used. Adaptive hysteresis controller changes the hysteresis band width as a function of reference current to maintain constant switching frequency. The hysteresis bandwidth is given as[9].

$$HB = \frac{1}{V_{dc} 2f_c L_{sha}} \left[ \frac{V_{dc}}{4} - (V_{sa} + i_{ref} R_{sha})^2 \right] \quad (6)$$

The hysteresis band calculated from above equation will be identical with phase difference. Where  $V_{sa}$ ,  $i_{ref}$ ,  $V_{dc}$  is source voltage, reference current, dc-link voltage.

A precise knowledge is required for current control with adaptive hysteresis current control. To improve the performance of adaptive hysteresis current controller fuzzy logic controller is implemented in this paper. The input variables for fuzzy logic controller are source voltage and the slope of reference current are taken and HB is the output variable. Fig.4 shows the block diagram of fuzzy adaptive hysteresis controller. It is noted from the equation that the hysteresis band width of current controller is a function of reference current and source voltage, so change in the reference current and source voltage changes the HB.

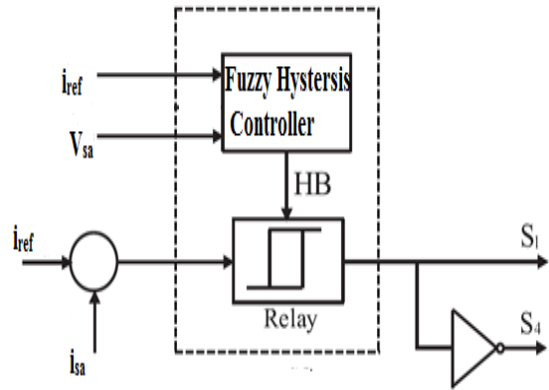


Fig. 4: Fuzzy Adaptive Hysteresis Current Controller

Five input and output linguistic variables are used in this case. Triangular membership functions are used as shown in Fig.5. The fuzzy rules are as shown in Table 1. By using fuzzy logic controller the switching frequency is kept constant and the current error is reduced for better stability to parameter variations.

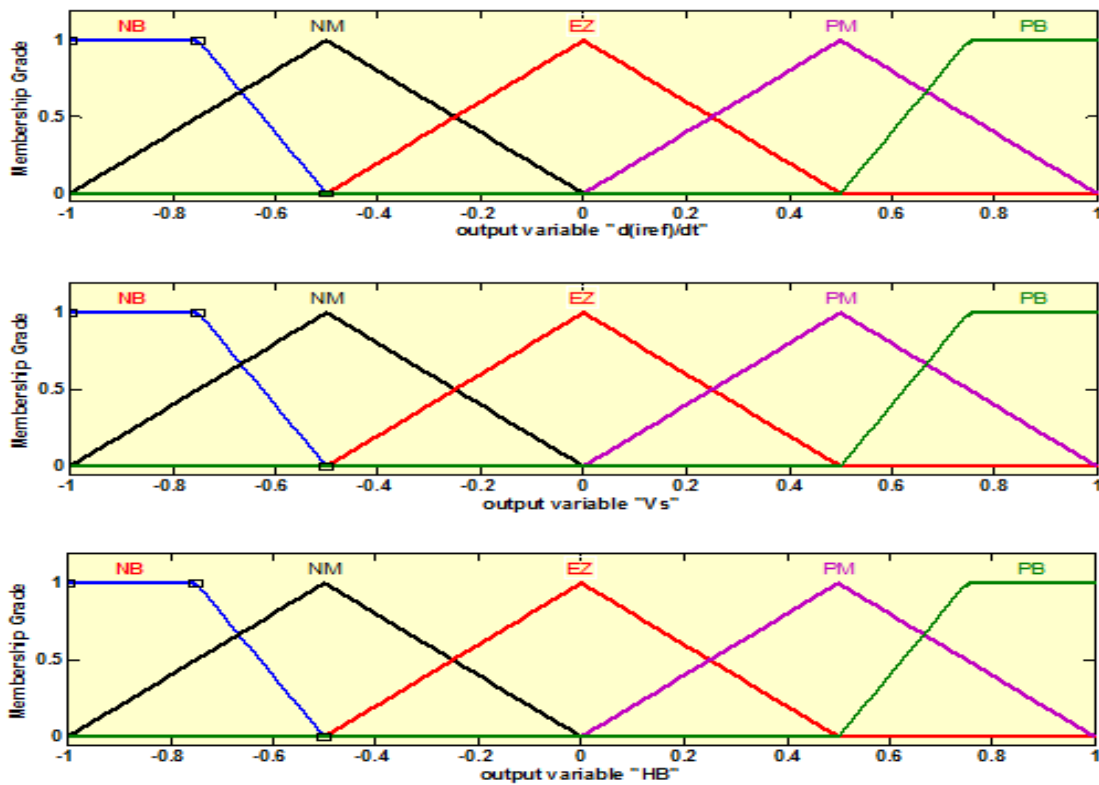


Fig. 5: Fuzzy Membership Functions of Input  $V_s$ ,  $\frac{d}{dt}(i_{ref})$  and Output HB

**Table 1.** Control Rule Table

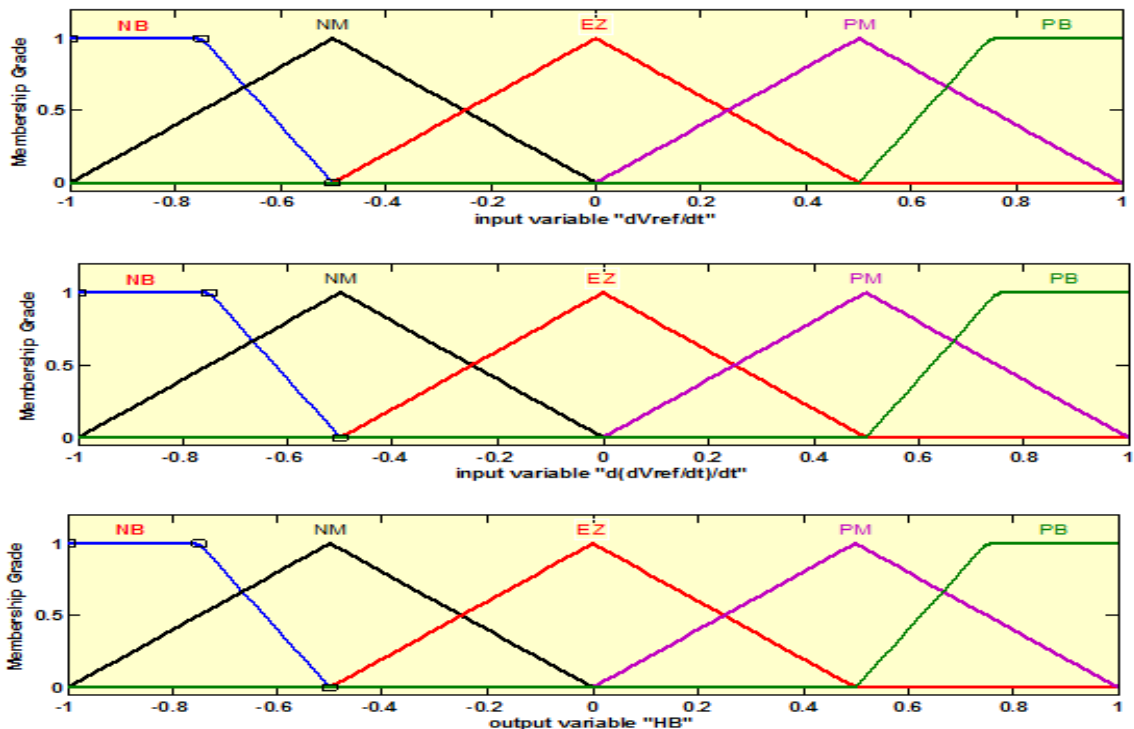
e	NL	NM	NS	EZ	PS	PM	PL
ce							
NL	NL	NL	NL	NL	NM	NS	EZ
NM	NL	NL	NL	NM	NS	EZ	PS
NS	NL	NL	NM	NS	EZ	PS	PM
EZ	NL	NM	NS	EZ	PS	PM	PL
PS	NM	EZ	PS	PM	PL	PL	PL
PM	NS	EZ	PS	PM	PL	PL	PL
PL	EZ	PS	PM	PL	PL	PL	PL

The adaptive hysteresis band controller for series active power filter is given in equation [10].

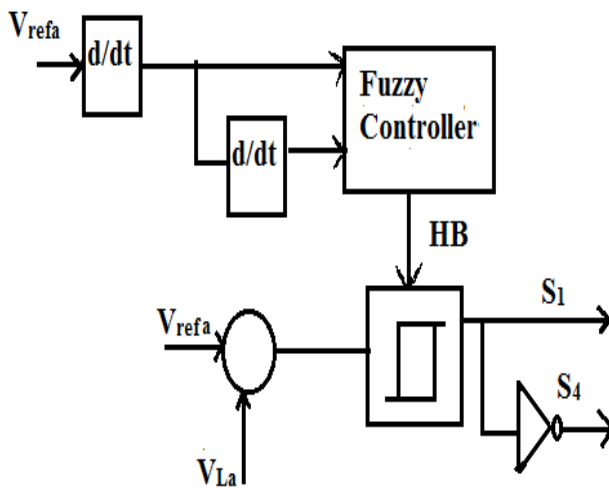
$$HB = \frac{R_{sw}}{4f_{sw}V_{dc}L_{ts}} \{V_{dc}^2 - V_{mref}^2 \sin^2(wt)\} \tag{7}$$

The above equation varies the hysteresis band width so as to keep the switching frequency constant. To improve the performance of a fuzzy logic controller is used to generate the hysteresis bandwidth. To implement the fuzzy logic controller for adaptive hysteresis band, reference voltage slope  $d(V_{ref})/dt$  and its derivative is considered as input variables and HB as an output variable. The membership functions of input and output variables are as shown in Fig.6 and the output rules are same as that of table.1. The block diagram representation of FAHBC is as shown in Fig.7.

### 5. Fuzzy Adaptive Hysteresis Voltage Controller



**Fig. 6:** Fuzzy Membership Functions of Input  $\frac{d}{dt}V_s$ ,  $\frac{d}{dt}(\frac{d}{dt}V_s)$  and Output HB



**Fig. 7:** Fuzzy Adaptive Hysteresis Voltage Controllers

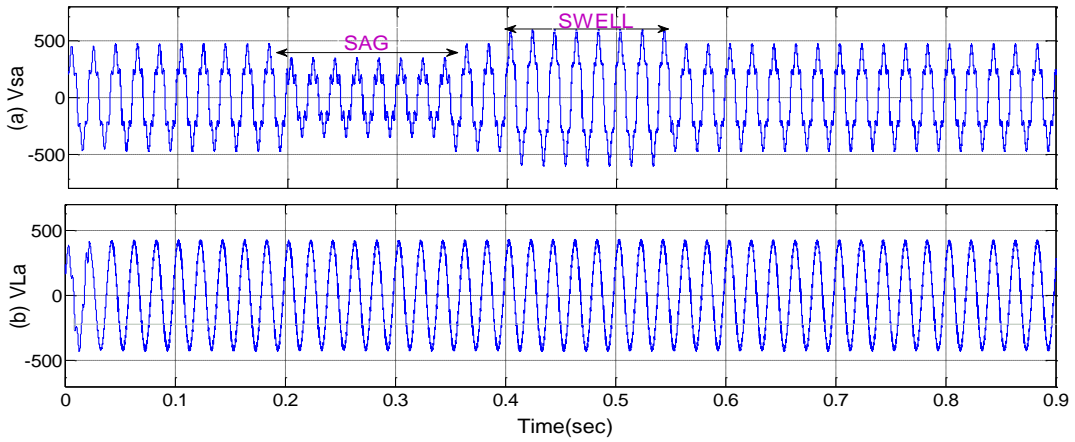
### 6. Simulation Results and Discussion

To analyze the performances of proposed fuzzy hysteresis controller for both shunt and series converter are evaluated using MATLAB/SIMULINK tool. The parameters used for the design of simulink models are as shown in table.1. To validate the proposed method an expansive simulation study with comparison of the conventional method is accomplished in this work. Further to analyze compensation capabilities the simulation models are tested under different conditions such as transient load ,single phase load, voltage sag, swell, source current and load voltage harmonics and source neutral current compensation. The tracking performances of the reference current and actual compensating currents of both proposed and conventional method, generated hysteresis band and generated switching pulses waveforms simulation results are also presented. In this work, distorted source voltage with 5<sup>th</sup> and 7<sup>th</sup> harmonics is considered. Two diode bridge rectifiers with RL loads is considered for steady-state and transient condition as nonlinear loads. A single phase diode bridge rectifier with RL load is taken to produce unbalanced load.

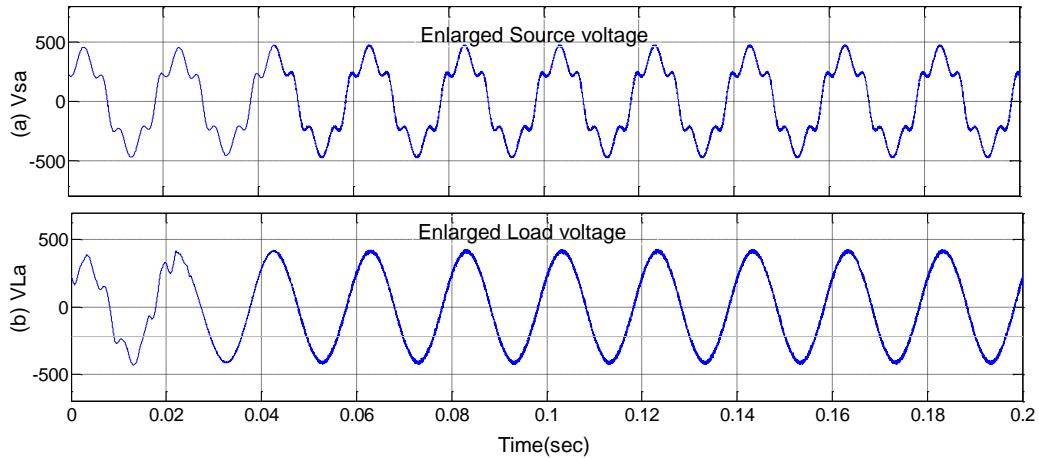
**A. With Adaptive Hysteresis Band Controller**

Sag and swell compensation with adaptive hysteresis controller are shown in Fig.8. A sag of 30% of the rated source voltage is created at time  $t=0.2\text{sec}$  to  $t=0.35\text{sec}$  and a swell of 30% of the rated source

voltage at time  $t=0.4\text{sec}$  to  $t=0.55\text{sec}$  to the source voltage. Fig.8(b) shows the load voltage with compensation of sag and swell.



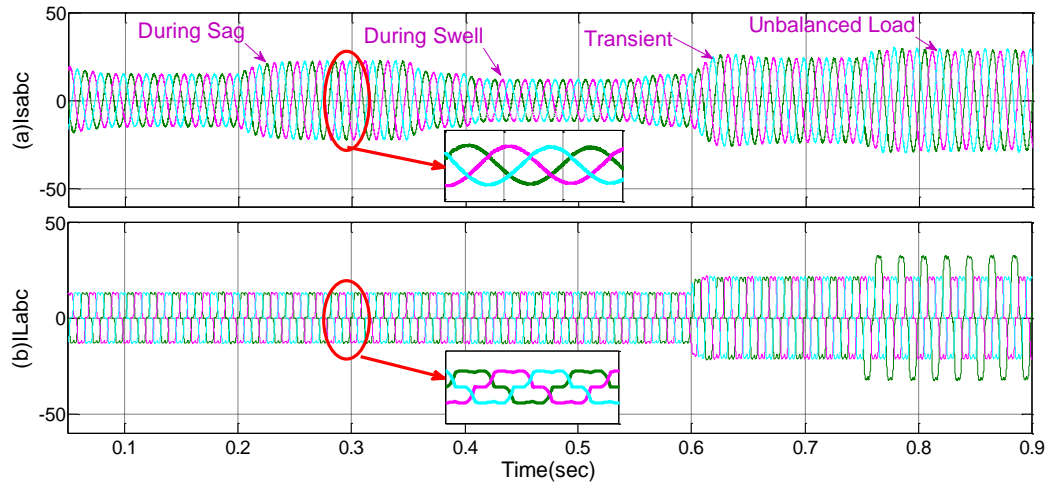
**Fig. 8:** Measured Waveforms with AHBC a) Sources Voltage b) Load Voltage.



**Fig. 9:** Enlarged Waveforms of a) Sources Voltage b) Load Voltage.

Fig.(9) shows the enlarged source voltage and load voltage waveform. Fig. 9(a) shows the distorted source voltage and Fig .9(b) shows the compensated sinusoidal load voltage at the load.

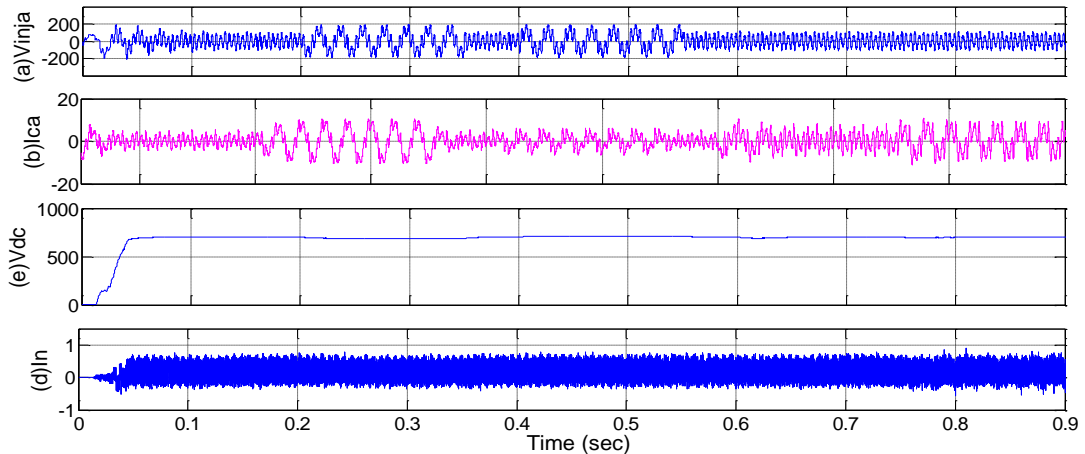
Fig.10 shows the source current and load current waveforms. The current harmonics injected by the load are compensated by the shunt converter at point of common coupling and the source current harmonics are maintained below %5 as per IEEE standard.



**Fig. 10:** Measured Waveforms with AHBC a) Source Current b) Load Current.

During sag and swell, current drawn from the source will increase and decrease to maintain constant power in the system. At time  $t=0.6\text{sec}$  load is increased to analyze the transient response of the

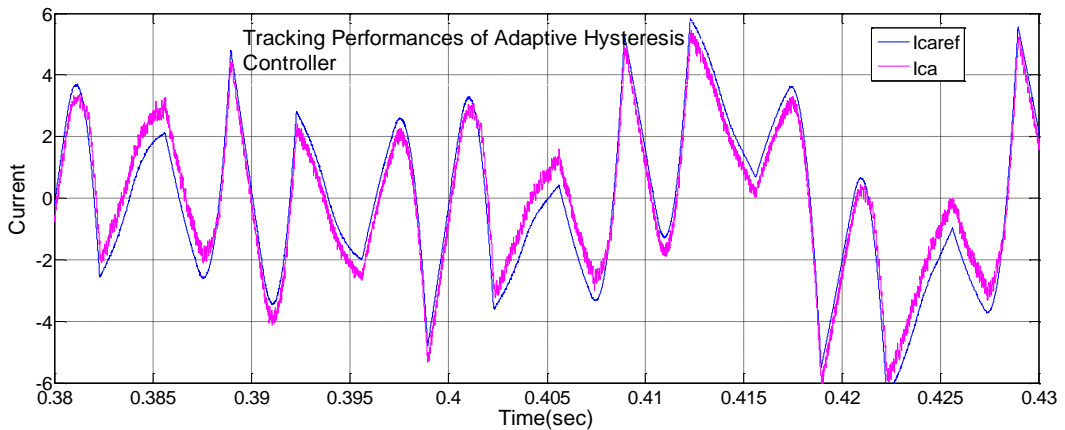
UPQC. At time  $t=0.75\text{sec}$  single phase load is applied so that unbalanced current starts flowing in the neutral wire.



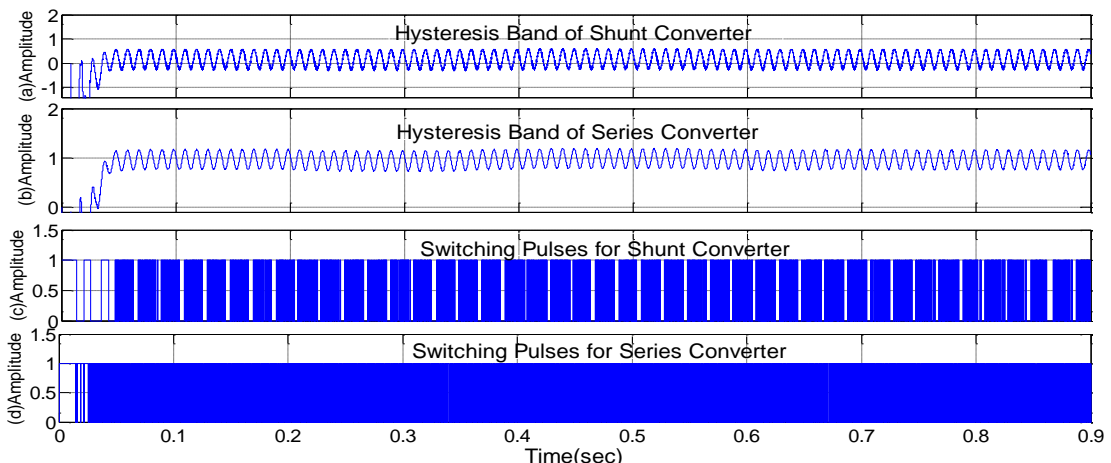
**Fig. 11:** Measured Waveforms With AHBC a)Injected Voltage of Series Inverter b)Compensating Current of Shunt Converter c)DC link Voltage d) Neutral Current.

The waveform of voltage injected by the series converter is shown in Fig.11(a). The compensating current produced by shunt converter to compensate current harmonics is as shown in Fig.11(b). The voltage across the DC link is shown in Fig.11(c). It is maintained nearly constant at 700V. The Fig.11(d) shows the current in the neutral wire. The fourth leg of shunt converter is responsible to compensate the current in the neutral wire during unbalanced load.

Fig.(12) shows the tracking performances of compensating current with AHCC. From the Fig.(12) it can be seen that during swell the compensating current slightly deviates from the reference compensating current. To maintain constant switching frequency, hysteresis band is varied. The variation of hysteresis band with adaptive hysteresis band is as shown in Fig.13(a) and Fig.13(b). Fig.13(c) and Fig.13(d) shows the generated switching pulses for shunt and series converter.



**Fig. 12:** Compensating Reference Current and actual Compensating Current with AHBC.

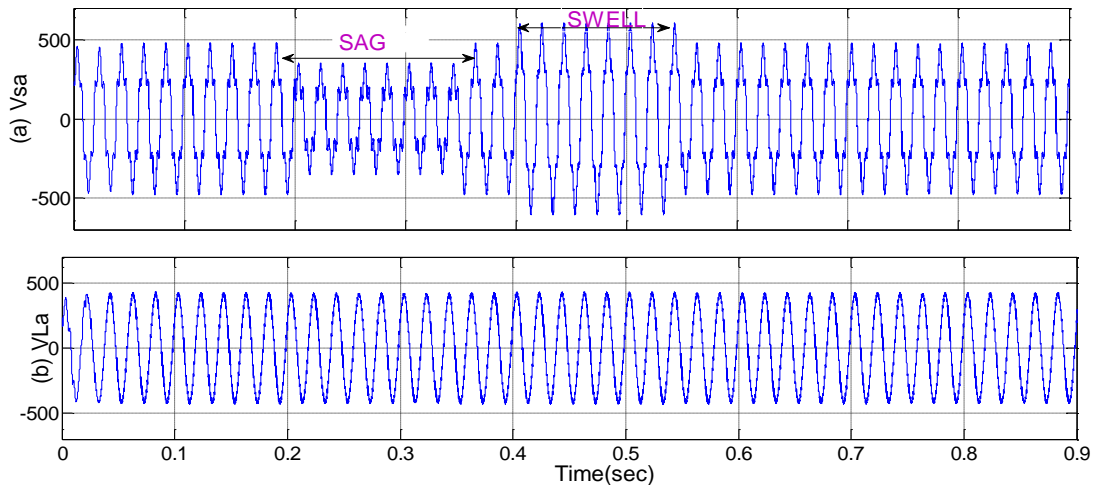


**Fig. 13:** Waveform of hysteresis band and Switching Pulses of Shunt and Series Inverter with AHBC.

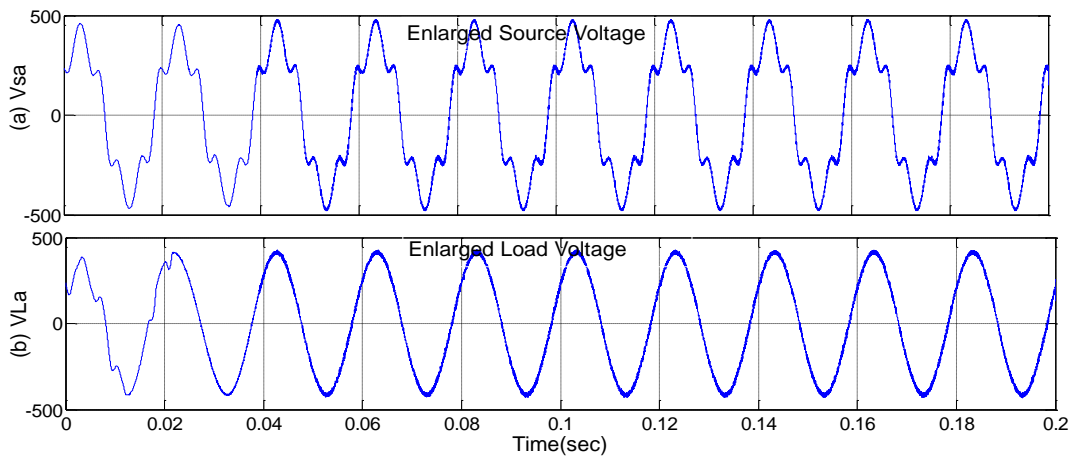
**B. With Fuzzy Adaptive Hysteresis Band Controller.**

Adaptive hysteresis has poor harmonic compensation during swell, The %THD of source current during swell is more than %5 which is higher than the IEEE standard value. In order to improve the power quality fuzzy adaptive hysteresis controller is design in this

paper. Fig.(14) shows the source voltage and load voltage waveform for compensation of sag and swell. The voltage harmonics at source voltage are compensated at the load voltage as shown in Fig.(15 ).

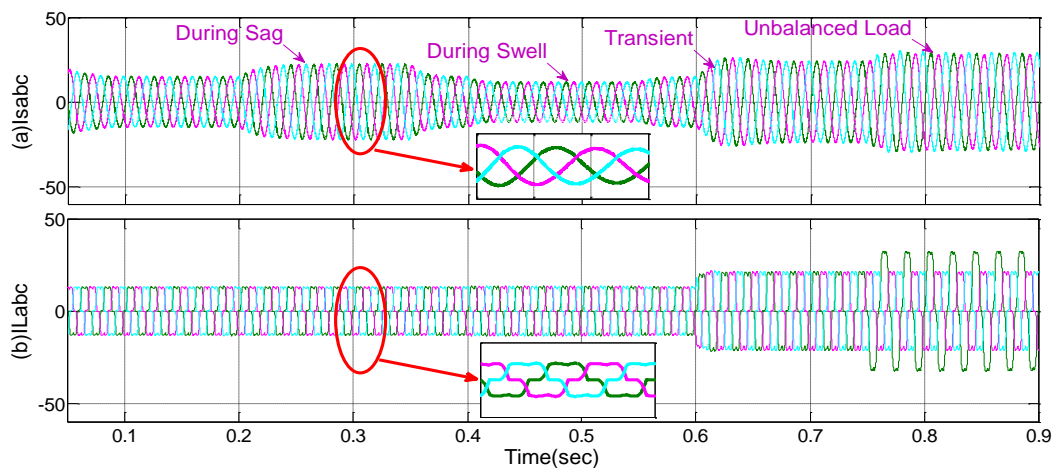


**Fig. 14:** With FAHBC a) Source Voltage Waveform b) Load Voltage Waveform

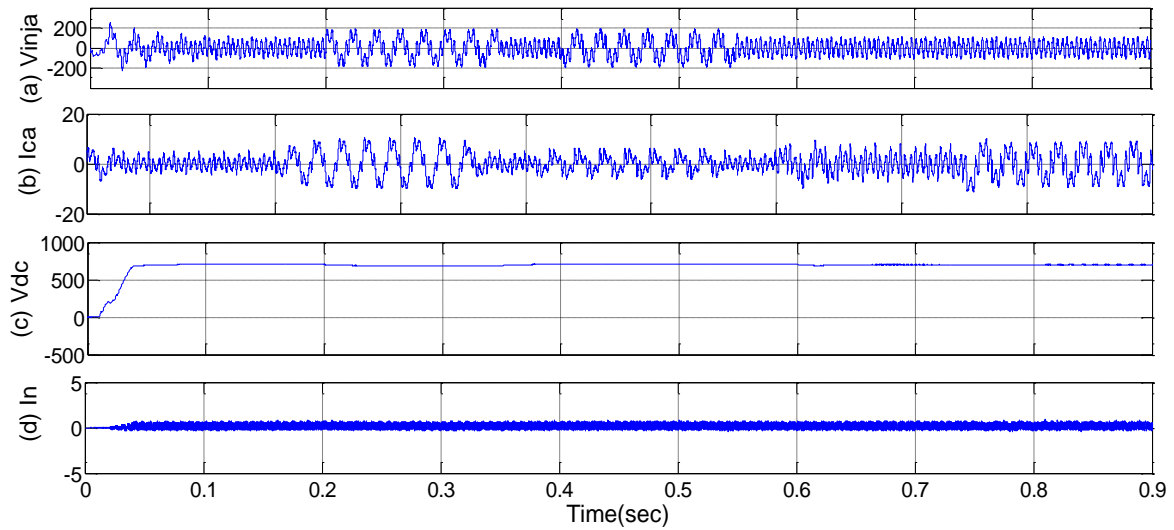


**Fig. 15:** a) Distorted Source Voltage b) Compensated Load Voltage.

Source current harmonics compensation waveform is as shown in Fig.(16). Fig.16(a) is load voltage waveform. During unbalanced load at t= 0.75sec, balancing of source current is achieved.



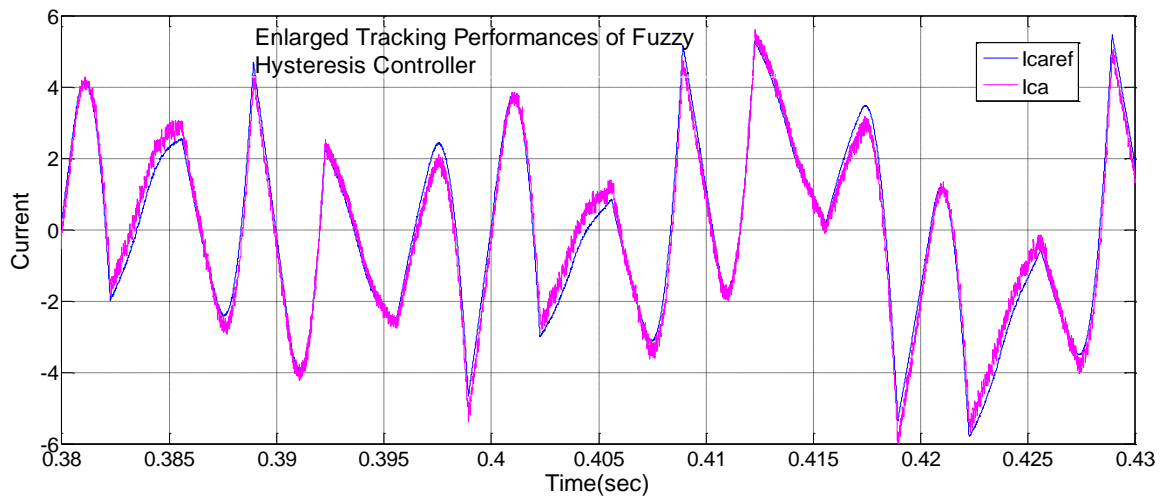
**Fig. 16:** With FAHBC Waveforms of a)Source Current b)Load Current



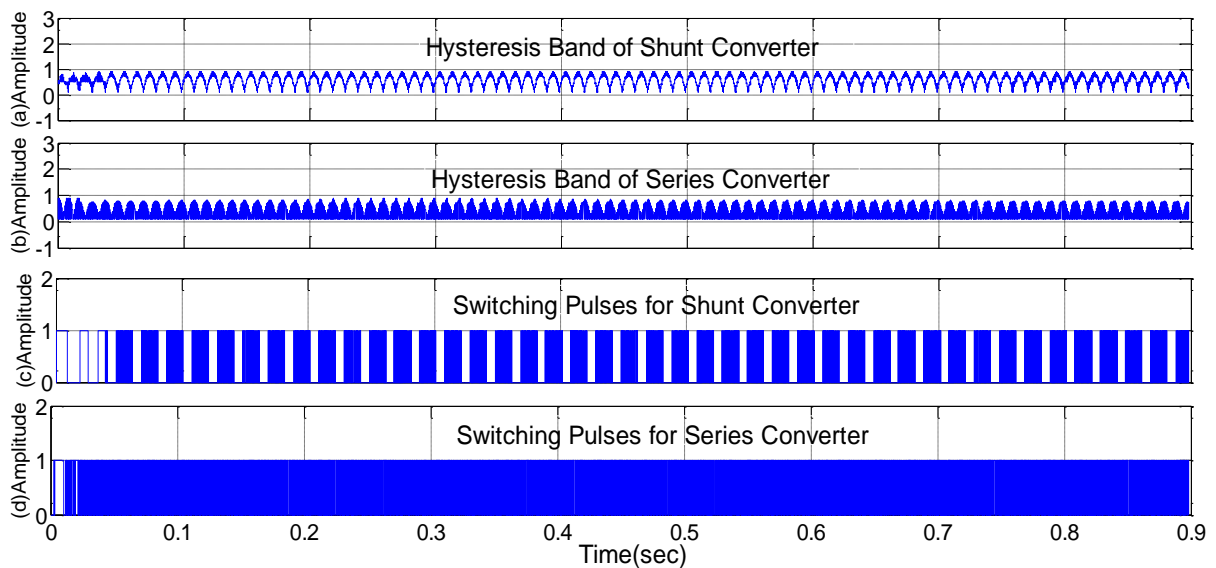
**Fig. 17:** Measured Waveforms With FAHBC a)Injected Voltage of Series Inverter b)Compensating Current of Shunt Converter c)DC link Voltage d) Neutral Current

Fig.(17) shows the voltage injected, compensating current, DC link voltage and neutral current waveforms using fuzzy adaptive hysteresis controller. The tracking performance of compensating current with fuzzy adaptive hysteresis controller is shown in

Fig.(17). From the figure it can be seen that the tracking performances of fuzzy adaptive hysteresis controller is better than adaptive hysteresis controller.



**Fig. 18:** Compensating Reference Current and actual Compensating Current with FAHBC.



**Fig. 19:** Waveform of Fuzzy Adaptive hysteresis band and Switching Pulses of Shunt and Series Inverter.

The output of fuzzy controller is hysteresis band which is as shown in Fig.(19). A variable hysteresis band is produced so as to keep the switching frequency of the inverters constant.

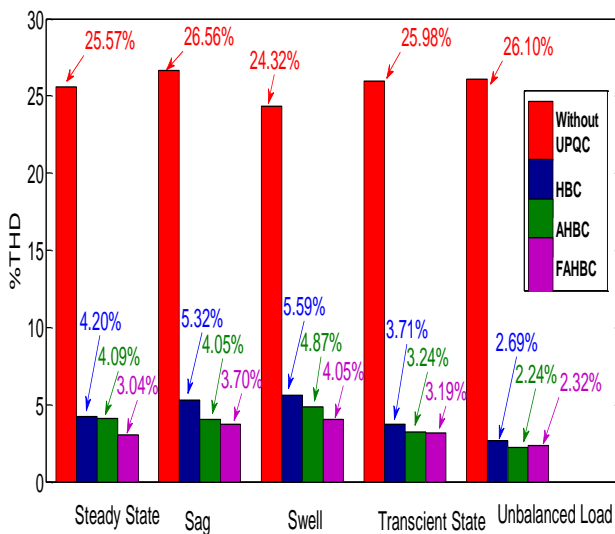
Table 2 show the percentage of total harmonic distortions of source current and load voltage for different conditions with different pulse width modulation techniques. It can be seen from the table 2 that better current harmonic compensation is achieved with fuzzy adaptive hysteresis controller.

**Table 2.** Total Harmonic Distortion Measurement

% Total Harmonic Distortion						
	Measured Parameters	Steady State Condition	During Sag	Swell	Transient load	Unbalanced load
Without UPQC	Is	25.57	26.66	24.32	25.98	26.10
	VL	21.66	29.32	15.69	20.34	20.34
Fixed HCC	Is	4.21	4.74	6.51	4.88	2.60
	VL	3.15	2.94	3.18	2.82	2.88
Adaptive HCC	Is	4.09	4.05	5.73	3.93	2.50
	VL	2.80	2.67	2.68	2.58	2.36
Fuzzy AHCC	Is	3.64	3.87	3.94	3.66	2.20
	VL	2.61	2.71	2.53	2.42	2.21

**Table 3.** Simulation Parameters

Voltage (Vs)	415V (L-L)
Frequency	50Hz
$R_s, L_s$	0.1 $\Omega$ , 0.15mH
$C_f, R_{sw}$	90 $\mu$ f, 1 $\Omega$
$L_{sh}$	10mH
Three Phase Load Diode Bridge Rectifier	Steady State Load: 30 $\Omega$ , 20mH Transient Load: 50 $\Omega$ , 20mH
Single Phase Load Diode Bridge Rectifier	20 $\Omega$ , 1mH
$C_{dc}$	2200 $\mu$ F
$V_{dc}$	700V
Fixed Hysteresis Band	$\pm 0.5$



**Fig. 20:** Bar chart of Source Current Harmonics

## 7. Conclusion

In this paper a fuzzy adaptive hysteresis controller is presented, to generate switching pulses for three phase four wire UPQC to

improve power quality at distribution network. UPQC with proposed fuzzy controller can compensate voltage sag/swell, current and voltage harmonics, and neutral current compensation. The proposed controller with SRF theory has got better tracking performances of compensating current when compared to conventional adaptive hysteresis controller. The voltage and current bands are easily obtained by fuzzy controller to maintain constant switching frequency. The proposed method results are compared with the conventional method. From the results we can conclude that the proposed method has got better compensation capability of current harmonics under different conditions.

## References

- [1] M. Shafiee Khor and M. Machmoum, "Simplified analogical control of a unified power quality conditioner", IEEE Power Electronics Specialist Conference, 2005, Brazil, CD-ROM.
- [2] H. Fujita and H. Akagi, "The unified power quality conditioner: the integration of series-and shunt-active filter", IEEE Trans. on Power Electronics, vol. 13, no. 2, March 1998, pp. 315-322.
- [3] Li.Xun, Zhu. Guorong, Duan. Shanxu and Chen Jian Chen, "Control Scheme for Three-Phase Four-Wire UPQC in a Three-Phase Stationary Frame," in Proc.IEEE/IECON 2007, pp.1732-1736, 2007.
- [4] Zainal Salam, Tan Perng Cheng and Awang Jusoh, " Harmonics Mitigation using Active Power Filter : A Technological Review" Elekrika, Vol.8, No.2, 2006, 17-26.
- [5] S. Buso, L. Malesani and P. Mattavelli, " Comparison of current control Techniques for Active power Filter Applications", IEEE Transactions on Industrial Electronics, Vol.45, no.5, pp.722-729, Oct 1998.
- [6] H. Ezoji, A. Sheikholeslami, M. Tabasi, and M.M. Saeednia, "Simulation of Dynamic Voltage Restorer using hysteresis voltage control", European Journal of Scientific Research (EJSR) 27 (1) (2009) 152-166.
- [7] M. Rajendran and D.Velayutham, "Power quality problem mitigation by unified power quality conditioner: an adaptive hysteresis control technique", Int. J. Power Electronics, Vol. 6, No. 4, 2014.
- [8] Yash Pal, A. Swarup and Bhim Singh, A Comparative Analysis of Three-Phase Four-Wire UPQC Topologies, Proc.IEEE,2010,pp 978-1-4244-7781-4/10,2010@IEEE.
- [9] R. K. Patjoshi and K. K. Mahapatra, "High Performance Unified Power Quality Conditioner using Nonlinear Sliding Mode and New Switching Dynamics Control Strategy," IET Power Electronics Volume 10, Issue 8, 30 June 2017, p. 863 - 874.
- [10] S.Sasitharan and M.K.Mishra, "Constant switching frequency band controller for dynamic voltage restorer," IET Power Electron, Vol.3, 2010, Iss.5, pp.657-667.
- [11] S.V.Manikanthan and T.Padmapriya "Recent Trends In M2m Communications In 4g Networks And Evolution Towards 5g", International Journal of Pure and Applied Mathematics, ISSN NO:1314-3395, Vol-115, Issue -8, Sep 2017.
- [12] T. Padmapriya and V. Saminadan, "Inter-cell Load Balancing technique for multi-class traffic in MIMO-LTE-A Networks", International Journal of Electrical, Electronics and Data Communication (IJEEDC), ISSN: 2320- 2084, vol.3, no.8, pp. 22-26, Aug 2015.