



# GSM based dual power enhanced LED display notice board with motion detector

GowrishankarKasilingam<sup>1</sup>, K.Nithiyananthan<sup>2</sup>, Priyanka Ramesh Mani<sup>3</sup>, Sunil Thomas<sup>4</sup>

<sup>1</sup>Department of ECE, Rajiv Gandhi College of Engg. & Technology, Pondicherry, INDIA

<sup>2</sup>Department of Electrical and Electronics Engineering, Karpagam College of Engineering, Coimbatore, INDIA

<sup>3</sup>AATCO Food Industries, Muscat, OMAN

<sup>4</sup>Department of Electrical and Electronics Engineering, BITS Pilani Dubai Campus, Dubai, UAE

## Abstract

In this paper, a new improved Light Emitting Diode (LED) Display notice board with GSM technology has been created to plug in all the drawbacks in existing framework. The proposed model has an excellent display notice board to display notices or messages at places that require real-time visibility, thereby transferring messages by Short Message Service (SMS) through cellular device. The proposed work in this paper elaborately narrates the procedure to construct a display notice board that has the quality of displaying messages in continuously running mode, and enabling the user to alter the ongoing message using SMS instantaneously. This system also has the feasibility to bind with other devices such as PC or laptop. The best feature of proposed system is the dual system for changing messages. And also utilizes two way power supply such as Renewable energy (Solar Power) and AC power. This feature enables the proposed model to work under any situations which overcomes the drawback in the existing display notice boards. Additionally, a motion detector has been included which turn ON or OFF the system automatically if any motion is not sensed.

## 1. Introduction

A LED display notice board is perfect for displaying information in the form of SMS and the application of this technology can be utilized for any applications. It can be utilized for both outdoor and indoor which makes it a perfect fit for any business or occasion. The LED display notice board is exceptionally productive and taken a toll successful way to spread messages to thousands of individuals, without any individual contact or door-to-door sales. LED is a solid state light source with few appealing properties for display application. In comparison with the glowing light bulb and Field Emission Display (FED), the LED is more vitality efficient which gets to be the defense of selecting LED as the main component. A conventional incandescent light releases heat energy as much as 98 percent instead of light energy while LED light emits very small heat and saves a bunch of energy. A GSM based LED display notice board is a device for showing messages by sending the message in the form of SMS through mobile. GSM is the most well known and accepted standard for mobile phones in the world built up in 1982 and it works in 900 MHz frequency. The GSM benefit is utilized by billions of individuals across the world. GSM makes worldwide roaming very common between mobile phone operators, thus enabling client to use their phones in various parts of the world. GSM special in both signaling and speech clarity, as its channels are digitized. Hence the GSM system is now conferred as a third era (3G) mobile communication system. A motion detector is a device that recognizes the movements of the objects, particularly living beings. A motion detector is regularly incorporated as a component in a system that automatically alerts a client of mobility in a region. A two way power supply display notice board ; i.e., solar and AC power and to change the display either by laptop or SMS through mobile phones is proposed in this

current work. It also incorporates a motion detector which will play the role of a switch in the display notice board.

## 2. Literature Review

Traffic light lamps (cost effective) using LEDs were built up in mid 1990s. However, before this, incandescent or halogen light bulbs based traffic lights were operated. The LED lamps consisted of an arrangement of LED elements in different patterns which noticed from a distance, the LED arrangement appeared as a constant light source not like the incandescent-based lamps there used a single large bulb. A wireless system was designed in the display notice board was not required to reprogramme in order to display a new message. This proposed work was aimed to create a mobile sign board which provides the user to alter the scrolling message using SMS service immediately. The user can change or update the message from a remote area. The previous SMS was omitted from the SIM regularly and provide room for the next or new SMS [1]. The application of embedded system in communication plays major role and the system using LED for such application is presented in [2, 6]. A notable application of LED display using Bluetooth technology which transfers the data from an Android phone [3,4], shows the latest trends in this area of work.

In [5] the authors used a GSM based module to receive the messages and LCD to display them. After, a system which displays messages received from communication devices were proposed by group of researchers [7,]. Here, authentication and attention (AT) commands from a microcontroller controls the system [8], which in turn gave robust and reliable results. In [9] the researcher introduces display design process using both hardware and software based on microcontroller. Consumption of power in LED display notice boards are very less. An LED display system

using radio frequency is reported in [10,11]. The work presented in [12,13] explains a special kind of circular LED display. This display is mechanically scanned and displays the characters in binary format.

### 3. Proposed Led Display Notice Board Model

The system which is proposed in the current work uses dual arrangements for its functioning, i.e., it can use AC inlet as well as solar power. The electricity generated from the solar panel is stored in a battery bank. However for the continuity of uninterrupted power an AC inlet power source is also fed to the system. Another major benefit of this design is the dual capacity

to change messages display (either by GSM technology or by desk bound method). This assures the uninterrupted message display at any given point of time. Another added advantage of this design is that multiple message gets displayed in the LED and also shortens the wait time to read the first message. It helps in commercializing the display system as second message column can be rented to another user for their usage. A motion detector is also embedded in the proposed design and its basic function is to turn off the system when it is not in use. This features reduces the wastage of power and forms a unique advantage in this proposed design. Figure 1 shows the block diagram of the enhanced LED display notice board.

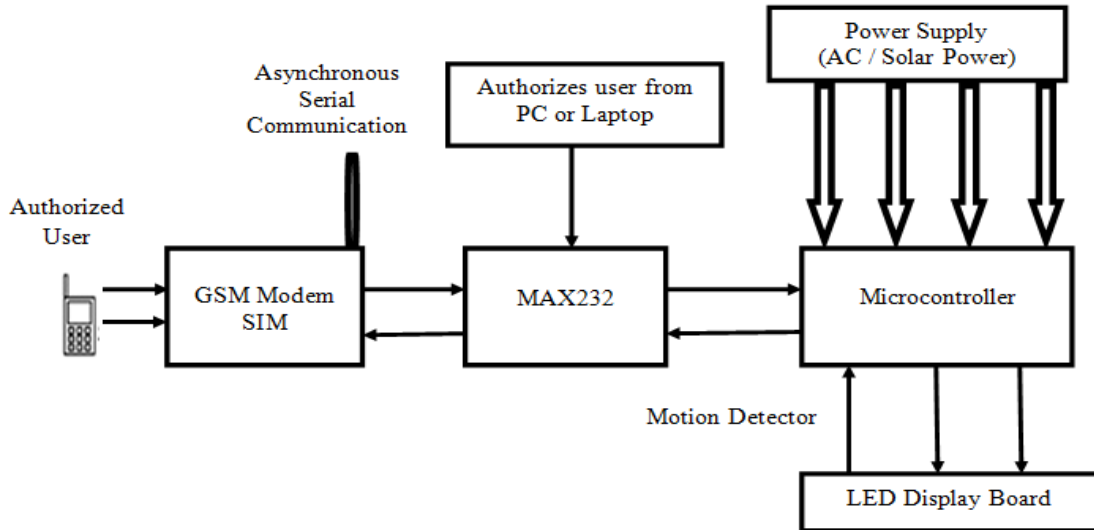

Fig. 1: Block diagram of proposed system

### 4. Process Flow of the GSM Based Display Notice Board

The circuit construction on printed circuit board (PCB) had been designed according to datasheets of microcontroller PIC18F4550,

shift register and LED matrix cube. The detailed block diagram of proposed model is shown in Figure 2.

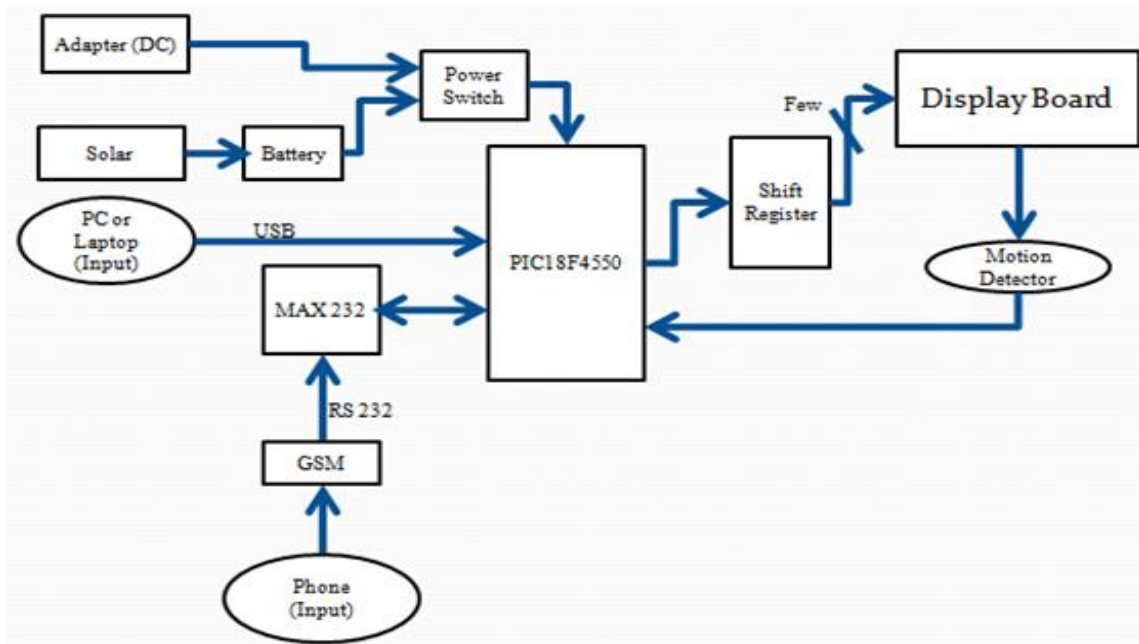

Fig. 2: Detailed Block Diagram of Proposed Model

The construction started from microcontroller IC's master clear switch. This is very important work when it comes to electronic

appliances. The function of the button was to reset the entire system whenever the user presses on it which means the switch is

in high state. The function of master button is, whenever a designed circuit gives problem, hangs or malfunctions, the user can press this button to start back the system. Then a voltage regulator was fixed to give 5V to the microcontroller. After fixing voltage regulator, a 9V power supply was given with help of adaptor to the voltage regulator. Before this procedure was conducted, the 5V from voltage regulator was connected to a 4.7K resistor (pull up resistor) then it was connected to a tap switch and grounded and was connected to pin 1 (MCLR) of microcontroller. After that, LED matrix cube circuit was constructed. This LED cube circuit functions based on shift register (SIPO) which mean the shift register receives inputs from microcontroller's port B and D, then the shift register gives output to the LED cube matrix to display. In this project, the shift register controls the rows and columns of LED cube matrix. In one LED cube matrix, there are 64 LEDs that will be controlled by two shift register. One for row and another one for column of one LED cube matrix. There are two rows and eight columns in this entire project. The serial data input (DS), shift register clock input (SH\_CP) and storage register clock input (ST\_CP) of shift register receives data from programmed PIC for the entire column's shift register. This means every LED cube in that particular row of column uses same DS, SH\_CP and ST\_CP. Then for row DS, SH\_CP, ST\_CP, it receives data from programmed PIC like column but here the second row of shift register receives SH\_CP and ST\_CP from the first row of shift register's SH\_CP and ST\_CP respectively and the (DS) of shift register for every LED cube of row receives data from microcontroller individually. Its goes on similarly until the last column of the first row. Similarly the second row was also designed in the same manner as the first row. Then for the improvisation of the brightness of every single LED matrix cube, the shift register of every row was connected to Darlington driver of every row, which means every output of shift register of that particular row, was connected to Darlington driver of every row as input. Then the output from the Darlington driver was sent to the LED matrix cube. Every LED matrix was designed with one shift register and a Darlington driver for row and one shift register for column. The same design was set for all eight cubes of LED matrix. . Four shift register was used to construct the entire first row. This means, four LED matrix cubes in a row, eight shift registers, and four Darlington drivers were used to build. In every column, one shift register was used and one shift register per LED was used in every row. After second row construction was completed, USB cable connection was done in microcontroller. PIC18F4550 is especially designed for USB. The connection of pin 18 with a capacitor is to prevent USB connection between computer and display system because USB needs sufficient power. Therefore, in order to prevent that, a capacitor was used as nearer as possible to microcontroller. The USB cable has four wires which are 5V (red wire), positive data (green wire), negative data (white wire) and ground (black wire). The positive and negative data wires were connected to pin number 23 (D-) and 24 (D+) of microcontroller. Then the red wire was connected to 5V supply and black wire connected to grounding.[13]

After USB construction was completed, GSM connection was done in microcontroller. PIC18F4550 has UART port to connect with modem like GSM and GPRS. This UART has receiver and transmitter pins in microcontroller. The receiver and transmitter of UART is connected with GSM receiver and transmitter pin. The MAX232 IC was connected between GSM and UART of microcontroller because the signal of GSM carries different voltage and microcontroller cannot support the GSM voltage. So, MAX232 converts the voltage of GSM according to microcontroller and vice versa. The charge pump and external capacitor of MAX232 helps to provide RS232 voltage level output (approximately 7.5V) to 5V supply and vice versa. The MAX232 IC has four important pin to receive and transmit the signal which are pin 11 (T1IN), 9 (R2OUT), 7(T2OUT) and 8(R2IN). The pin 11 and 9 were connected to pin 25 (Tx) and 26 (Rx) of microcontroller respectively. And the pin 8 and 7 were connected to pin number 2 and 3 of RS232 respectively. Besides, the pin

number 5 of RS232 was grounded and pin number 1 and 4 of RS232 were sorted.[14]-[20]

After GSM and USB connections were completed, motion detector connection was done in microcontroller. The microcontroller has three pin which are Vcc (Pin 1), ground (Pin 3) and output of motion detector (Pin 2). The motion detector pin 1 and 3 were connected to 5V and ground, and then, pin number 2 was connected to programmed microcontroller's pin number 40 (RB7) which is port B.

After motion detector connection was completed, power supply for the entire system was done with solar and TNB (AC) power. First, solar connection was done. Solar panel was connected to a charging circuitry and the charging circuitry was connected to a battery and the battery was connected to 2 relay module's first input. On the other side, TNB power adapter was connected to second input pin of 2 relay module. From the 2 relay module, the entire system receives the input. On the 2 relay module, two pins were connected to two transistors and the transistors were connected to microcontroller's pin number 8 (RE0) and 7(RA5) respectively. The function of transistor is to get signal (HIGH or LOW) from microcontroller. When the signal is high (battery voltage above threshold), the 2 relay module switches to solar power and if the signal is low, the 2 relay module switches to TNB power. The reason transistor was used here is because, microcontroller do not have the ability to control 2 relay module straight. Once the battery reaches above threshold voltage, then the charging circuitry sends signal to the microcontroller then the microcontroller controls the 2 relay module through transistor.

The charging circuitry was done by using LM324 IC. LM324 works as comparator between battery (12V) and (5V). There was one relay connected to the output of LM324. In this charging circuitry, voltage divider method was used. 5V was connected to second input of LM324 as reference voltage (threshold) with two 1KΩ resistors in series and 12V battery was connected to first input of LM324 as input voltage with one 10kohm and one 100kohm resistors. If the input voltage is below to the threshold voltage of charging circuitry then the solar starts to charge the battery and sends signal to microcontroller to switch on TNB power supply.

Calculation of Reference Voltage  $V_{ref}$  or  $V_{TH}$  :

$$V_{ref} \text{ or } V_{TH} = 5V \times \left( \frac{R_2}{R_1 + R_2} \right) = 5V \times \left( \frac{1K\Omega}{1K\Omega + 1K\Omega} \right) = 2.5V$$

Calculation of Input Voltage  $V_{in}$  :

$$V_{in} = \text{Battery} \times \left( \frac{R_4}{R_3 + R_4} \right)$$

To calculate the input voltage 3 case studies was considered for  $R_3 = 10\Omega$  &  $R_4 = 100\Omega$

**Table 1:** Calculation of Input voltage for different cases

Case Study	Battery Voltage $V_{battery}$	Input Voltage
If $V_{battery} \gg V_{ref}$	12 V	10.9V
If $V_{battery} \approx V_{ref}$	10 V	9V
If $V_{battery} = V_{ref}$	2.5V	2.27V
If $V_{battery} \ll V_{ref}$	1V	0.9V

C programming language was used to write the coding for PIC18F4550 microcontroller because it is easy to understand, has freedom of using different type of data, and it is an efficient and fast programming. MPLab is software that is provided by Microchip for the development of PIC microcontroller. Through this MPLab, the coding was written to the microcontroller using C language programming. Once the coding for microcontroller was

written, PICKIT 2 was used to burn the program into microcontroller.

#### 4.1 Interface Design

In this work, visual basic interface is for using USB connection through laptop or PC to change the message when the GSM malfunctions. Visual basic is normally to create user interface. Once the interface was designed, the programming for entire interface box was done so that, whenever the user connects USB to the PC, the VB sends message to PIC or microcontroller under any circumstances. The PIC should also be able to read the message that was sent by VB through USB. On the VB message changing form, the past messages or previous messages will be stored in computer to use in future if the desired or current message is same as the previous message. Figure 3 shows the sample of VB display in laptop or PC.

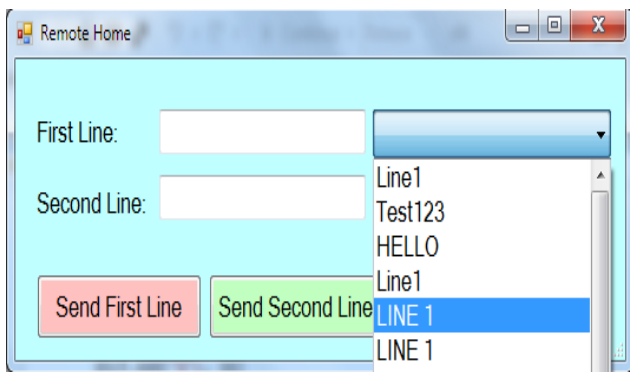

Fig. 3: VB sample display

#### Instruction to use the prototype

How to change message from phone GSM

1. Type password "123456" then space to type message.
2. Type message for first line
3. Type message for second line with "," symbol and without spacing. Example: ,ABCD
4. Press send message.

How to change message from PC

1. Connect to pc or laptop
2. Go to visual basic (VB) folder and choose "PC" file
3. Press play button in VB
4. Enter password to change or display message
5. Choose desired line to display message
6. After typed message in allocated place, press "SEND" button.

How to start the entire system

1. Give both connections to the system. (Solar and TNB)
2. Switch ON the TNB supply.

If the battery is fully charged or above threshold voltage the system automatically switches to battery, or else it will remain in TNB and starts to charge the battery if sunlight is available.

#### 5. Results and Discussion

The design was successful in leading to the new breakthrough in designing the LED display notice board. The flow of the entire system is shown in the figure below. When the user turns on the TNB power supply after connecting with both the power sources (solar and TNB), the system sends signal to 2 relay module to check whether the battery voltage is above threshold voltage or not, if the battery voltage is above threshold voltage, the 2 relay module starts to work with battery otherwise the 2 relay module sticks with TNB to run the system and displays the message that the user sends to the microcontroller through GSM or USB. Once the battery has been fully charged, then the 2 relay module switches to battery automatically. The motion detector works only

after office hours. So, to test this feature, one pin in microcontroller (RC0) was used. When the user gives 5V to this pin, the system works as "after office hour mode", if the user gives 0V then it works as "day time mode". In this project, interrupt function was used whenever message from GSM or USB is received.



Fig. 4: Proposed model with Solar panel

Figure 4 explains the connection of proposed model with solar panel. GSM was used in this project to change the display at display panel. It was programmed in such a way where the user have to enter password whenever the message is decided to be changed. GSM is the primary way of changing message in this system. If GSM malfunctions, then there is an alternative option which is to use USB connection to change the message. The function of USB connection was to connect or communicate with computer whenever the user needs to change message if the GSM is malfunction. The USB connection is an alternative option for the user to change message. There will be a user interface (visual basic) to change the message after connect USB connection on PC or Laptop. The message from the user was sent through USB cable to change message on display notice board. Then, the solar energy is an alternative option for the system to run without failure or reset the PIC when there is no TNB (AC power or no current) power supply. The solar panel was connected to a 12V battery, to store the electricity which generated from solar panel and the battery was fully protected by a charging circuitry. Once the battery had fully charged, the charging circuitry stops the solar panel to produce electrical energy to the battery. This entire system initially starts with TNB power supply but when the battery voltage is more than 11V (threshold voltage) then it will automatically switches to battery which is called as solar power supply with help of door relay module. In this project, the 2 relay module works as a switch between solar power supply and TNB (AC Power) supply. When the battery (connected to solar) voltage is below threshold voltage, then the 2 relay module switches the entire system that works based on TNB power supply. The system starts with TNB power supply and if the battery is above threshold voltage, then the 2 relay module automatically switches the entire system which works based on battery (solar power) power supply. If otherwise, it will remain with TNB power supply, meaning the system will work for 24 hours. The microcontroller was programmed in such a way that at every 2 seconds interval, it will check whether or not the battery voltage is above the threshold voltage. If the battery voltage is below threshold voltage, then the microcontroller will cut-off the battery connection and connects back to TNB power supply and then the charging circuitry starts to

charge the battery. In this project, polycrystalline solar panel was used to give power supply because it is cheap and simple[20]. Function of motion detector in this project is to work at night time as a switch because the system will work normally at

working hours ( 8am-5pm) and after working hours, the system will only work if the motion detector is triggered. The proposed model with battery power supply shown in Figure 5.

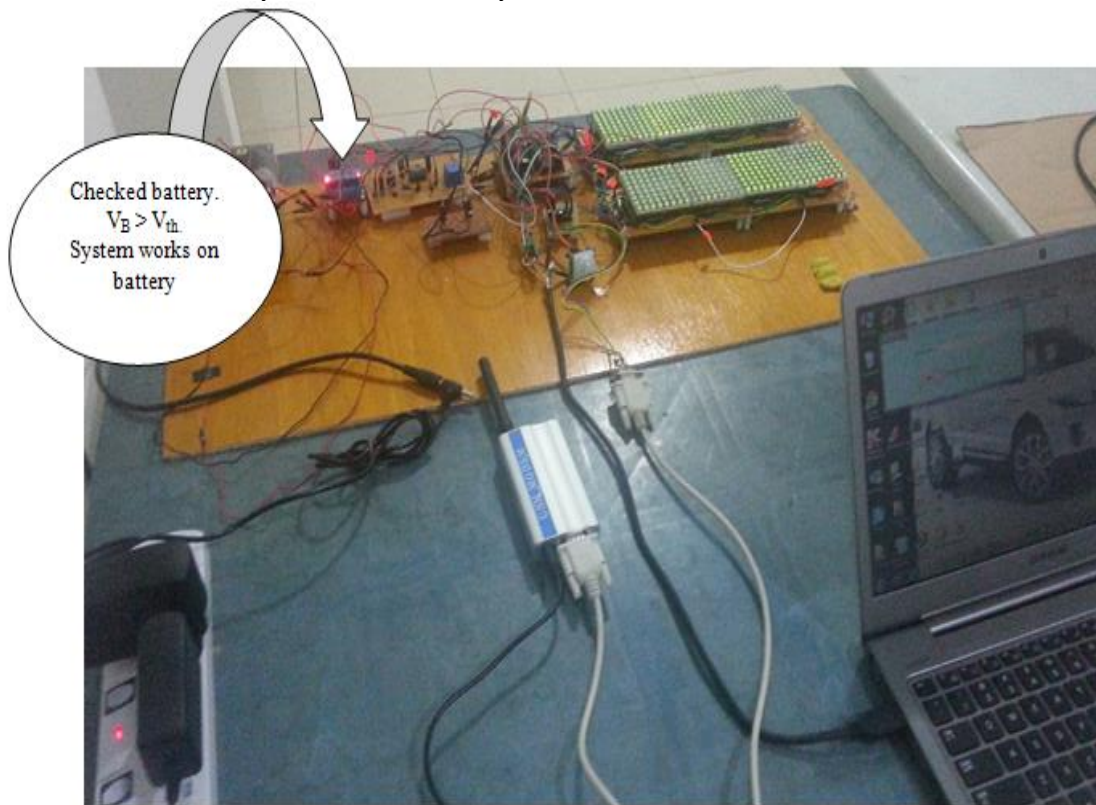

Fig. 5: Proposed model with battery power supply

And Figure 6 to 13 explains the various operations performed on proposed model.

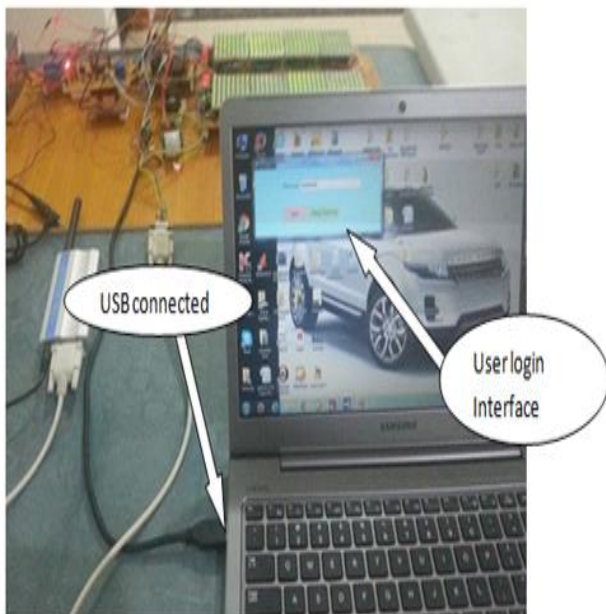

Fig. 6: User interface to change the message through USB

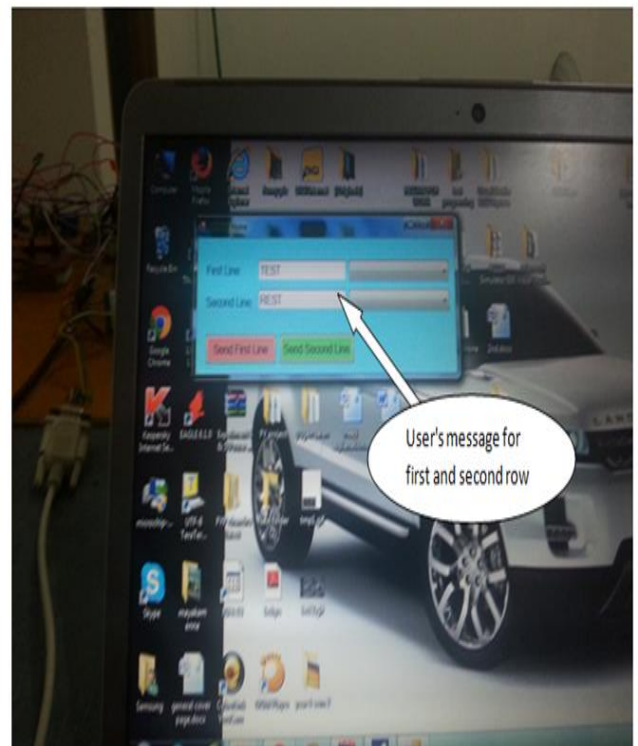

Fig. 7: User messages for first and second row

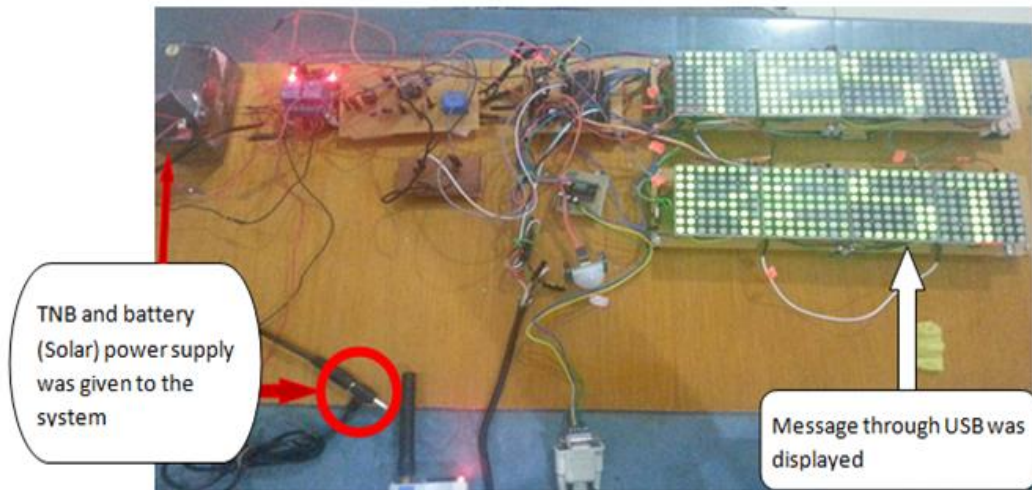

Fig. 8: The message on display panel

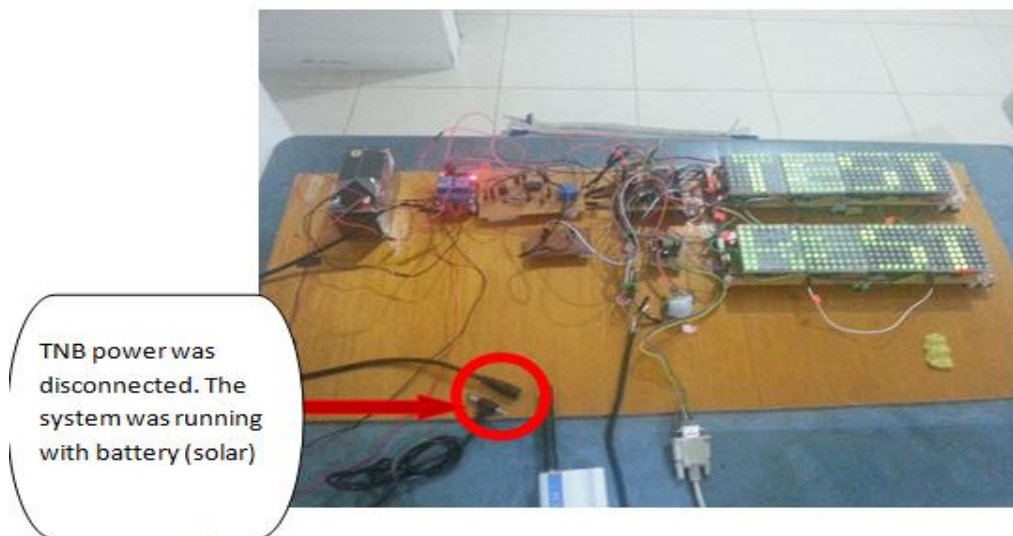

Fig. 9: System is working with battery supply

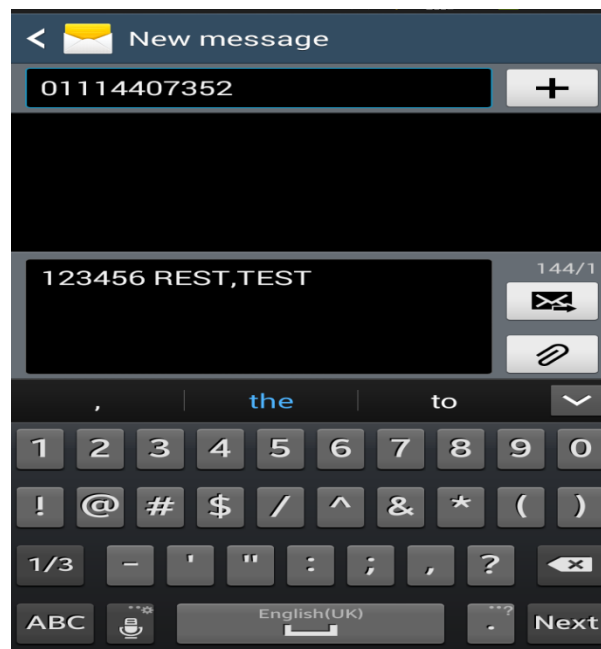

Fig. 10: Message from phone to GSM modem

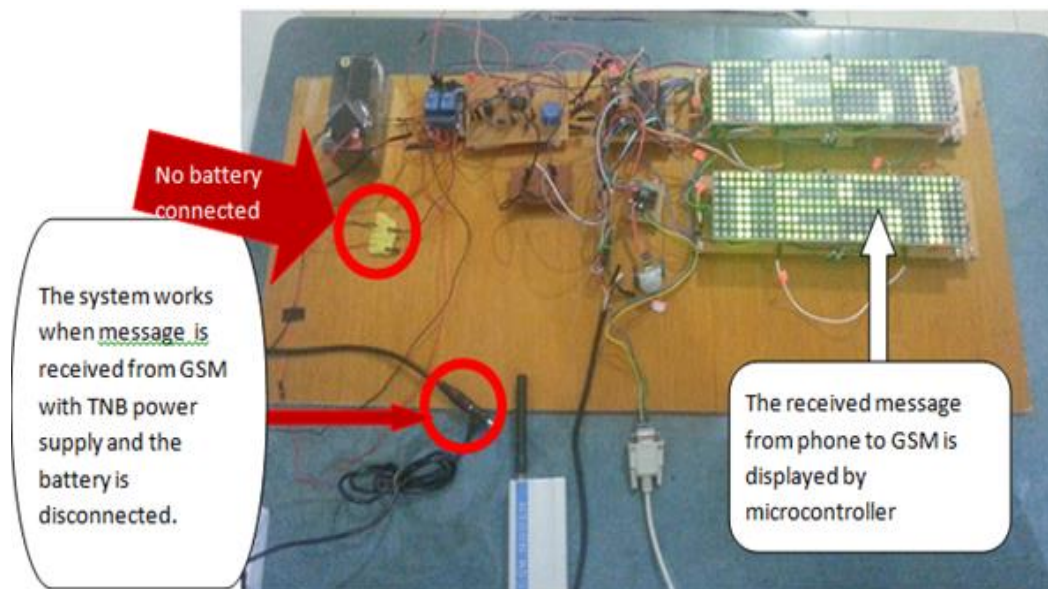

Fig. 11: Message displayed using Electric power supply

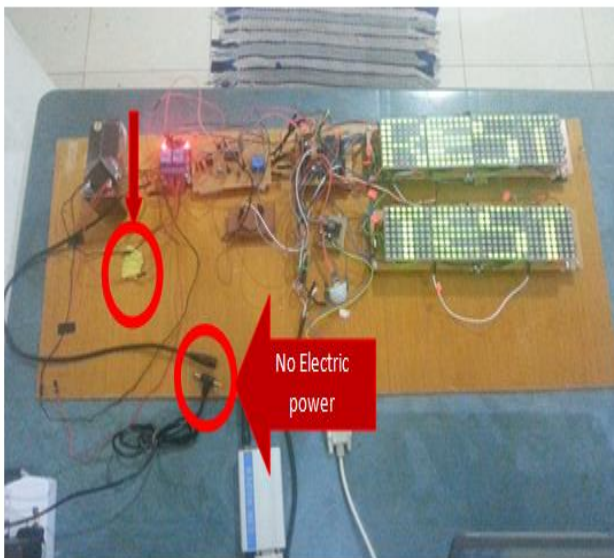

Fig. 12: Message displayed using battery power supply



Fig. 13: Proposed model with motion detector



Fig. 13: Proposed model without motion detector

## 6. Conclusion

By introducing the concept of enhanced LED display notice board, this work had integrated the features of dual power supply, dual option of changing message and inbuilt motion detector in the field of communication. Such collaborative powers and method of changing message had not been developed in a single device, and this work had marked the beginning of the new technology of combining two separate technologies under one roof. Therefore, this new enhanced display system had made the communication more efficient and faster. Certainly this model is able to work under any circumstances with greater efficiency, as it does not need any man power to switch off the system because it had been automated. Besides, in this design, the user is able to display more than one message at a time. From this the user of this display notice board is able to rental out the board as notice board and promotion bill board. In a nutshell, this work describes the new technologies used in the enhancement LED display notice board which is highly efficient than the existing technology and user friendly. As a conclusion, the input from PC or laptop and phone to the micro controller is done through USB and GSM to display the message. Besides, the motion detector has also been incorporated. On the other hand, power supply for the entire system is completed with solar power and AC power. In this project, all the circuits were converted from breadboard to PCB.

## References

- [1] Hardik Gupta, Puja Shukla, Ankita Nagwekar (2013), "GSM based LED scrolling Display notice board", International Journal of Students Research in Technology and Management, Vol.1, pp.278-291.
- [2] Prachee U. Ketkar, Kunal P. Tayade, Akash P. Kulkarni, Rajkishor M. Tugnayat (2013), "GSM Mobile Phone Based LED Scrolling Message Display System", International Journal of Scientific Engineering and Technology, Vol 2, pp.149-155.
- [3] Sooxma Technology, "Android Controlled Scrolling LED Message Display" Hyderabad, India.
- [4] Fauzal Naim Bin Zohedi (2007), "Wireless Electronic Notice Board", Faculty of Electrical & Electronics Engineering, University Malaysia Pahang.
- [5] Pawan Kumar, Vikas Bharadwaj, Kiran Pal, Narayan Singh Rathor, Amit Mishra (2012), "GSM based e-Notice Board: wireless communication", International Journal of Soft Computing and Engineering, Vol. 2, pp.601-605.
- [6] Rahul Kamboj, Preeti Abrol (2013), "Design and Development of GSM based Multiple LED Display notice boards", International Journal of Computer Applications, Vol. 71, pp. 40-46.
- [7] Darshankumar C. Dalwadi, Ninad Trivedi, Amit Kasundra (2011), "Wireless Notice Board Our Real-Time Solution", National Conference on Recent Trends in Engineering & Technology.
- [8] Xiaohong Ni, Zhou Yan, Liu Dan, Yanling Zhou (2013), "The Realization of LED Display System Based on the Embedded", TELKOMNIKA Journal, Vol. 11, pp. 2626-2633.
- [9] Yongxian Song, Yuan Feng Juanli Ma, Xianjin Zhang (2011), "Design of LED Display Control System Based on AT89C52 Single Chip Microcomputer", The Institute of Electronic Engineering Huaihai Institute of Technology Lianyungang, China, Journal of Computers, Vol. 6, pp. 718-724.
- [10] Horanagamabe Wimalasena (2013), "LED Notice Board".
- [11] Apeksha Sarode, Deepali Madhukar Salunke, Akshaydutta Laxmidutta Shukla, Manvi Mukesh Sonawadekar (2012), "Spinning LED Display Using Radio Frequency", International Journal of Computer Science and Informatics, Vol 2.
- [12] Sheikh Rafik Manihar, Mr. Komal Prasad Dewangan, Mr. Ajay Kumar Dansena (2012), "The Design and Construction of a low cost Propeller Led Display", Global Journal of researches in engineering Electrical and electronics engineering, Vol. 12.
- [13] Gowrishankar Kasilingam \*, Mritha Ramalingam and Chandra Sekar A Survey of Light Emitting Diode (LED) Display Board, Indian Journal of Science and Technology, Vol 7(2), 185-188, February 2014.
- [14] Gomathi. V, Dr K. Nithyananthan (2017) "A Single-Stage LED Driver with IGBT for the LDR based Street Lighting System", International Journal of Pure and Applied Mathematics, Asia. V 117, N 7, P 229-240.
- [15] Pratap Nair, Dr K. Nithyananthan, P. Dhinakar (2017) "Design And Development of Variable Frequency Ultrasonic Pest Repeller", Journal of Advanced Research in Dynamical and Control Systems, USA. Vol 12, No 1, Pp. 22-34.
- [16] K. Nithyananthan, G. Sureh Kumaar, M. Srimathi, R. Priyadarshini, J. S. Jebaraj, And T. Somasundharam, (2017), "Development Of Prototype Model For An Automatic Door Closure For Railway Gates," Fronteiras: Journal of Social, Technological And Environmental Science, USA. Vol 6, No2, Pp. 37-46.
- [17] R. Sreega, Dr. K. Nithyananthan, B. Nandhini, (2017) "Design And Development Of Automated Solar Panel Cleaner And Cooler, International Journal Of Electrical And Electronics Engineers, Vol 11, No 1, Pp. 110-115.
- [18] Low Kak Hau, Gowrishankar And Nithyananthan. K, (2015) "Development Of Prototype Model For Wireless Based Control Pick And Place Robotic Vehicle" TELKOMNIKA Indonesian Journal Of Electrical Engineering, Asia, Vol 14 No 1 April 2015, Pp 110-115.
- [19] Nithyananthan. K and S. Nithya, (2015) "Analysis Of Energy Consumption For Digital Serial Interfaces In Low Embedded Systems Processors" International Journal For Electronics And Electrical Engineering, USA, Vol 3, No 1, Pp 1-6 Feb 2015.
- [20] Rahul Kamboj, 'Design and Development of GSM based Multiple LED Display Boards' International Journal of Computer Applications (0975 – 8887) Volume 7 1 No.18, June 2013.
- [21] T. Padmapriya, Ms. N. Dhivya, Ms U. Udhayamathi, "Minimizing Communication Cost In Wireless Sensor Networks To Avoid Packet Retransmission", International Innovative Research Journal of Engineering and Technology, Vol. 2, Special Issue, pp. 38-42.
- [22] S.V. Manikanthan and D. Sugandhi "Interference Alignment Techniques For Mimo Multicell Based On Relay Interference Broadcast Channel " International Journal of Emerging Technology in Computer Science & Electronics (IJETCSE) ISSN: 0976-1353 Volume- 7 , Issue 1 – MARCH 2014.