



# Design and analysis of a wide band rectangular slot loaded planer microstrip antenna

Raj Gaurav Mishra \*, Ranjan Mishra, PiyushKuchhal

School of Engineering, University of Petroleum and Energy Studies, CoES, P.O. Bidholi, Via Prem Nagar, Dehradun-248007, Uttarakhand, India

\*Corresponding author E-mail: <sup>1</sup>rgmishra@ddn.upes.ac.in

## Abstract

This paper presents design and analysis of a rectangular planar microstrip antenna for high bandwidth. The proposed antenna is rectangular in shape with a rectangular slot on the center of patch. The antenna is designed and fabricated with FR4 epoxy substrate. The simulated and experimental results are giving a wide bandwidth of in excess of 4.5 GHz. The measured result also validate the simulate design. A simple analysis is also carried out and impedance is calculated.

**Keywords:** Microstrip Patch Antennas; Genetic Algorithm; GA; Antenna Optimization; High Gain.

## 1. Introduction

Microstrip antenna found its use in many of wireless systems now a day's operating in high frequency [1]. The prime function of any antenna is to transmit and receive electromagnetic signal in wireless environment. An antenna is a significant identity in all wireless application. The radiation from the antenna happens when a sources connected to it is fed with microwave source in high frequency applications.

Antenna is one of the chief components of the wireless system. Low cost and compact antennas are the need of the hour for various wireless applications. The quality of microstrip patch antenna lies in its small weight and size, [2] so it fit well in to device. Microstrip antenna shows a drawback for being narrow bandwidth, but recently many researchers [3-6] introduced new means of increasing its bandwidth.

In the present study, a simple design of a rectangular patch microstrip antenna with one slot and four notches at the corner is presented. This antenna is centrally loaded with a rectangular slot and feed with the microstrip line. The -10 dB bandwidth [7] of the antenna covers 3.8 GHz to 9 GHz of the UWB band. The outline of this paper is as follows. In the section 2, the dimension and geometry of the proposed antenna is presented. The analysis of the simulation and experimental results are done in Section 3. The comparison with the theoretical and measured impedance using transmission line analysis is in section 4, whereas the conclusion is finalized in section 5.

## 2. Antenna Geometry

The geometry of the antenna is planer and rectangular. The dimension of the two sides is found using following sets of equations [8]:

$$\text{The width (W) is: } W = \frac{c}{2f} \times \sqrt{\frac{2}{\epsilon_r + 1}} \quad (1)$$

The effective dielectric constant ( $\epsilon_{\text{eff}}$ ) is:

$$\epsilon_{\text{eff}} = \frac{\epsilon_r + 1}{2} + \frac{\epsilon_r - 1}{2} \sqrt{1 + 12 \frac{h}{W}} \quad (2)$$

The length (L) is:

$$L = \frac{c}{2f} \left( \frac{\epsilon_r + 1}{2} + \frac{\epsilon_r - 1}{2} \sqrt{1 + 12 \frac{h}{W}} \right)^{-\frac{1}{2}} - 2\Delta L \quad (3)$$

The rectangular slot is cut at the middle and it very near to edges. The feed is by microstrip line etched on the same material. In our case it is 50 ohm line. The substrate is FR4 of dielectric constant 4.4. Its main feature for choosing is easy availability, cost effectiveness and low loss tangent which is useful. Substrate height used for fabrication is (h) 1.58 mm and copper as material is used for main radiating element and ground plane for this antenna. The slot length and width are found by slot line analysis [9]. The above equations show that the antenna and its content dimensions are a function of substrate parameter (height and dielectric constant) along with the operating frequency. The operating frequency 'f' is taken to be around 6 GHz. Slight optimization is utilized in the simulation process by HFSS software on these dimensions to get the desired results and also to keep the dimension feasible for the fabrication.

All dimension of the antenna is tabulated in table 1.

**Table 1:** Dimension of Antenna

Parameter	Size
Length of the Antenna	11.5 mm
Width of the Antenna	14 mm
Length of feed line	10.5 mm
Width of feed line	3.6 mm
Length of slot	12 mm
Width of slot	0.75 mm
Length of Ground plane	11.0mm

### 3. Simulation and Experimental Results

Figure 1 shows the planer geometry of the antenna along with the fabricated antenna.

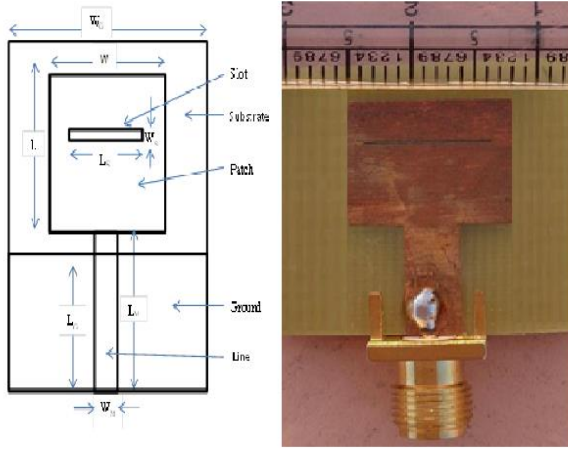

Fig. 1: Theplane geometry and the fabricated microstrip antenna.

The simulation is done on HFSS antenna design software. The best result is obtained with centrally placed slot. It is observed from the HFSS result that the high Wide Band performance has been reached.

The simulated result shows a -10 dB bandwidth ranging from 3.2 to 8.7 GHz. the proper validation of the simulation result is checked by testing on vector network analyzer. The measured values of the return loss are recorded at frequencies range of 3 GHz to 10 GHz and they are plotted along with simulation result. The plot of the simulation and measured result is shown in figure 3.

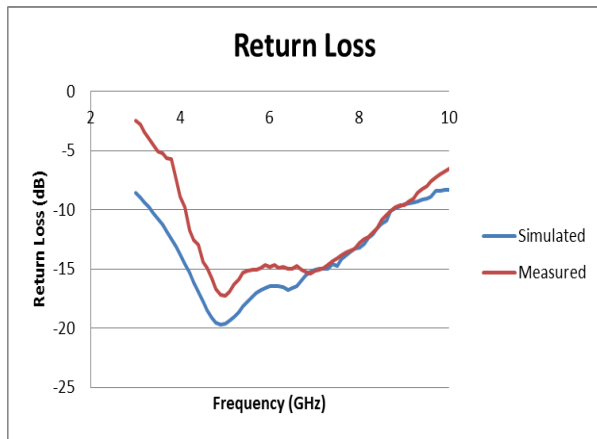

Fig. 2: Return loss of the simulated and measured antenna.

The plot of the two results, as shown in figure 3, is very close to each other. The software simulation result covers the -10dB bandwidth from 3.2 to 8.7 GHz, whereas the measured result is 4 GHz to 8.7 GHz. thus the antenna is showing resonance over a wide frequency of 4.7 GHz. The maximum value of the return loss in simulation is -19.85 dB at 5 GHz and for measured it is also at 5 GHz with a return loss of -17.24 dB. The peak return loss and frequency of the simulated and measured are almost close. The result pattern of the measured is very much same as that of the simulation results. This validates a good result.

Radiation efficiency is plotted as shown in figure 3 and it in between 82% to 94% throughout operating wide band frequency range. Thus gain and directivity of the microstrip designed antenna is close to each other.

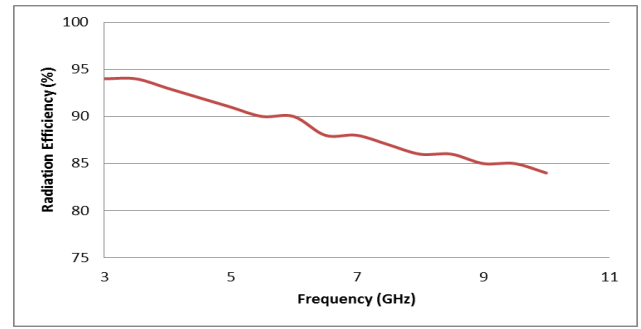

Fig. 3: Radiation efficiency of the antenna.

### 4. Modeling and Impedance Calculation

Transmission line modeling is done for the calculation of impedance. The equivalent circuit is shown in figure 4. The microstrip rectangular antenna is represented as a transmission line that connects two slots of width W and height h.

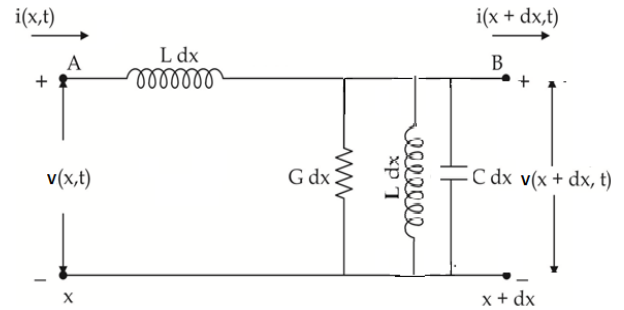

Fig. 4: Equivalent circuits of antenna

Let,  $u(x, t)$  and  $i(x, t)$  be the voltage and current at any point and any time on microstrip antenna. Also let G, C and L represents the conductance, capacitance and inductance of it.

The drop in voltage along the inductor is:  $v = -L \frac{di}{dt}$

The drop in voltage along the capacitor is:  $v = \frac{1}{C} \int idt$

In figure 4, voltage at point B is difference of voltage at point A and AB, and is given as:

$$v(x + dt, t) - v(x, t) = -[Ldx] \frac{di}{dt}$$

Taking as  $dx \rightarrow 0$  and partially differentiating, we have:

$$\frac{\partial v}{\partial x} = L \frac{\partial i}{\partial t}$$

Current at B is the difference of current at A and current flow through conductance and capacitance, and it is therefore given as:

$$\frac{\partial i}{\partial x} = -Gv - I_L - I_C$$

Current passing along the capacitor is:  $I_C = C \frac{\partial v}{\partial t}$

The voltage through the inductor is given as:

$$v = -\frac{1}{G} \frac{\partial i}{\partial x} - \frac{1}{G} I_L - \frac{1}{G} I_C \tag{4}$$

Differentiating this partially with respect to (t), we get:

$$\frac{\partial v}{\partial t} = -\frac{1}{G} \frac{\partial^2 i}{\partial x \partial t} - \frac{1}{G} \frac{\partial I_C}{\partial t} - \frac{1}{G} \frac{\partial I_L}{\partial t} \tag{5}$$

and

$$\frac{\partial v}{\partial t} = -\frac{1}{GL} \frac{\partial^2 v}{\partial x^2} - \frac{G}{C} \frac{\partial^2 v}{\partial t^2} + \frac{v}{LG}$$

or

$$\frac{1}{GL} \frac{\partial^2 v}{\partial x^2} = -\frac{G}{C} \frac{\partial^2 v}{\partial t^2} - \frac{\partial v}{\partial t} + \frac{v}{LG} \tag{6}$$

This is 1-D partial differential equation for micro strip antenna.

The input impedance is:  $Z_{in} = \frac{1}{\frac{1}{R} + j\omega C + \frac{1}{j\omega L}}$

$$\text{So, } Z_{\text{in}} = \frac{R(\omega L)^2}{(\omega L)^2 + R^2(\omega^2 LC - 1)^2} - j \frac{R^2 \omega L(\omega^2 LC - 1)}{(\omega L)^2 + R^2(\omega^2 LC - 1)^2} \quad (7)$$

In the case of microstrip line feed antenna,  $I_1 = I_2 = 0$  and  $L_1 = 0$ . Therefore from equation (1), the value of the antenna input admittance is given as:

$$Y_{\text{in}} = \frac{Y_c^2 + Y_m^2 - Y_m^2 + 2 Y_s Y_c \coth(\gamma L) - 2 Y_m Y_c \cosh(\gamma L)}{Y_s + Y_c \coth(\gamma L)}$$

Taking into account the parasitic effect of the feed line,

$$Y_{\text{in}} = \left(1 - \frac{W_m}{W}\right) Y_s + \frac{Y_c^2 - Y_m^2 + 2 Y_s Y_c \coth(\gamma L) - 2 Y_m Y_c \cosh(\gamma L)}{Y_s + Y_c \coth(\gamma L)}$$

The line parameter is connected with the input admittance. A generalized solution of this equation is given as:

$$Z_{\text{in}} = Z_c \left| \frac{Y_c + j Y_L \tan(\beta L)}{Y_L + j Y_c \tan(\beta L)} \right| \quad (8)$$

For a normalized value of  $\beta L = \pi$ ,  $Z_{\text{in}} = Z_L$ . That means both the line impedance and the input impedance are of the same value at this extreme case of optimization. Solving this and putting the different value of antenna parameter, the normalized value of the characteristic impedance is given as:

$$Z_c = \frac{120\pi / \sqrt{\epsilon_{\text{eff}}}}{W/h + 1.393 + 0.667 \ln(W/h + 1.444)} \quad (9)$$

Putting the values,  $Z_c$  comes to be 46 ohm which is close to the impedance of feed line of 50  $\Omega$ .

## 5. Conclusion

A simple rectangular planer microstrip antenna is designed, fabricated and analyzed. The measured result shows good validation with the simulated one and covers a frequency ranging from 4 to 8.5 GHz. Due to its simplicity and wide bandwidth, the antenna is a good choice for effective wide band applications.

## References

- [1] R. Garg, P. Bhartia, I. Bahl, A. Ittipiboon, Microstrip Antenna Design Handbook, Artech House, 2001.
- [2] Ranjan Mishra, An Overview of Microstrip Antenna, HCTL Open International Journal of Technology Innovations and Research (IJTIR), Volume 21, Issue 2, August 2016.
- [3] G. Z. Rafi and L. Shafai, "Wideband V-Slotted Diamond-Shaped Microstrip Patch Antenna," Electronics Letters, vol. 40, no. 19, pp. 1166–1167, 2004.
- [4] Raj Gaurav Mishra, Ranjan Mishra, Piyush Kuchhal and N. Prasanthi Kumari, "Optimization and analysis of high gain wide-band microstrip patch antenna using genetic algorithm", International Journal of Engineering & Technology, 7 (1.5) (2018) 176-179
- [5] ZhengGuo et al, Bandwidth Enhancement of Monopole UWB Antenna With New Slots and EBG Structures, IEEE antenna and wireless propagation letter, vol 12, 1550-1553, 2013..
- [6] R. Mishra, R. G. Mishra and P. Kuchhal, "Analytical study on the effect of dimension and position of slot for the designing of ultra wide band (UWB) microstrip antenna," IEEE International Conference on Advances in Computing, Communications and Informatics (ICACCI), 2016, pp. 488-493
- [7] Gopikrishna, M., D. D. Krishna, A. R. Chandran, and C. K. Aanandan, "Square monopole antenna for ultra-wide band communication applications," Journal of Electromagnetic Waves and Applications, vol. 21, no. 11, pp 1525–1537, 2007.
- [8] C. Balanis, "Antenna Theory; Analysis and Design", 2nd edition Wiley and Sons, New York, 1982
- [9] K. C. Gupta, R. Garg, I. Bahl and P. Bhartia, "Microstrip Lines and Slotlines," 2<sup>nd</sup> edition, Artech House, 1996.
- [10] T.Padmapriya, Ms. N. Dhivya, Ms U. Udhayamathi, "Minimizing Communication Cost In Wireless Sensor Networks To Avoid Packet Retransmission", International Innovative Research Journal of Engineering and Technology, Vol. 2, Special Issue, pp. 38-42.

- [11] S.V.Manikanthan and T.Padmapriya "Recent Trends In M2m Communications In 4g Networks And Evolution Towards 5g", International Journal of Pure and Applied Mathematics, ISSN NO: 1314-3395, Vol-115, Issue -8, Sep 2017.
- [12] S.V.Manikanthan and K.srividhya "An Android based secure access control using ARM and cloud computing", Published in: Electronics and Communication Systems (ICECS), 2015 2nd International Conference on 26-27 Feb. 2015, Publisher: IEEE, DOI: 10.1109/ECS.2015.7124833.